



DuPage Water Commission

600 E. Butterfield Road, Elmhurst, IL 60126-4642
(630) 834-0100 Fax: (630) 834-0120

AGENDA

DUPAGE WATER COMMISSION

THURSDAY, JANUARY 19, 2017

6:30 P.M.

600 EAST BUTTERFIELD ROAD
ELMHURST, IL 60126

- I. Call to Order and Pledge of Allegiance
 - II. Roll Call
(Majority of the Commissioners then in Office—minimum 7)
 - III. Presentation of Plaque

Richard Furstenau, Municipal Representative District 5
 - IV. Administering Official Oath
 - A. David Russo, County Representative District 6
 - B. Joseph Broda, Municipal Representative District 2
 - C. James Healy, County Representative District 5
 - V. Public Comments (limited to 3 minutes per person)
 - VI. Approval of Minutes
(Concurrence of a Majority of those Commissioners Present, provided there is a quorum—minimum 4)
- RECOMMENDED MOTION: To approve the Minutes of the December 15, 2016 Regular Meeting of the DuPage Water Commission (Voice Vote).**
- VII. Treasurer's Report – December 2016
(Concurrence of a Majority of those Commissioners Present, provided there is a quorum—minimum 4)

RECOMMENDED MOTION: To accept the December 2016 Treasurer's Report (Voice Vote).

All visitors must present a valid driver's license or other government-issued photo identification, sign in at the reception area and wear a visitor badge while at the DuPage Pumping Station.

VIII. Committee Reports

A. Finance Committee

1. Report of 1/19/17 Finance Committee
2. Request for Board Action –Authorizing the Transfer of Funds from the Sales Tax Account to the Long Term Water Capital Reserve Account **(Approximately \$2.1 Million)**

(Concurrence of a Majority of the Appointed Commissioners-7)

RECOMMENDED MOTION: To Authorize the Transfer of Funds from the Sales Tax Account to the Long Term Water Capital Reserve Account (Approximately \$2.1 Million) (Roll Call).

3. Actions on Other Items Listed on 1/19/17 Finance Committee Agenda

B. Administration Committee

1. Report of 1/19/17 Administration Committee
2. Ordinance No. O-1-17: An Ordinance Approving and Authorizing the Execution of a Water Purchase and Sale Contract Between the DuPage Water Commission and the Village of Bartlett for the Village of Bartlett Unit System

(Affirmative Majority of the Appointed Commissioners, containing the votes of at least 1/3 of the County Appointed Commissioners and 40% of the Municipal Appointed Commissioners—3 County + 3 Muni+1=7)

3. Ordinance No. O-2-17: An Ordinance Approving and Authorizing the Execution of an Intergovernmental Agreement Between the DuPage Water Commission and the Village of Bartlett Concerning A Loan for Capital Cost Recovery Charge to the Village of Bartlett

(Affirmative Majority of the Appointed Commissioners, containing the votes of at least 1/3 of the County Appointed Commissioners and 40% of the Municipal Appointed Commissioners—3 County + 3 Muni+1=7)

4. Ordinance No. O-3-17: An Ordinance Approving and Authorizing the Execution of An Intergovernmental Agreement Between the DuPage Water Commission and the Village of Bartlett Concerning the Loan for Connection Facilities to Implement Water Service to the Village of Bartlett

(Affirmative Majority of the Appointed Commissioners, containing the votes of at least 1/3 of the County Appointed Commissioners and 40% of the Municipal Appointed Commissioners—3 County + 3 Muni+1=7)

RECOMMENDED MOTION: To adopt item numbers 2 through 4 under the Administration Report section of the Agenda in a single group pursuant to the Omnibus Vote Procedures (Roll Call).

5. Actions on Other Items Listed on 1/19/17 Administration Committee Agenda

C. Engineering & Construction Committee

1. Report of 1/19/17 Engineering & Construction Committee
2. Resolution No. R-1-17: A Resolution Authorizing the General Manager to execute a three (3) year Janitorial Services Contract with Eco Clean Maintenance Inc. for Periodic Janitorial Services at the DuPage Pumping Station. **(estimated at \$75,182.40)**

(Concurrence of a Majority of the Appointed Commissioners - 7)

3. Resolution No. R-2-17: A Resolution Approving and Ratifying Certain Contract Change Orders for Masonry Rehabilitation and Window Replacement Work at the DuPage Pumping Station at the January 19, 2017 DuPage Water Commission Meeting. **(Mertes Contracting Corporation increase in contract price of \$34,470.00 for a total contract price of \$320,915.00)**

(Affirmative Majority of the Appointed Commissioners, containing the votes of at least 1/3 of the County Appointed Commissioners and 40% of the Municipal Appointed Commissioners—3 County + 3 Muni+1=7)

4. Resolution No. R-3-17: A Resolution Approving and Ratifying Certain Change Orders for the Rehabilitation of Coating Systems and Fall Protection Systems for Tank Site No. 1 and No. 4 East (Contract SS-7/16) at the January 19, 2017, DuPage Water Commission Meeting. **(decrease the net contract price by \$1,580.00 for a total contract price of \$2,906,000.00)**

(Affirmative Majority of the Appointed Commissioners, containing the votes of at least 1/3 of the County Appointed Commissioners and 40% of the Municipal Appointed Commissioners—3 County + 3 Muni+1=7)

5. Request For Board Action - To Suspend the Purchasing Procedures of the Commission's By-Laws and authorize the General Manager to execute a 3-year term contract with AT&T for telephone services. **(AT&T in the amount of \$27,099.00)**

(TO SUSPEND PURCHASING PROCEDURES: 2/3 Majority of those Commissioners Present, provided there is a quorum)

(Concurrence of a Majority of the Appointed Commissioners - 7)

RECOMMENDED MOTION: To adopt item numbers 2 through 5 under the Engineering & Construction Report section of the Agenda in a single group pursuant to the Omnibus Vote Procedures (Roll Call).

6. Actions on Other Items Listed on 1/19/17 Engineering & Construction Committee Agenda

IX. Accounts Payable

(Affirmative Majority of the Appointed Commissioners, containing the votes of at least 1/3 of the County Appointed Commissioners and 40% of the Municipal Appointed Commissioners—3 County + 3 Muni+1=7)

RECOMMENDED MOTION: To approve the Accounts Payable in the amount of \$8,268,216.34 subject to submission of all contractually required documentation, for invoices that have been received (Roll Call).

RECOMMENDED MOTION: To approve the Accounts Payable in the amount of \$695,330.00 subject to submission of all contractually required documentation, for invoices that have not yet been received but have been estimated (Roll Call).

X. Chairman's Report

XI. Omnibus Vote Requiring Majority Vote

XII. Omnibus Vote Requiring Super-Majority or Special Majority Vote

XIII. Old Business

XIV. New Business

XV. Executive Session

(Concurrence of a Majority of those Commissioners Present, provided there is a quorum—minimum 4)

RECOMMENDED MOTION: To go into Executive Session to discuss security procedures pursuant to 5 ILCS 120/2(c)(8), to discuss matters related to personnel pursuant to 5 ILCS 120/2(c)(1) and (2), to discuss acquisition of real estate pursuant to 5 ILCS 120/2(c)(5), to discuss pending, probable, or imminent litigation pursuant to 5 ILCS 120/2(c)(11), and/or to discuss minutes of closed meetings pursuant to 5 ILCS 120/2(c)(21) (Roll Call).

RECOMMENDED MOTION: To come out of Executive Session (Voice Vote).

XVI. Adjournment

(Concurrence of a Majority of those Commissioners Present, provided there is a quorum—minimum 4)

**MINUTES OF A MEETING OF THE
DuPAGE WATER COMMISSION
HELD ON THURSDAY, DECEMBER 15, 2016
600 E. BUTTERFIELD ROAD
ELMHURST, ILLINOIS**

The meeting was called to order by Chairman Zay at 6:37 P.M.

Commissioners in attendance: J. Broda, L. Crawford, R. Furstenau, D. Novotny, J. Pruyne, D. Russo, F. Saverino, M. Scheck, P. Suess, and J. Zay

Commissioners Absent: J. Fennell, R. Gans, and D. Loftus

Also in attendance: Treasurer W. Fates, J. Spatz, C. Johnson, C. Peterson, T. McGhee, F. Frelka, J. Schori, M. Weed, and P. Luetkehans representing Gorski & Good

PRESENTATION OF PLAQUES

Chairman Zay presented Commissioner Crawford with a Plaque thanking her for her service, hard work and dedication and wished her all the best. Commissioner Crawford thanked Chairman Zay for the opportunity noting it had been an honor.

PUBLIC COMMENT

None

APPROVAL OF MINUTES

Commissioner Broda moved to approve the Minutes of the November 17, 2016 Regular Meeting of the DuPage Water Commission. Seconded by Commissioner Furstenau and unanimously approved by a Voice Vote.

All voted aye. Motion carried.

TREASURER'S REPORT

Treasurer Fates presented the November 2016 Treasurer's Report consisting of 13 pages, noting that pages 1, 2 and 3 contained a brief summary of the report.

Treasurer Fates pointed out the \$156.4 million of cash and investments on page 4, which reflected an increase of about \$0.9 million from the previous month. Treasurer Fates also pointed out the schedule of investments on pages 5 through 11 totaling \$141.1 million and the market yield on the total portfolio showed 1.08% basis points which remained the same from the prior month. On page 12, the statement of cash flows showed an increase in cash and investments by about \$20.1 million and operating activities increased cash by approximately \$8.5 million, and roughly \$12.4 million of sales tax was received. On page 13, the monthly cash/operating report showed that the Commission had met or exceeded all of its reserve requirements.

Minutes of the 12/15/16 Commission Meeting

Commissioner Russo moved to accept the November 2016 Treasurer's Report.
Seconded by Commissioner Furstenau and unanimously approved by a Voice Vote.

All voted aye. Motion carried.

COMMITTEE REPORTS

Finance Committee – Reported by Commissioner Suess

Commissioner Suess reported that the Finance Committee had reviewed all items listed on the Finance Committee Agenda. Although there were no action items for consideration, Commissioner Suess noted that Illinois American Water had finished paying off the remaining balance on their subsequent customer cost (approximately \$2.6 million) and that the General Manager would be making a recommendation as to how to distribute those funds within the various reserve accounts.

Administration Committee – Reported by Commissioner Crawford

Commissioner Crawford reported that the Administration Committee had reviewed and recommended for approval all action items listed on the Administration Committee Agenda. After providing a brief summary, Commissioner Crawford moved to authorize the General Manager to enter into a Consulting Agreement with John J. Millner and Associates, Inc., subject to negotiation of acceptable terms, in an amount not to exceed \$24,000.00. Seconded Commissioner Saverino.

General Manager Spatz noted that going forward Mr. Millner would be providing monthly status reports regarding any legislation pertaining to the Commission. With no further discussion, the motion was unanimously approved by a Roll Call Vote.

Ayes: J. Broda, L. Crawford, R. Furstenau, D. Novotny, J. Pruyn, D. Russo, F. Saverino, M. Scheck, P. Suess, and J. Zay

Nays: None

Absent: J. Fennell, R. Gans, and D. Loftus

Engineering & Construction Committee – Reported by Commissioner Furstenau

Commissioner Furstenau reported that the Engineering & Construction Committee reviewed and recommended for approval all action items listed on the Engineering & Construction Committee Agenda. After providing a brief summary, Commissioner Furstenau moved to suspend the purchasing procedures of the Commission's By-Laws and authorize the General Manager to approve Requisition No. 44031 (Infor Enterprise Asset Management System Annual Software Maintenance Agreement – \$42,911.01). Seconded by Commissioner Saverino and unanimously approved by a Roll Call Vote.

Minutes of the 12/15/16 Commission Meeting

Ayes: J. Broda, L. Crawford, R. Furstenau, D. Novotny, J. Pruyn, D. Russo, F. Saverino, M. Scheck, P. Suess, and J. Zay

Nays: None

Absent: J. Fennell, R. Gans, and D. Loftus

ACCOUNTS PAYABLE

Commissioner Broda moved to approve the Accounts Payable in the amount of \$7,675,589.44 subject to submission of all contractually required documentation, for invoices that have been received and the Accounts Payable in the amount of \$2,553,410.00 subject to submission of all contractually required documentation, for invoices that have not yet been received but have been estimated. Seconded by Commissioner Russo and unanimously approved by a Roll Call Vote.

Ayes: J. Broda, L. Crawford, R. Furstenau, D. Novotny, J. Pruyn, D. Russo, F. Saverino, M. Scheck, P. Suess, and J. Zay

Nays: None

Absent: J. Fennell, R. Gans, and D. Loftus

CHAIRMAN'S REPORT

Chairman Zay reported that the Commission had been selected by the Village of Bartlett to supply them with Lake Michigan water and that staff was currently working with representatives from Bartlett along with the Commission's attorney to develop a draft agreement. Chairman Zay informed that the process was moving very quickly as Bartlett's Village Manager would be retiring soon and would like everything finalized and signed by the end of January 2017.

Chairman Zay and General Manager Spatz reassured the Board that they would have a chance, at the January 2017 Board meeting, to review the draft agreement before it was submitted to the Village.

Commissioner Suess asked when the Village anticipates receiving the Commission's water service and General Manager Spatz replied that water service should be in by May of 2019.

After Chairman Zay noted the benefits of expanding the Commission's customer base, he wished everyone a Happy and Healthy Holiday and thanked the Commissioners and staff for their continued hard work and dedication.

OMNIBUS VOTE REQUIRING MAJORITY VOTE

None

Minutes of the 12/15/16 Commission Meeting

OMNIBUS VOTE REQUIRING SUPER-MAJORITY OR SPECIAL MAJORITY VOTE

None

OLD BUSINESS

None

NEW BUSINESS

General Manager Spatz referred to the Commission's Annual Holiday Gift Giving Program and thanked everyone for their participation noting that with all the generous donations the Commission was able to help out three families this year.

EXECUTIVE SESSION

None

Commissioner Russo moved to adjourn the meeting at 7:00 P.M. Seconded by Commissioner Broda and unanimously approved by a Voice Vote.

All voted aye. Motion carried.

Board/Minutes/Commission/2016/Rcm161215docx

DUPAGE WATER COMMISSION INTEROFFICE MEMORANDUM

TO: Chairman and Commissioners
FROM: Bill Fates, Treasurer
DATE: January 10, 2017
SUBJECT: TREASURER'S REPORT – DECEMBER 31, 2016

I am pleased to report that I have reviewed and approved all journal entries and bank reconciliations for the month of December. I have also reviewed the monthly financial statements and budget status reports, and found them to be in order.

Summary of Cash & Investments (Page 4)

1. Cash and investments totaled \$159.8 million at December 31st, an increase of \$3.4 million over the previous month.
2. The balance in the BMO Harris checking account was \$16.0 million at December 31st, an increase of approximately \$0.7 million compared to the \$15.3 million reported last month.
3. The BMO Harris money market accounts had \$15.0 million at month-end, unchanged from the preceding month.
4. During the month of December, the IIIT money market accounts increased by approximately \$43,000 from the prior month.
5. In December, our holdings of Commercial Paper and U.S. Agency investments increased by approximately \$1.9 million and \$0.7 million, respectively.
6. The current holdings of cash and investments are in compliance with the approved investment policy.
7. During the first eight months of the year, the Commission's cash and investments increased a total of \$23.5 million.
 - The Operating & Maintenance Account increased by \$8.9 million, for an ending balance of \$31.0 million.
 - The General Account increased by \$3.7 million, for an ending balance of \$19.7 million.
 - The Sales Tax Account remained relatively unchanged at \$2.1 million.
 - The Capital Reserve Fund increased \$191,228 for a balance of \$29.7 million.
 - The Operating Reserve Account increased \$10.6 million for a balance of \$67.0 million.

- The Long-Term Capital Reserve Account increased by \$128,398 for a balance of \$10.2 million.

The following table presents a summary of the changes in cash position by account.

Cash and Investments by Account

Account	Balance 4/30/2016	Balance 12/31/2016	Increase (Decrease)
Operations & Maintenance	\$22,137,284	\$31,036,938	\$8,899,654
General Account	15,977,169	19,661,276	3,684,107
Sales Tax	2,131,597	2,133,332	1,735
Operating Reserve	56,389,449	66,984,325	10,594,876
Capital Reserve	29,541,577	29,732,805	191,228
Long-Term Cap. Reserve	10,113,085	10,241,483	128,398
Total Cash & Investments	\$136,290,161	\$159,790,159	\$23,499,998

Schedule of Investments (Pages 5-11)

1. The average yield to maturity on the Commission's investments was 1.13%, an increase from the prior month average yield to maturity of 1.08%.
2. The portfolio is showing estimated unrealized losses of \$817,000 at December 31, 2016, compared to \$537,500 in unrealized gains at April 31, 2016.
3. The amortized cost of our investments was \$143.8 million at December 31st, an increase of approximately \$2.7 million from the previous month.

Statement of Cash Flows (Page 12)

1. The statement of cash flows shows a breakdown of the \$23.5 million increase in cash and investments since the beginning of the fiscal year.
2. Operating activities increased cash by \$13.5 million.
3. \$12.4 million of sales tax revenue was received.
4. Capital Assets purchased totaled \$3.3 million year-to-date.
5. Cash flow from investment activity generated \$1.1 million.

Reserve Analysis (Page 13)

1. The reserve analysis report shows the commission has met or exceeded all reserve targets at December 31st.
2. The Operating and Maintenance Account was nearly \$22.0 million over its target balance of \$9.1 million.
3. The Operating Reserve account is \$27.4 million over its minimum target of \$39.6 million due to additional transfers made during the current and prior year to increase the balance beyond its minimum per the Board.

Respectfully submitted,

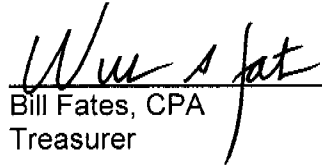
A handwritten signature in cursive script, appearing to read "Bill Fates", is written over a horizontal line. The signature is written in black ink and is positioned above the printed name and title.

Bill Fates, CPA
Treasurer

DU PAGE WATER COMMISSION
 TREASURER'S REPORT
 SUMMARY OF CASH AND INVESTMENTS
 December 31, 2016

FUNDS CONSIST OF:	December 31, 2016	November 30, 2016	INCR. - (DECR.)
PETTY CASH	1,200.00	1,200.00	0.00
CASH AT HARRIS BANK	16,036,252.72	15,346,936.83	689,315.89
TOTAL CASH	16,037,452.72	15,348,136.83	689,315.89
IIIT MONEY MARKET FUNDS	1,243,803.62	1,200,925.77	42,877.85
BMO HARRIS MONEY MARKET FUNDS	14,999,485.36	14,991,747.82	7,737.54
U. S. TREASURY INVESTMENTS	32,941,509.51	32,761,360.37	180,149.14
U. S. AGENCY INVESTMENTS	60,803,674.02	60,107,366.67	696,307.35
MUNICIPAL BONDS	6,403,633.51	6,404,000.36	(366.85)
COMMERCIAL PAPER	16,736,111.37	14,877,803.48	1,858,307.89
ASSET BACKED SEC/COLLATERALIZED MORTGAGE OBLIG CERTIFICATES OF DEPOSIT	6,904,489.04 3,720,000.00	7,018,219.41 3,720,000.00	(113,730.37) 0.00
TOTAL INVESTMENTS	143,752,706.43	141,081,423.88	2,671,282.55
TOTAL CASH AND INVESTMENTS	159,790,159.15	156,429,560.71	3,360,598.44
	December 31, 2016	November 30, 2016	% CHANGE
IIIT MONEY MARKET FUNDS	0.9%	1.0%	3.6%
BMO HARRIS MONEY MARKET FUNDS	10.4%	10.6%	0.1%
U. S. TREASURY INVESTMENTS	22.9%	23.2%	0.5%
U. S. AGENCY INVESTMENTS	42.3%	42.6%	1.2%
MUNICIPAL BONDS	4.5%	4.5%	0.0%
COMMERCIAL PAPER	11.6%	10.5%	12.5%
ASSET BACKED SEC/COLLATERALIZED MORTGAGE OBLIG CERTIFICATES OF DEPOSIT	4.8% 2.6%	5.0% 2.6%	-1.6% 0.0%
TOTAL INVESTMENTS	100.0%	100.0%	1.9%

Note 1 - Investments are carried at amortized cost.

DU PAGE WATER COMMISSION
INVESTMENTS
(Unaudited)
December 31, 2016

FUND SOURCE	COUPON RATE	PURCHASE DATE	MATURITY DATE		YIELD TO MATURITY (COST)	PAR VALUE	AMORTIZED COST	AMORTIZED DISCOUNT (PREMIUM)	PURCHASE PRICE	ACCRUED INTEREST 12/31/16
Water Fund Oper. & Maint. Acct. (01-121103)										
BMO Harris - Money Market	0.620%	12/31/16	01/01/17	1	0.620%	\$ 14,999,485.36	\$ 14,999,485.36	\$ -	\$ 14,999,485.36	-
Water Fund General Account (01-121700)										
IIIT - Money Market	0.660%	12/31/16	01/01/17	1	0.660%	999,063.33	999,063.33	-	999,063.33	-
Cooperatieve Rabobank UA CP	0.000%	10/03/16	01/20/17	20	0.900%	1,000,000.00	999,525.00	2,225.00	997,300.00	-
American Honda Finance CP	0.000%	11/14/16	01/27/17	27	0.660%	2,000,000.00	1,999,046.66	1,759.99	1,997,286.67	-
Toyota Motor Credit Corp CP	0.000%	10/03/16	03/03/17	62	1.000%	1,500,000.00	1,497,458.34	3,708.34	1,493,750.00	-
JP Morgan Securities LLC CP	0.000%	10/04/16	04/04/17	94	1.010%	1,500,000.00	1,496,125.01	3,708.34	1,492,416.67	-
BNP Paribas NY Branch CP	0.000%	12/08/16	06/06/17	157	1.170%	750,000.00	746,230.00	580.00	745,650.00	-
BNP Paribas NY Branch CP	0.000%	12/13/16	06/06/17	157	1.160%	1,250,000.00	1,243,770.83	758.68	1,243,012.15	-
Credit Agricole CIB NY CP	0.000%	12/07/16	06/07/17	158	1.150%	2,000,000.00	1,990,056.66	1,583.33	1,988,473.33	-
Bank Tokyo-MIT UFJ NY CP	0.000%	12/08/16	06/08/17	159	1.280%	2,000,000.00	1,988,852.22	1,693.33	1,987,158.89	-
Bank Tokyo-MIT UFJ NY CP	0.000%	12/19/16	06/19/17	170	1.300%	1,500,000.00	1,490,916.24	698.74	1,490,217.50	-
Toyota Motor Credit Corp CP	0.000%	12/19/16	07/17/17	198	1.200%	1,500,000.00	1,490,232.08	644.58	1,489,587.50	-
CD-Cornerstone Bank, NE	0.000%	10/28/16	02/01/17	32	0.700%	248,000.00	248,000.00	-	248,000.00	309.15
CD-United Security Bank, CA	0.000%	11/16/16	05/15/17	135	0.950%	248,000.00	248,000.00	-	248,000.00	296.92
CD-Quontic Bank, NY	0.000%	11/16/16	05/15/17	135	0.850%	248,000.00	248,000.00	-	248,000.00	265.67
CD-Cfg Community Bank, MD	0.000%	10/31/16	05/31/17	151	0.800%	248,000.00	248,000.00	-	248,000.00	337.01
CD-Patriot Bank, OK	0.000%	10/31/16	05/31/17	151	0.800%	248,000.00	248,000.00	-	248,000.00	337.01
CD-Enerbank USA, UT	0.000%	10/31/16	05/31/17	151	0.700%	248,000.00	248,000.00	-	248,000.00	294.88
CD-Bank of the Ozarks, AR	0.000%	10/31/16	05/31/17	151	0.870%	248,000.00	248,000.00	-	248,000.00	366.50
CD-First Commons Bank, MA	0.000%	10/31/16	05/31/17	151	0.800%	248,000.00	248,000.00	-	248,000.00	337.01
CD-BofI Federal Bank, CA	0.000%	10/31/16	05/31/17	151	0.750%	248,000.00	248,000.00	-	248,000.00	315.95
CD-Usamerbank, FL	0.000%	10/31/16	05/31/17	151	0.740%	248,000.00	248,000.00	-	248,000.00	311.73
CD-Financial Federal Savings Bank, TN	0.000%	10/31/16	05/31/17	151	0.750%	248,000.00	248,000.00	-	248,000.00	315.95
CD-Landmark Community Bank, TN	0.000%	10/31/16	05/31/17	151	0.800%	248,000.00	248,000.00	-	248,000.00	337.01
CD-Bank of China, NY	0.000%	10/31/16	05/31/17	151	0.750%	248,000.00	248,000.00	-	248,000.00	315.95
CD-Prudential Savings Bank, PA	0.000%	10/31/16	05/31/17	151	0.700%	248,000.00	248,000.00	-	248,000.00	294.88
CD-Bank Leumi Usa, NY	0.000%	10/31/16	06/29/17	180	0.850%	248,000.00	248,000.00	-	248,000.00	358.07
Weighted Avg Maturity			113		0.995%	\$ 19,719,063.33	\$ 19,661,276.37	\$ 17,360.33	\$ 19,643,916.04	\$ 4,793.69

DU PAGE WATER COMMISSION
 INVESTMENTS
 (Unaudited)
 December 31, 2016

FUND SOURCE	COUPON RATE	PURCHASE DATE	MATURITY DATE		YIELD TO MATURITY (COST)	PAR VALUE	AMORTIZED COST	AMORTIZED DISCOUNT (PREMIUM)	PURCHASE PRICE	ACCRUED INTEREST 12/31/16
Sales Tax Funds (01-123000)										
IIIT - Money Market	0.660%	12/31/16	01/01/17	1	0.660%	516.22	516.22	-	516.22	-
FNMA Notes	1.000%	10/19/16	08/28/19	970	1.040%	2,135,000.00	2,132,816.02	164.52	2,132,651.50	5,278.19
	Weighted Avg Maturity		970		1.040%	\$ 2,135,516.22	\$ 2,133,332.24	\$ 164.52	\$ 2,133,167.72	\$ 5,278.19

DU PAGE WATER COMMISSION
 INVESTMENTS
 (Unaudited)
 December 31, 2016

FUND SOURCE	COUPON RATE	PURCHASE DATE	MATURITY DATE		YIELD TO MATURITY (COST)	PAR VALUE	AMORTIZED COST	AMORTIZED DISCOUNT (PREMIUM)	PURCHASE PRICE	ACCRUED INTEREST 12/31/16
Water Fund Operating Reserve (01-121800)										
IIIT - Money Market	0.660%	12/31/16	01/01/17	1	0.660%	106,542.74	106,542.74	-	106,542.74	-
US Treasury Notes	0.750%	11/01/12	10/31/17	304	0.740%	25,000.00	25,002.47	41.52	24,960.95	32.11
US Treasury Notes	0.625%	11/05/12	10/31/17	304	0.740%	100,000.00	100,009.89	166.09	99,843.80	128.45
US Treasury Notes	0.875%	10/24/16	11/30/17	334	0.710%	710,000.00	711,035.11	(212.94)	711,248.05	546.15
US Treasury Notes	0.750%	03/08/13	02/28/18	424	0.850%	1,400,000.00	1,398,394.34	5,175.59	1,393,218.75	3,567.68
US Treasury Notes	1.625%	11/14/16	04/30/19	850	1.060%	1,705,000.00	1,727,068.63	(1,241.92)	1,728,310.55	4,745.27
US Treasury Notes	1.000%	08/25/15	11/30/19	1,064	1.340%	850,000.00	841,791.16	3,711.08	838,080.08	747.25
US Treasury Notes	1.250%	09/03/15	02/29/20	1,155	1.470%	100,000.00	99,331.36	272.77	99,058.59	424.72
US Treasury Notes	1.250%	10/08/15	02/29/20	1,155	1.320%	1,000,000.00	997,963.13	775.63	997,187.50	4,247.24
US Treasury Notes	1.250%	11/05/15	02/29/20	1,155	1.550%	1,050,000.00	1,040,292.00	3,417.00	1,036,875.00	4,459.60
US Treasury Notes	2.000%	12/04/15	07/31/20	1,308	1.580%	1,075,000.00	1,090,733.22	(4,549.01)	1,095,282.23	8,997.28
US Treasury Notes	2.125%	12/30/15	08/31/20	1,339	1.740%	575,000.00	582,873.87	(2,076.33)	584,950.20	4,151.67
US Treasury Notes	1.750%	02/03/16	10/31/20	1,400	1.350%	740,000.00	751,140.17	(2,561.39)	753,701.56	2,217.96
US Treasury Notes	2.625%	05/03/16	11/15/20	1,415	1.210%	2,400,000.00	2,527,833.07	(21,041.93)	2,548,875.00	8,179.56
US Treasury Notes	2.000%	03/24/16	11/30/20	1,430	1.380%	2,000,000.00	2,047,024.16	(8,991.47)	2,056,015.63	3,516.48
US Treasury Notes	2.375%	03/31/16	12/31/20	1,461	1.280%	775,000.00	807,924.44	(6,007.20)	813,931.64	50.85
US Treasury Notes	2.000%	07/06/16	02/28/21	1,520	0.920%	775,000.00	809,010.77	(3,891.57)	812,902.34	5,266.57
US Treasury Notes	1.250%	06/27/16	03/31/21	1,551	0.980%	1,265,000.00	1,279,420.99	(1,688.00)	1,281,108.99	4,040.01
US Treasury Notes	2.000%	09/01/16	05/31/21	1,612	1.220%	1,950,000.00	2,015,327.09	(4,751.04)	2,020,078.13	3,428.57
US Treasury Notes	2.000%	10/05/16	08/31/21	1,704	1.210%	1,275,000.00	1,320,556.55	(2,305.75)	1,322,862.30	8,664.36
US Treasury Notes	2.000%	12/05/16	08/31/21	1,704	1.930%	2,150,000.00	2,156,294.36	(88.45)	2,156,382.81	14,610.50
Inter-American Development Bank	1.000%	04/12/16	05/13/19	863	1.100%	790,000.00	788,177.23	547.23	787,630.00	1,053.33
African Development Bank Note	1.125%	09/14/16	09/20/19	993	1.160%	505,000.00	504,514.04	49.34	504,464.70	1,593.91
Intl Bank of Recons and Dev Notes (World Bank)	1.625%	03/14/16	03/09/21	1,529	1.730%	925,000.00	921,277.08	680.08	920,597.00	4,676.39
MS ST Taxable GO Bonds	1.472%	02/18/15	10/01/18	639	1.470%	150,000.00	150,000.00	-	150,000.00	552.00
NYC, NY Taxable GO Bonds	1.650%	03/31/15	10/01/18	639	1.650%	565,000.00	565,000.00	-	565,000.00	2,330.63
CT ST Taxable GO Bonds	1.974%	03/25/15	03/15/19	804	1.970%	300,000.00	300,000.00	-	300,000.00	1,743.70
UNIV OF CAL Taxable Rev Bonds	2.003%	03/25/15	05/15/19	865	2.000%	135,000.00	135,000.00	-	135,000.00	345.52
FL ST Board Admin Fin Corp Taxable Rev Bonds	2.163%	03/08/16	07/01/19	912	2.160%	925,000.00	925,000.00	-	925,000.00	10,003.88
CT ST Taxable GO Bonds	1.300%	08/03/16	08/15/19	957	1.230%	710,000.00	711,345.77	(187.83)	711,533.60	3,435.61
MS ST Taxable GO Bonds	1.679%	02/18/15	10/01/19	1,004	1.680%	310,000.00	310,000.00	-	310,000.00	1,301.23
NY Trans Fin Auth, NY Txb Rev Bonds	2.750%	04/23/15	02/01/20	1,127	1.880%	375,000.00	384,718.53	(5,097.72)	389,816.25	4,296.88
NY Trans Fin Auth, NY Txb Rev Bonds	1.500%	07/14/16	05/01/21	1,582	1.500%	600,000.00	600,000.00	-	600,000.00	1,500.00

DU PAGE WATER COMMISSION
INVESTMENTS
(Unaudited)
December 31, 2016

FUND SOURCE	COUPON RATE	PURCHASE DATE	MATURITY DATE		YIELD TO MATURITY (COST)	PAR VALUE	AMORTIZED COST	AMORTIZED DISCOUNT (PREMIUM)	PURCHASE PRICE	ACCRUED INTEREST 12/31/16
Water Fund Operating Reserve (01-121800) Continued...										
FNMA Pool #AJ3174	3.500%	02/17/16	10/01/26	3,561	2.270%	392,943.59	416,487.80	(1,014.76)	417,502.56	1,146.09
FNMA Pool #AT3221	3.500%	06/17/16	03/01/27	3,712	2.270%	462,730.76	512,625.35	(677.79)	513,203.14	1,407.96
FNMA Pool #AS4197	3.500%	07/16/15	01/01/30	4,749	2.620%	301,293.26	316,794.39	(2,199.85)	318,994.24	878.77
FHLMC Pool #U49048	3.000%	03/17/16	08/01/30	4,961	2.350%	431,596.20	448,993.52	(1,552.44)	450,545.96	1,078.99
FNMA Pool #AL7738	3.500%	02/17/16	11/01/30	5,053	2.550%	469,989.08	497,540.53	(2,924.42)	500,464.95	1,370.80
FNMA Series 2015-M1 ASQ2	1.626%	01/30/15	02/01/18	397	1.260%	181,060.99	181,534.11	(1,336.14)	182,870.25	245.34
FNMA Series 2015-M7 ASQ2	1.550%	04/30/15	04/01/18	456	0.830%	175,000.00	175,594.41	(1,154.96)	176,749.37	226.04
FNMA Series 2015-M15 ASQ2	1.899%	11/30/15	01/01/19	731	1.200%	195,000.00	196,142.35	(807.63)	196,949.98	308.44
Fannie Mae Series 2015-M13 ASQ2	1.646%	10/30/15	09/01/19	974	1.080%	425,000.00	427,779.39	(1,476.52)	429,255.91	582.96
Fannie Mae Series 2016-M1 ASQ2	2.132%	01/29/16	02/01/21	1,493	1.680%	925,000.00	932,294.86	(1,938.86)	934,233.72	1,643.42
FNMA Series 2010-18 LV	4.500%	07/21/15	04/01/21	1,552	2.030%	306,747.61	306,747.61	(21,280.63)	328,028.24	1,150.30
Fannie Mae Global Notes	0.875%	11/27/13	10/26/17	299	1.080%	1,300,000.00	1,297,875.59	7,820.59	1,290,055.00	2,053.82
Tennessee Valley Authority Notes	6.250%	08/19/15	12/15/17	349	1.010%	720,000.00	755,791.24	(50,591.48)	806,382.72	2,000.00
FHLB Notes	0.875%	02/18/16	03/19/18	443	0.890%	2,300,000.00	2,299,580.78	293.78	2,299,287.00	5,702.08
FNMA Notes	0.875%	03/04/16	03/28/18	452	0.970%	1,100,000.00	1,098,672.44	872.44	1,097,800.00	2,486.46
FHLMC Reference Note	0.750%	06/23/16	04/09/18	464	0.850%	1,500,000.00	1,498,177.10	742.10	1,497,435.00	2,562.50
Fannie Mae Global Notes	0.875%	05/24/13	05/21/18	506	1.190%	500,000.00	497,839.41	5,414.41	492,425.00	486.11
Fannie Mae Global Notes	0.875%	05/22/13	05/21/18	506	1.050%	1,000,000.00	997,604.81	6,054.81	991,550.00	972.22
Federal Home Loans Banks Agency	0.875%	05/26/16	06/29/18	545	0.990%	1,100,000.00	1,098,096.60	747.60	1,097,349.00	53.47
Federal Home Loans Banks Agency	0.875%	06/23/16	06/29/18	545	0.860%	1,200,000.00	1,200,249.73	(86.27)	1,200,336.00	58.33
FHLB Notes	0.625%	08/11/16	08/07/18	584	0.820%	635,000.00	633,073.80	461.40	632,612.40	1,587.50
FHLB Notes	0.625%	08/08/16	08/07/18	584	0.840%	1,250,000.00	1,245,647.18	1,072.18	1,244,575.00	3,125.00
FHLB Global Note	0.875%	08/25/16	10/01/18	639	0.910%	1,650,000.00	1,649,060.31	182.31	1,648,878.00	3,609.38
FHLMC Reference Note	0.875%	09/15/16	10/12/18	650	0.900%	400,000.00	399,852.28	24.28	399,828.00	1,020.83
FNMA Benchmark Note	1.125%	09/01/15	10/19/18	657	1.180%	2,300,000.00	2,297,838.92	1,564.92	2,296,274.00	5,175.00
Fannie Mae Global Notes	1.625%	10/23/14	11/27/18	696	1.390%	990,000.00	994,444.67	(4,960.33)	999,405.00	1,519.38
FNMA Benchmark Note	1.375%	01/08/16	01/28/19	758	1.180%	275,000.00	274,883.00	53.50	274,829.50	1,607.03
FNMA Benchmark Note	1.000%	02/23/16	02/26/19	787	1.080%	1,100,000.00	1,098,133.82	729.82	1,097,404.00	3,819.44
FNMA Benchmark Note	1.000%	08/05/16	02/26/19	787	0.900%	2,255,000.00	2,259,826.40	(878.75)	2,260,705.15	7,829.86
Freddie Mac Notes	1.125%	03/24/16	04/15/19	835	1.150%	1,700,000.00	1,699,078.02	302.02	1,698,776.00	4,037.50
FNMA Notes	1.750%	06/30/16	06/20/19	901	0.800%	1,000,000.00	1,023,069.19	(4,640.81)	1,027,710.00	534.72
FHLB Global Note	1.125%	06/02/16	06/21/19	902	1.140%	1,050,000.00	1,049,640.15	81.15	1,049,559.00	328.13
FHLMC Reference Note	0.875%	07/20/16	07/19/19	930	0.960%	1,500,000.00	1,496,620.71	580.71	1,496,040.00	5,869.79
FNMA Benchmark Note	0.875%	07/29/16	08/02/19	944	0.930%	1,600,000.00	1,597,678.54	366.54	1,597,312.00	5,794.44
FHLB Global Note	0.875%	08/03/16	08/05/19	947	0.940%	600,000.00	599,002.85	154.85	598,848.00	2,143.75
FHLB Notes	1.375%	11/17/16	11/15/19	1,049	1.380%	1,790,000.00	1,789,604.71	16.41	1,789,588.30	3,008.19
FNMA Benchmark Note	1.750%	12/03/14	11/26/19	1,060	1.610%	475,000.00	476,815.56	(1,248.19)	478,063.75	808.16
FHLB Global Note	1.125%	08/02/16	07/14/21	1,656	1.210%	1,000,000.00	996,471.88	311.88	996,160.00	5,218.75
FHLB Global Note	1.125%	07/14/16	07/14/21	1,656	1.250%	1,525,000.00	1,516,558.50	832.02	1,515,726.48	7,958.59
Weighted Avg Maturity			1,090		1.232%	\$ 66,417,904.23	\$ 66,984,324.68	\$ (119,846.33)	\$ 67,104,171.01	\$ 206,264.90

DU PAGE WATER COMMISSION
INVESTMENTS
(Unaudited)
December 31, 2016

FUND SOURCE	COUPON RATE	PURCHASE DATE	MATURITY DATE		YIELD TO MATURITY (COST)	PAR VALUE	AMORTIZED COST	AMORTIZED DISCOUNT (PREMIUM)	PURCHASE PRICE	ACCRUED INTEREST 12/31/16
Water Fund L-T Water Capital Reserve (01-121900)										
IIIT - Money Market (PFM Asset Management)	0.660%	12/31/16	01/01/17	1	0.660%	13,992.47	13,992.47	-	13,992.47	-
US Treasury Notes	0.625%	03/28/16	08/31/17	243	0.790%	445,000.00	444,515.27	558.24	443,957.03	945.01
US Treasury Notes	0.625%	05/15/14	11/30/17	334	1.030%	425,000.00	423,428.32	4,454.69	418,973.63	233.52
US Treasury Notes	0.750%	12/31/13	02/28/18	424	1.380%	485,000.00	481,520.09	8,758.76	472,761.33	1,235.95
US Treasury Notes	0.625%	05/13/13	04/30/18	485	0.820%	105,000.00	104,725.83	734.82	103,991.01	112.40
US Treasury Notes	0.625%	05/15/13	04/30/18	485	0.820%	180,000.00	179,535.49	1,244.08	178,291.41	192.68
US Treasury Notes	1.125%	04/24/15	04/30/20	1,216	1.350%	300,000.00	297,822.09	1,068.18	296,753.91	578.04
US Treasury Notes	1.750%	02/03/16	10/31/20	1,400	1.350%	250,000.00	253,763.57	(865.34)	254,628.91	749.31
US Treasury Notes	2.000%	03/28/16	11/30/20	1,430	1.380%	265,000.00	271,262.09	(1,180.68)	272,442.77	465.93
US Treasury Notes	1.625%	11/14/16	11/30/20	1,430	1.400%	320,000.00	322,711.68	(88.32)	322,800.00	459.67
US Treasury Notes	2.000%	03/28/16	10/31/21	1,765	1.520%	275,000.00	281,094.12	(920.53)	282,014.65	941.99
US Treasury Notes	1.875%	01/12/15	11/30/21	1,795	1.780%	260,000.00	261,218.09	(457.69)	261,675.78	428.57
US Treasury Notes	1.500%	12/30/15	01/31/22	1,857	2.040%	75,000.00	73,058.77	361.50	72,697.27	470.79
US Treasury Notes	1.500%	09/03/15	01/31/22	1,857	1.870%	350,000.00	343,768.30	1,533.92	342,234.38	2,197.01
US Treasury Notes	1.625%	02/26/15	08/15/22	2,053	1.820%	175,000.00	173,211.65	549.54	172,662.11	1,074.13
US Treasury Notes	1.625%	12/04/15	11/15/22	2,145	1.930%	200,000.00	196,680.29	570.91	196,109.38	421.96
US Treasury Notes	1.750%	04/24/15	05/15/23	2,326	1.790%	390,000.00	389,023.55	242.30	388,781.25	886.12
US Treasury Notes	1.375%	09/01/16	08/31/23	2,434	1.470%	275,000.00	273,339.08	79.31	273,259.77	1,284.79
US Treasury Notes	2.750%	12/05/16	11/15/23	2,510	2.260%	60,000.00	61,858.69	(18.65)	61,877.34	214.23
US Treasury Notes	2.750%	03/28/16	11/15/23	2,510	1.720%	150,000.00	159,943.68	(1,030.93)	160,974.61	535.57
US Treasury Notes	2.750%	10/09/15	11/15/23	2,510	1.910%	155,000.00	163,378.66	(1,387.55)	164,766.21	553.42
US Treasury Notes	2.750%	05/26/16	11/15/23	2,510	1.650%	275,000.00	294,530.83	(1,566.83)	296,097.66	981.87
US Treasury Notes	2.750%	10/05/16	02/15/24	2,602	1.460%	75,000.00	81,530.82	(207.46)	81,738.28	779.04
US Treasury Notes	2.375%	03/28/16	08/15/24	2,784	1.810%	200,000.00	207,945.06	(734.63)	208,679.69	1,794.16
US Treasury Notes	2.125%	05/03/16	05/15/25	3,057	1.760%	150,000.00	154,251.75	(306.84)	154,558.59	413.85
US Treasury Notes	2.250%	07/06/16	11/15/25	3,241	1.320%	105,000.00	113,194.28	(419.00)	113,613.28	306.73
US Treasury Notes	2.250%	06/27/16	11/15/25	3,241	1.450%	115,000.00	122,629.41	(407.11)	123,036.52	335.95
Inter-American Development Bank	1.000%	04/12/16	05/13/19	863	1.100%	140,000.00	139,676.98	96.98	139,580.00	186.67
Intl Bank of Recons and Dev Notes (World Bank)	1.625%	03/14/16	03/09/21	1,529	1.730%	150,000.00	149,396.28	110.28	149,286.00	758.33
Asian Development Bank Note	1.625%	03/16/16	03/16/21	1,536	1.640%	150,000.00	149,902.18	17.68	149,884.50	710.94
NYC, NY Taxable GO Bonds	1.650%	03/31/15	10/01/18	639	1.650%	95,000.00	95,000.00	-	95,000.00	391.88
FL ST Board Admin Fin Corp Taxable Rev Bonds	2.163%	03/08/16	07/01/19	912	2.160%	150,000.00	150,000.00	-	150,000.00	1,622.25
MS ST Taxable GO Bonds	1.679%	02/18/15	10/01/19	1,004	1.680%	40,000.00	40,000.00	-	40,000.00	167.90
NY Trans Fin Auth, NY Txb1 Rev Bonds	2.750%	04/23/15	02/01/20	1,127	1.880%	75,000.00	76,943.71	(1,019.54)	77,963.25	859.38
CT ST Taxable GO Bonds	2.294%	03/25/15	03/15/20	1,170	2.290%	70,000.00	70,000.00	-	70,000.00	472.82
UNIV OF CAL Taxable Rev Bonds	2.253%	03/25/15	05/15/20	1,231	2.250%	50,000.00	50,000.00	-	50,000.00	143.94
NY Trans Fin Auth, NY Txb1 Rev Bonds	1.500%	07/14/16	05/01/21	1,582	1.500%	100,000.00	100,000.00	-	100,000.00	250.00
FNMA Pool #AJ3174	3.500%	02/17/16	10/01/26	3,561	2.270%	62,939.03	66,710.18	(162.53)	66,872.71	183.57
FNMA Pool #AT3221	3.500%	06/17/16	03/01/27	3,712	2.270%	88,214.76	93,677.73	(105.59)	93,783.32	257.29
FNMA Pool #AS4197	3.500%	07/16/15	01/01/30	4,749	2.620%	74,437.17	78,266.86	(543.49)	78,810.35	217.11
FHLMC Pool #U49048	3.000%	03/17/16	08/01/30	4,961	2.350%	64,739.42	67,349.01	(232.88)	67,581.89	161.85
FNMA Pool #AL7738	3.500%	02/17/16	11/01/30	5,053	2.550%	77,571.02	82,118.35	(482.67)	82,601.02	226.25

DU PAGE WATER COMMISSION
 INVESTMENTS
 (Unaudited)
 December 31, 2016

FUND SOURCE	COUPON RATE	PURCHASE DATE	MATURITY DATE		YIELD TO MATURITY (COST)	PAR VALUE	AMORTIZED COST	AMORTIZED DISCOUNT (PREMIUM)	PURCHASE PRICE	ACCRUED INTEREST 12/31/16
Water Fund L-T Water Capital Reserve (01-121900) Continued...										
FNMA Series 2015-M15 ASQ2	1.899%	11/30/15	01/01/19	731	1.200%	45,000.00	45,263.62	(186.38)	45,450.00	71.18
Fannie Mae Series 2015-M13 ASQ2	1.646%	10/30/15	09/01/19	974	1.080%	80,000.00	80,523.18	(277.93)	80,801.11	109.73
Fannie Mae Series 2016-M1 ASQ2	2.132%	01/29/16	02/01/21	1,493	1.680%	175,000.00	176,380.11	(366.81)	176,746.92	310.92
FNMA SERIES 2015	2.013%	03/31/15	07/01/22	2,008	1.710%	20,824.07	20,974.46	(57.47)	21,031.93	34.93
Fannie Mae Global Notes	0.875%	05/15/14	05/21/18	506	1.300%	425,000.00	422,502.89	4,604.64	417,898.25	413.19
FHLB Notes	0.625%	08/11/16	08/07/18	584	0.820%	235,000.00	234,287.15	170.75	234,116.40	587.50
Fannie Mae Global Notes	1.625%	12/31/13	11/27/18	696	1.780%	475,000.00	473,648.78	2,040.28	471,608.50	728.99
Fannie Mae Benchmark Notes	1.875%	05/15/14	02/19/19	780	1.550%	400,000.00	402,718.62	(3,225.38)	405,944.00	2,750.00
FHLB Global Note	1.125%	06/02/16	06/21/19	902	1.140%	375,000.00	374,871.48	28.98	374,842.50	117.19
FHLB Global Note	1.125%	07/13/16	07/14/21	1,656	1.230%	250,000.00	248,878.73	111.23	248,767.50	1,304.69
FNMA Notes	2.125%	04/26/16	04/24/26	3,401	2.210%	210,000.00	208,458.50	100.70	208,357.80	830.52
		Weighted Avg Maturity	1.525		1.527%	\$ 10,152,717.94	\$ 10,241,482.73	\$ 11,185.54	\$ 10,230,297.19	\$ 32,461.71
Capital Reserve (01-122000)										
IIIT - Money Market (PFM Asset Management)	0.660%	12/31/16	01/01/17	1	0.660%	123,688.86	123,688.86	-	123,688.86	-
US Treasury Notes	0.875%	12/31/14	01/31/18	396	1.160%	800,000.00	797,584.42	4,396.92	793,187.50	2,929.35
US Treasury Notes	1.500%	12/04/15	12/31/18	730	1.220%	975,000.00	980,407.62	(2,857.03)	983,264.65	40.40
US Treasury Notes	1.625%	11/14/16	04/30/19	850	1.060%	915,000.00	926,843.28	(666.49)	927,509.77	2,546.58
US Treasury Notes	1.500%	12/05/16	11/30/19	1,064	1.450%	1,775,000.00	1,777,705.95	(67.49)	1,777,773.44	2,340.66
Intl Bank of Recons and Dev Notes (World Bank)	0.875%	04/12/16	07/19/18	565	0.950%	600,000.00	599,264.94	326.94	598,938.00	2,362.50
African Development Bank Note	1.625%	10/31/16	10/02/18	640	1.120%	200,000.00	201,754.42	(159.58)	201,914.00	803.47
Inter-American Development Bank	1.000%	04/12/16	05/13/19	863	1.100%	420,000.00	419,030.93	290.93	418,740.00	560.00
African Development Bank Note	1.125%	09/14/16	09/20/19	993	1.160%	235,000.00	234,773.86	22.96	234,750.90	741.72
UNIV OF CAL Taxable Rev Bonds	0.934%	03/25/15	05/15/17	135	0.930%	175,000.00	175,000.00	-	175,000.00	208.85
MS ST Taxable GO Bonds	1.090%	02/18/15	10/01/17	274	1.090%	35,000.00	35,000.00	-	35,000.00	95.38
Regional Trans Auth, IL Rev Bonds	1.250%	04/26/16	05/04/18	489	1.250%	600,000.00	600,000.00	-	600,000.00	1,875.00
FL ST Board Admin Fin Corp Taxable Rev Bonds	2.163%	03/08/16	07/01/19	912	2.160%	600,000.00	600,000.00	-	600,000.00	6,489.00
CT ST Taxable GO Bonds	1.300%	08/03/16	08/15/19	957	1.230%	330,000.00	330,625.50	(87.30)	330,712.80	1,596.83

DU PAGE WATER COMMISSION
INVESTMENTS
(Unaudited)
December 31, 2016

FUND SOURCE	COUPON RATE	PURCHASE DATE	MATURITY DATE		YIELD TO MATURITY (COST)	PAR VALUE	AMORTIZED COST	AMORTIZED DISCOUNT (PREMIUM)	PURCHASE PRICE	ACCRUED INTEREST 12/31/16
Capital Reserve (01-122000) Continued...										
FNMA SERIES 2015 M1	1.626%	01/30/15	02/01/18	397	1.260%	90,530.50	90,767.06	(668.06)	91,435.12	122.67
FNMA SERIES 2015 M7	1.550%	04/30/15	04/01/18	456	1.260%	105,000.00	105,356.65	(692.97)	106,049.62	135.63
FNMA Series 2014-M1 ASQ2	2.323%	09/01/16	11/01/18	670	1.150%	238,825.61	243,038.93	(861.74)	243,900.67	462.33
FNMA Series 2015-M15 ASQ2	1.899%	11/30/15	01/01/19	731	1.200%	130,000.00	130,761.57	(538.42)	131,299.99	205.63
FNMA Series 2016-M9 ASQ2	1.785%	06/09/16	06/01/19	882	1.050%	230,000.00	231,838.75	(461.14)	232,299.89	342.13
Fannie Mae Series 2015-M13 ASQ2	1.646%	10/30/15	09/01/19	974	1.080%	275,000.00	276,798.43	(955.39)	277,753.82	377.21
Freddie Mac Series 4459 NB	4.500%	06/11/15	01/01/20	1,096	0.770%	112,474.16	115,785.62	(2,136.50)	117,922.12	421.78
FNMA Series 2015-M12 FA	0.540%	09/30/15	04/25/20	1,211	0.540%	371,620.89	371,620.89	133.78	371,487.11	278.97
FNMA Series 2010-18 LV	4.500%	07/21/15	04/01/21	1,552	2.030%	214,723.32	214,723.32	(14,896.44)	229,619.76	805.21
Tennessee Valley Authority Notes	6.250%	08/19/15	12/15/17	349	1.010%	480,000.00	503,860.82	(33,727.66)	537,588.48	1,333.33
FHLB Notes	0.875%	02/18/16	03/19/18	443	0.890%	1,475,000.00	1,474,731.15	188.40	1,474,542.75	3,656.77
FNMA Notes	0.875%	03/04/16	03/28/18	452	0.970%	1,475,000.00	1,473,219.87	1,169.87	1,472,050.00	3,334.11
FHLMC Reference Note	0.750%	04/06/16	04/09/18	464	0.830%	725,000.00	724,275.87	414.12	723,861.75	1,238.54
Federal Home Loan Banks Agcy	0.875%	08/11/16	06/29/18	545	0.850%	450,000.00	450,136.72	(34.28)	450,171.00	21.88
Federal Home Loan Banks Agcy	0.875%	05/26/16	06/29/18	545	0.990%	785,000.00	783,641.67	533.52	783,108.15	38.16
FHLB Notes	0.625%	07/07/16	08/07/18	584	0.730%	750,000.00	748,797.90	357.90	748,440.00	1,875.00
FHLB Notes	0.625%	08/10/16	08/07/18	584	0.810%	870,000.00	867,487.34	601.94	866,885.40	2,175.00
FHLB Global Note	0.875%	08/25/16	10/01/18	639	0.910%	550,000.00	549,686.77	60.77	549,626.00	1,203.13
FNMA Benchmark Note	1.125%	09/01/15	10/19/18	657	1.180%	1,475,000.00	1,473,614.09	1,003.59	1,472,610.50	3,318.75
FHLB Notes	1.250%	12/08/16	01/16/19	746	1.250%	700,000.00	699,972.00	-	699,972.00	559.03
FNMA Benchmark Note	1.375%	01/08/16	01/28/19	758	1.400%	1,255,000.00	1,254,466.04	244.14	1,254,221.90	7,333.91
FNMA Benchmark Note	1.000%	02/23/16	02/26/19	787	1.080%	1,475,000.00	1,472,497.62	978.62	1,471,519.00	5,121.53
Freddie Mac Notes	1.125%	03/31/16	04/15/19	835	1.050%	925,000.00	926,663.76	(537.74)	927,201.50	2,196.88
FHLB Global Note	1.125%	06/27/16	06/21/19	902	0.820%	1,125,000.00	1,133,482.96	(1,713.46)	1,135,196.42	351.56
FHLMC Reference Note	0.875%	07/19/16	07/19/19	930	0.960%	650,000.00	648,658.89	231.89	648,427.00	2,543.58
FNMA Benchmark Note	0.875%	07/29/16	08/02/19	944	0.930%	750,000.00	748,911.82	171.82	748,740.00	2,716.15
FNMA Notes	0.875%	08/31/16	08/28/19	970	1.050%	1,675,000.00	1,672,671.93	284.93	1,672,387.00	5,536.81
FHLB Global Note	1.000%	10/03/16	09/26/19	999	1.010%	750,000.00	749,758.50	21.00	749,737.50	1,979.17
Credit Agricole CIB NY CP	0.000%	08/09/16	02/03/17	34	1.280%	600,000.00	599,301.50	3,764.83	595,536.67	-
Bank of Montreal Chicago	0.000%	06/16/16	03/03/17	62	1.040%	600,000.00	598,952.83	4,892.83	594,060.00	-
BNP Paribas NY CP	0.000%	10/21/16	07/18/17	199	1.330%	600,000.00	595,644.00	(609.50)	596,253.50	-
Weighted Avg Maturity			698		1.094%	\$ 29,691,863.34	\$ 29,732,805.05	\$ (41,579.49)	\$ 29,774,384.54	\$ 72,274.59
TOTAL ALL FUNDS					1.126%	\$ 143,116,550.42	\$ 143,752,706.43	\$ (132,715.43)	\$ 143,885,421.86	\$ 321,073.08
Less: Net Unsettled Trades							\$ 143,752,706.43			
December 31, 2016					90 DAY US TREASURY YIELD	0.51%		Longest Maturity	3,401	\$ 210,000.00
					3 month US Treasury Bill Index	0.43%				
					0-3 Year US Treasury Index	0.99%				
					1-3 Year US Treasury Index	1.16%				
					1-5 Year US Treasury Index	1.40%				
					1-10 Year US Treasury Index	1.63%				

DUPAGE WATER COMMISSION
 ELMHURST, ILLINOIS
 TREASURER'S REPORT
 STATEMENT OF CASH FLOWS
 For the Period from May 1, 2016 to December 31, 2016

CASH FLOWS FROM OPERATING ACTIVITIES

Cash received from customers	\$	91,420,014
Cash payments to suppliers		(75,881,228)
Cash payments to employees		(2,024,916)
Net cash from operating activities		13,513,870

CASH FLOWS FROM NONCAPITAL
FINANCING ACTIVITIES

Cash received from sales taxes		12,426,342
Cash Received from water quality loans		49,043
Cash payments for net pension activity		(300,000)
Net cash from noncapital financing activities		12,175,385

CASH FLOWS FROM CAPITAL AND
RELATED FINANCING ACTIVITIES

Interest paid		(43)
Principal Paid		(3,240)
Construction and purchase of capital assets		(3,309,888)
Net cash from capital and related financing activities		(3,313,171)

CASH FLOWS FROM INVESTING ACTIVITIES

Investment income		1,123,914
Net cash from investing activities		1,123,914

Net Increase (Decrease) in cash and investments 23,499,998

CASH AND INVESTMENTS, MAY 1, 2016 136,290,161

CASH AND INVESTMENTS, DEC 31, 2016 \$ 159,790,159

December 31, 2016
 TREASURER'S REPORT
 DPWC MONTHLY CASH/OPERATING REPORT



	12/31/2016		
	YEAR END TARGETED Reserve or Monthly Cash Amount-Needed	Amount On Hand	Amount Over - (Under) Target
TABLE 1	A	B	C
RESERVE ANALYSIS			
A. Operating Reserve # of days per current fiscal year management budget	\$ 39,602,480 120	\$ 66,984,325 203	\$ 27,381,845
B. Capital Reserve	\$ 29,361,790	\$ 29,425,606	\$ 63,816
C. Long Term Water Capital Reserve	\$ 9,925,000	\$ 10,241,483	\$ 316,483
D. O+M Account (1)	\$ 9,080,491	\$ 31,036,938	\$ 21,956,447
E. Current Construction Obligation and Customer Construction Escrows	\$ 307,199	\$ 307,199	\$ -
TOTAL SUMMARY CASH + RESERVE ANALYSIS	\$ 88,276,960	\$ 137,995,551	\$ 49,718,590

TABLE 2		
OTHER CASH		
F. General Fund		\$ 19,661,276
G. Sales Tax		\$ 2,133,332
TOTAL TABLE 2-OTHER CASH		\$ 21,794,609
TOTAL MONTH END FUNDS CASH BALANCE-Table1+2		\$ 159,790,159

Note 1: The O&M Account target varies from month to month. The cash balance should be enough to cover the current months operating cash outflows.

DATE: January 3, 2017

REQUEST FOR BOARD ACTION

AGENDA SECTION	Finance Committee	ORIGINATING DEPARTMENT	Finance
ITEM	Authorizing the Transfer of Funds from the Sales Tax Account to the Long Term Water Capital Reserve Account	APPROVAL	 
Account Numbers: 01-123000 and 01-121900			
<p>The request is to transfer funds into the Long Term Water Capital Reserve. The transfer would allow the Commission to fully fund the Long Term Water Capital revised target based upon the anticipated proposal for the 2017-2018 Management Budget. The 2017-2018 Management Budget is to be voted on by the Board during the April 20, 2017 Board meeting.</p> <p>The transfer would be for a total of approximately \$2.1 million from the Sales Tax Account to the Long Term Water Capital Reserve.</p> <p>The targeted monthly amount to be transferred for the Long Term Water Capital Reserve should be based upon anticipated costs related to long-term capital spending or monthly depreciation expense but no less than \$175,000 per month or \$2.1 million per year. The Purpose of the designated Long-Term Water Capital Reserve Fund is to accumulate sufficient reserve funds for the future that are necessary to insure timely acquisition, replacement and upgrade of the Commission's water system infrastructure.</p>			
MOTION: Authorizing the Transfer of Funds from the Sales Tax Account to the Long Term Water Capital Reserve Account			

DATE: January 12, 2017

REQUEST FOR BOARD ACTION

AGENDA SECTION	Administration Committee	ORIGINATING DEPARTMENT	General Manager's Office
ITEM	An Ordinance Approving and Authorizing the Execution of a Water Purchase and Sale Contract Between the DuPage Water Commission and the Village of Bartlett for the Village of Bartlett Unit System Ordinance No. O-1-17	APPROVAL	
Account No.: N/A			
Ordinance No. O-1-17 would authorize and direct the Chairman to execute a Water Purchase and Sale Contract for the Village of Bartlett Unit System with the Village of Bartlett in substantially the form attached in Exhibit A.			
MOTION: To approve Ordinance No. O-1-17.			

DUPAGE WATER COMMISSION

ORDINANCE NO. O-1-17

AN ORDINANCE APPROVING AND AUTHORIZING THE EXECUTION OF A WATER PURCHASE AND SALE CONTRACT BETWEEN THE DUPAGE WATER COMMISSION AND THE VILLAGE OF BARTLETT FOR THE VILLAGE OF BARTLETT UNIT SYSTEM

WHEREAS, the DuPage Water Commission (the "Commission") was formed and exists pursuant to the Water Commission Act of 1985 (70 ILCS 3720/1 *et seq.*) and Division 11 of Article 135 of the Illinois Municipal Code (65 ILCS 5/11-135-1 *et seq.*) (collectively the "Act") for the purpose of financing, constructing, and operating a water supply system to serve its Charter Customers and other customers in DuPage County with a common source of supply of water from Lake Michigan; and

WHEREAS, the Village of Bartlett ("Bartlett") owns and operates a waterworks system known as the Village of Bartlett Unit System; and

WHEREAS, Bartlett desires to purchase Lake Michigan water from the Commission; and

WHEREAS, the Commission and Bartlett have each determined that it is in their respective best interests to enter into a Water Purchase and Sale Contract for the Bartlett in substantially the form attached hereto and by this reference incorporated herein and made a part of as Exhibit A.

NOW, THEREFORE, BE IT ORDAINED, by the Board of Commissioners of the DuPage Water Commission as follows:

SECTION ONE: The foregoing recitals are hereby incorporated herein as findings of the Board of Commissioners of the DuPage Water Commission.

SECTION TWO: A Water Purchase and Sale Contract between the DuPage Water Commission and the Village of Bartlett for the Village of Bartlett Unit System, in substantially the form attached hereto as Exhibit A, is hereby approved.

SECTION THREE: The Chairman of the DuPage Water Commission shall be and hereby is authorized to and directed to execute a Water Purchase and Sale Contract for the Village of Bartlett Unit System with the Village of Bartlett in substantially the form attached hereto as Exhibit A; provided, however, that said Water Purchase and Sale Contract shall not be so executed on behalf of the DuPage Water Commission unless and until the Chairman shall have been presented with copies of the completed Water Purchase and Sale Contract executed by the Village of Bartlett.

SECTION FOUR: Upon execution by the Chairman, the Water Purchase and Sale Contract, and all other things provided for therein, shall be deemed accepted by the DuPage Water Commission without further act.

SECTION FIVE: This Ordinance shall be in full force and effect from and after its adoption by a majority affirmative vote of all the Commissioners including the affirmative vote of at least 1/3 of the Commissioners appointed by the County Board Chairman and 40 percent of the Commissioners appointed by the Mayors.

AYES:

NAYS:

ABSENT:

ADOPTED this 19th day of January, 2017

Chairman

ATTEST:

Clerk

EXHIBIT A

DUPAGE WATER COMMISSION

WATER PURCHASE AND SALE CONTRACT

Between

The DuPage Water Commission

and

The Village of Bartlett

FOR THE VILLAGE OF BARTLETT UNIT SYSTEM

February 7, 2017

**DUPAGE WATER COMMISSION
WATER PURCHASE AND SALE CONTRACT
WITH THE VILLAGE OF BARTLETT**

Table of Contents

	Page
SECTION 1. PREAMBLES	3
SECTION 2. DEFINITIONS.....	3
SECTION 3. WATER SUPPLY.....	13
A. Agreement to Sell and Purchase.....	13
B. Beginning of Obligations to Deliver and Receive Lake Water.....	14
C. Limits on Supply	14
D. Emergency or Maintenance Turn-Off.....	14
E. Curtailment; Emergency Use of Other Sources	15
F. Water Quality	16
SECTION 4. DELIVERY; STORAGE; DISTRIBUTION; CONSERVATION.....	16
A. Bartlett Unit System Connection Facilities	16
B. Storage	16
C. Metering of Shallow Wells.....	18
D. Surges and Back-Flows	18
E. Maintenance of System; Water Quality; Prevention of Waste.....	18
SECTION 5. MEASURING EQUIPMENT	19
A. Metering Station and Instrumentation	19
B. Records	20
C. Calibration	20
D. Check Meters	21
E. Meter Malfunctions.....	21
F. Removal of Metering Station and SCADA System Facilities.....	22
SECTION 6. UNIT OF MEASUREMENT.....	22
SECTION 7. PRICES AND TERMS OF PAYMENT.....	23
A. Operation and Maintenance Costs Payment.....	23
B. Fixed Costs Payment	23
C. Connection Facilities Cost Payment.....	25
D. Capital Cost Recovery Charge Payment.....	26

E.	Underconsumption Costs Payment	27
F.	Default Shares	28
G.	Bills and Due Date	28
H.	Disputed Payments.....	29
I.	Interest on Overdue Payments	29
J.	Security Deposit.....	30
K.	Prepayments.....	31
L.	Enforcement of Provisions Hereof By Other Customers.....	33
M.	Beginning of Obligation to Pay	33
N.	Provisions in Lieu of Water Allocation	34

SECTION 8. SPECIAL CONDITIONS AND COVENANTS34

A.	Construction of the Commission Connection Facilities; No Delay Damages; Supply of Lake Water	34
B.	Lake Water Only; Costs.....	35
C.	Title to Lake Water	36
D.	Emergency Supply	36
E.	Covenants to Be Set Out in Bond Ordinance.....	36
F.	Payments Hereunder an Operation Expense of Bartlett Unit System.....	36

SECTION 9. ADDITIONAL BARTLETT COVENANTS37

A.	Maintenance of Corporate Existence.....	37
B.	Maintenance and Operation of Bartlett Unit System.....	37
C.	Rate Covenant.....	38
D.	Future Subordination of Obligations	38
E.	General Covenant to Operate Properly.....	39
F.	Accounting and Audit.....	39
G.	Maintain Ownership of Bartlett Unit System	39
H.	Insurance.....	40
I.	Continue to Serve.....	40
J.	Maintain Water Allocation	40
K.	Release and Indemnification.....	40
L.	Combining or Separating System Accounts	41
M.	Rate of Withdrawal.....	42
N.	Emergency Interconnections.....	42

SECTION 10. SCHEDULE FOR COMPLETION OF VARIOUS FACILITIES44

A.	Plans and Specifications for Bartlett Unit System Connection Facilities	44
B.	IEPA and Other Approvals For Bartlett Unit System Connection Facilities.....	45

C.	Commencement of Construction of Bartlett Unit System Connection Facilities.....	45
D.	Plans and Specifications for Water Storage Facilities	45
E.	IEPA and Other Approvals for Water Storage Facilities	46
F.	Commencement of Construction of Water Storage Facilities.....	46
G.	Transfer of Property Rights.....	46
H.	Commencement of Construction of Commission Connection Facilities	46
I.	Delivery of Water for Start-Up Purposes	47
J.	Illustrative Schedule of Events.....	48
SECTION 11.	ASSIGNABILITY.....	48
SECTION 12.	FORCE MAJEURE.....	49
SECTION 13.	COMMISSION DEFAULTS	50
SECTION 14.	BARTLETT OBLIGATION UNCONDITIONAL.....	50
SECTION 15.	COOPERATION IN CONSTRUCTION; EASEMENTS.....	51
SECTION 16.	COOPERATION IN ISSUANCE OF BONDS.....	52
SECTION 17.	REGULATORY BODIES.....	52
SECTION 18.	OTHER WATER SUPPLIERS.....	53
SECTION 19.	NOTICES; EVIDENCE OF ACTIONS; WAIVER.....	53
A.	Notices	53
B.	Evidence of Actions	54
C.	Waiver	54
SECTION 20.	EFFECTIVE DATE; TERMINATION; PAYMENT OF INTERIM COSTS; TERM	54
A.	Effective Date.....	54
B.	IDNR Approval	55
C.	Commission Right to Terminate	55
D.	Payment of Interim Costs	55
E.	Term	56
SECTION 21.	GOVERNING LAW AND VENUE.....	57
SECTION 22.	MODIFICATIONS OR AMENDMENTS	57

SECTION 23. EXHIBITS INCORPORATED..... 57

SECTION 24. EXECUTION IN COUNTERPARTS57

DRAFT

**DUPAGE WATER COMMISSION
WATER PURCHASE AND SALE CONTRACT WITH THE VILLAGE BARTLETT
FOR THE VILLAGE OF BARTLETT UNIT SYSTEM**

This Water Purchase and Sale Contract the (“Contract”), dated as of _____, 2017, by and between the **DUPAGE WATER COMMISSION**, DuPage, Cook, and Will Counties, State of Illinois (the “Commission”), a county water commission and public corporation under Division 135 of Article 11 of the Illinois Municipal Code, 65 ILCS 5/11-135-1 *et seq.*, and the Water Commission Act of 1985, 70 ILCS 3720/1 *et seq.* (collectively, the “Acts”), and the **VILLAGE OF BARTLETT**, Illinois, a municipal corporation duly organized and existing under the laws of the State of Illinois (“Bartlett”);

WITNESSETH:

WHEREAS, the Commission has been organized under the Acts to supply water within its territorial limits; and

WHEREAS, Bartlett is in the process of designing and constructing a waterworks system that will be owned and operated by Bartlett and extended or improved from time to time to meet the potable water requirements of all residents and businesses to be served with water from Bartlett, which waterworks system is preliminarily depicted in Exhibit A attached to this Contract; and

WHEREAS, Bartlett desires that the waterworks system preliminarily depicted in Exhibit A attached to this Contract as well as any extensions or improvements of that system (the “Bartlett Unit System”) be served with water from the Commission; and

WHEREAS, Bartlett will apply to the State of Illinois Department of Natural Resources,

Office of Water Resources, a water allocation for the Bartlett Unit System; and

WHEREAS, the Commission has entered into a contract with the City of Chicago to purchase Lake Michigan water sufficient to meet the water supply needs of the Commission and its customers (the "Chicago Contract"); and

WHEREAS, the Commission has issued and sold and further proposes to issue and sell Bonds (as defined in Section 2 below) from time to time during the term of this Contract in sufficient amounts for the payment of the costs of its project of acquiring, designing, constructing, and maintaining its Waterworks System (as defined in Section 2 below); and

WHEREAS, such Bonds have been and will be issued from time to time by the Commission pursuant to Bond Ordinances (as defined in Section 2 below) adopted by the Commission; and

WHEREAS, pursuant to the Acts, Article VII, Section 10 of the Illinois Constitution of 1970, and the Intergovernmental Cooperation Act, 5 ILCS 220/1 *et seq.*, the Commission and Bartlett are authorized to enter into this Contract; and

WHEREAS, by the execution of this Contract, Bartlett is surrendering none of its rights to the ownership and operation of the Bartlett Unit System, except as expressly provided for, and only to the limited extent so provided for, in this Contract, and Commission is surrendering none of its rights to the ownership and operation of its Waterworks System, but each asserts its continued right to operate such systems; and

WHEREAS, Bartlett recognizes that the Commission may use this Contract as the basis, in part, for obtaining loans from time to time to be evidenced by the issuance of its Bonds; and for payment of the principal of and the premium, if any, and interest on such Bonds; and as the

means for the payment of its maintenance and operating expenses; and for such purposes as may be authorized by applicable statutes or required in any Bond Ordinance adopted by the Commission authorizing issuance of Bonds; and

WHEREAS, Bartlett recognizes that the Commission may in the future enter into contracts with other customers.

NOW, THEREFORE, in consideration of the foregoing recitals and of the mutual covenants and agreements herein contained, the Commission and Bartlett hereby agree as follows:

SECTION 1. PREAMBLES.

The preambles hereto are hereby incorporated herein by this reference and are made fully a part of this Contract.

SECTION 2. DEFINITIONS.

The following words and phrases shall have the following meanings when used in this Contract.

A. “Acts” means Article 11, Division 135 of the Illinois Municipal Code, 65 ILCS 5/11-135-1 *et seq.*, and the Water Commission Act of 1985, 70 ILCS 3720/1 *et seq.*

B. “Aggregate Costs” means Operation and Maintenance Costs, Fixed Costs, and Underconsumption Costs, collectively, as defined herein.

C. “Alternate Delivery” means the delivery of Lake Water purchased by Bartlett from the Commission to the Bartlett Unit System through facilities owned by a Contract Customer (commonly referred to as “wheeling”).

D. “Average Charter Customer Rate Per 1,000 Gallons” means Total Charter Customer Revenue divided by Total Charter Customer Use.

E. “Bartlett” means the Village of Bartlett, located in Cook, DuPage and Kane Counties, State of Illinois.

F. “Bartlett’s Base Rate” means a water rate stated as dollars or cents per 1,000 gallons that is calculated by (i) subtracting Bartlett's estimated Charter Customer Facilities Credit in the Fiscal Year for which Bartlett's Base Rate pursuant to this Contract is being calculated from the sum of all Operation and Maintenance Cost payments, all Fixed Costs payments, all Connection Facilities Cost payments, and all Capital Cost Recovery Charge payments under the Charter Customer Contract estimated to be made by Bartlett pursuant to this Contract in the Fiscal Year for which Bartlett's Base Rate pursuant to this Contract is being calculated and (ii) dividing the resulting amount by the total amount of Lake Water, stated in 1,000 gallon units, estimated to be delivered to Bartlett in said Fiscal Year.

G. “Bartlett Unit System” means the waterworks system described in Exhibit A attached to this Contract as well as any extensions or improvements of that system acquired by Bartlett and used for the purpose of providing and transmitting water to its customers.

H. “Bartlett Unit System Connection Facilities” means those portions of the Bartlett Unit System, lying downstream from the Point of Delivery, to be constructed pursuant to this Contract by Bartlett at its expense to initially connect the Bartlett Unit System to the Waterworks System, which facilities are depicted in the preliminary plans attached as Exhibit B-1 to this Contract, as such facilities may be relocated, replaced, extended, or improved from time to time. The Bartlett Unit System Connection Facilities include, among other items, the pressure adjusting station described in Subsection 4A of this Contract and pipeline and equipment appurtenant thereto.

I. “Bond Ordinances” means all of the Commission's ordinances and resolutions under which the Commission has or will authorize the issuance of, or issue, Bonds.

J. “Bonds” means Revenue Bonds and Other Bonds.

K. “Capital Cost Recovery Charge” means the amount necessary, pursuant to Section 0.02 of the Water Commission Act of 1985 (as added by Public Act 093-0226) and Commission Resolution No. R-79-04, entitled “A Resolution Expressing the Policy of the DuPage Water Commission Regarding the New Subsequent Customer Pricing Methodology,” to recover Bartlett’s proportionate share of Original Capital Costs less Rebates, where Bartlett’s proportionate share of Original Capital Costs less Rebates is that proportion of Original Capital Costs less Rebates which Bartlett’s Full Water Requirements for 2015 and 2016 as reported by Bartlett to the IEPA bears to the sum of the Full Water Requirements or Minimum Take or Pay Requirements (as defined in the Charter Customer Contract), as applicable, of all of the Commission’s Contract Customers for such two years which the parties agree shall be \$13,030,632 based on the method of calculating such amount illustrated in Exhibit E attached to this Contract.

L. “Charter Customer Contract” means the Water Purchase and Sale Contract between the Commission and the Charter Customers dated as of June 11, 1986.

M. “Charter Customer Facilities” means all of the feeder mains, metering stations, and pressure adjusting stations constructed as of May 1, 1992, solely for the purpose of initially connecting the Charter Customers to the Waterworks System.

N. “Charter Customer Facilities Credit” means a credit intended to compensate Bartlett for the portion of Fixed Costs that is attributable solely to the Charter Customer

Facilities and in lieu of which Bartlett pays its Connection Facilities Cost. For purposes of this Contract, and for so long as Bartlett is entitled to receive its monthly Charter Customer Facilities Credit pursuant to this Contract, Bartlett's monthly Charter Customer Facilities Credit shall be calculated by multiplying the portion of Bartlett's monthly Fixed Costs payment due pursuant to Subsection 7B of this Contract that is attributable to the payment of debt service (principal, premium, if any, and interest) on the Original Revenue Bonds times the factor of .4332, which approximates the portion of Fixed Costs attributable to the Charter Customer Facilities (See Exhibit E).

O. "Charter Customers" means the units of local government (not including the Commission) that are parties to the Charter Customer Contract, excluding, however, any such unit of local government whose rights and obligations under such Contract have been terminated, including without limitation the Village of Bartlett.

P. "Chicago Contract" means the Water Supply Contract, dated March 19, 1984, between the Commission and the City of Chicago, Illinois, as amended or supplemented from time to time.

Q. "Commission" means the DuPage Water Commission, DuPage, Cook, and Will Counties, State of Illinois.

R. "Commission Connection Facilities" means the portions of the Waterworks System constructed by the Commission to initially connect the Bartlett Unit System to the existing Waterworks System, which facilities are depicted in the preliminary plans attached as Exhibit B-2 to this Contract, as such facilities may be relocated, replaced, extended, or improved from time to time. The Commission Connection Facilities include, among other items, a

metering station, including pipelines and equipment appurtenant thereto, and SCADA System facilities attributable to the Bartlett Unit System, including equipment appurtenant thereto.

S. “Connection Facilities” means the Bartlett Unit System Connection Facilities and the Commission Connection Facilities.

T. “Connection Facilities Cost” means the full actual cost incurred by the Commission in connection with (i) the design, bidding, contracting, managing, and actual construction, installation, removal, relocation, replacement, extension, or improvement of the Connection Facilities, including without limitation equipment required for the operation of the Connection Facilities and all administrative, financing, supervisory, inspection, engineering, surveying, and legal fees, costs, and expenses associated therewith; (ii) the acquisition and divestment of lands, easements, and rights of way over lands and waters necessary for the construction, installation, removal, relocation, replacement, extension, or improvement of the Connection Facilities, and all administrative, title, surveying, and legal fees, costs, and expenses associated therewith; and (iii) the review and processing of plans and agreements for the construction, installation, removal, relocation, replacement, extension, or improvement of the Connection Facilities and in connection with the negotiation, preparation, consideration, and review of this Contract, including without limitation all legal, engineering, consulting, and administrative fees, costs, and expenses associated therewith; except as any of the above are included in Operation and Maintenance Costs.

U. “Contract” means this Water Purchase and Sale Contract.

V. “Contract Customers” means the Charter Customers, Bartlett, and every other entity with whom the Commission has entered into, or may in the future enter into, a contract or

agreement for the sale by the Commission of Lake Water to that entity, except only contracts and agreements providing for the delivery of Lake Water during times of emergency only.

W. “Days” means calendar days.

X. “Determination Date” means the last day of December immediately preceding the Interest Period for which the Earned Interest Rate pursuant to this Contract is being calculated, but the effective date of any change in the Earned Interest Rate shall, for purposes hereof, be the first day of May following such Determination Date.

Y. “Earned Interest Rate” means, with respect to each Interest Period under this Contract, the highest monthly average yield to maturity interest rate earned by the Commission (total funds) as reported monthly on the Commission’s Schedule of Investments for the immediate preceding fiscal year (May 1 – April 30) as determined by the Commission, which determination shall be conclusive and binding upon Bartlett absent manifest error, but the effective date of any change in the Earned Interest Rate shall, for purposes hereof, be the first day of May following such Determination Date.

Z. “Fiscal Year” means the fiscal year of the Commission.

AA. “Fixed Costs” means an amount sufficient at all times to pay the principal of and the premium, if any, and interest on any Revenue Bonds, to provide reserves required therefor, to provide an adequate depreciation fund for the Waterworks System, to comply with the covenants of all Revenue Bond Ordinances, and to pay reasonable capital costs necessary to carry out the corporate purposes and powers of the Commission; except as any of the above are included in Operation and Maintenance Costs.

BB. “Full Water Requirements” means, (i) as it applies to calculating Bartlett’s

Capital Cost Recovery Charge, the amount of water necessary to meet the potable water requirements of all then current customers served by the Bartlett Unit System at the time Bartlett's Capital Cost Recovery Charge is being calculated, (ii) as it applies to the Bartlett Unit System for all other purposes of this Contract, the amount of water necessary from time to time to meet the potable water requirements of all then current customers served by the Bartlett Unit System, and (iii) as it applies to other Contract Customers of the Commission, such Contract Customers' full water requirements as defined in their respective contracts with the Commission.

CC. "Interest Period" means (i) initially, the period commencing on the first date on which Bartlett first becomes obligated to make payments under Subsection 7D of this Contract and ending on the next succeeding first day of May and (ii) thereafter, each period commencing on the last day of the next preceding Interest Period and ending on the next succeeding first day of May; provided, however, that any Interest Period that otherwise extends beyond February 24, 2024, shall end on February 24, 2024.

DD. "Lake Water" means potable, filtered water drawn from Lake Michigan.

EE. "Operation and Maintenance Costs" means amounts payable by the Commission under the Chicago Contract, except Underconsumption Costs, and all expenses incurred in the administration, operation, and maintenance of the Waterworks System and the accumulation of reserves related to payment of said costs. Operation and Maintenance Costs in any month shall be at least equal to the amount required to be deposited by the Commission in that month into the operation and maintenance funds or accounts created under all Revenue Bond Ordinances.

FF. “Original Capital Costs” means all costs paid by the Commission for property owned by the Commission, as April 30, 2016, without reduction for depreciation, including actual costs of construction, engineering, and capitalized interest on assets in service and under construction but excluding the cost of constructing the Charter Customer Facilities and financing costs other than interest capitalized in accordance with Generally Accepted Accounting Principles.

GG. “Original Revenue Bonds” means the Series 1987 Revenue Bonds, originally issued in the amount of \$200,000,000 pursuant to Ordinance No. 0-1-87 adopted January 15, 1987, and the Series 1993 Water Refunding Revenue Bonds, originally issued in the amount of \$182,755,000 pursuant to Ordinance No. 0-8-93 adopted April 8, 1993, and any other Revenue Bonds that may in the future be issued to refund or refinance all or any portion of the indebtedness represented by said Series 1987, 1993, 2003, and 2013 Revenue Bonds. As of the date of this Contract, all of the Original Revenue Bonds are fully paid and retired.

HH. “Other Bond Ordinances” means all of the Commission's ordinances and resolutions under which the Commission has or will authorize the issuance of, or issue, Other Bonds.

II. “Other Bonds” means all of the Commission's debt obligations that are not Revenue Bonds, whether in the form of bonds, notes, or other evidences of indebtedness, in whatever original principal amount, together with any such additional non-revenue obligations authorized by statute to be issued by the Commission from time to time and refunding obligations issued to refund other such obligations.

JJ. “Point of Delivery” means the point at which the Lake Water delivered to Bartlett pursuant to this Contract leaves the Commission's Waterworks System and enters the Bartlett

Unit System. The Point of Delivery shall be a point in the water main connecting the Commission's metering station to Bartlett's pressure adjusting station located downstream from the inside face of the outside wall or foundation of the Commission's metering station a distance of 10 feet or where such water main enters the outside face of the outside wall or foundation of Bartlett's pressure adjusting station, whichever is closer to the Commission's metering station.

KK. "Prime Rate" means the base corporate rate of interest then most recently announced by the largest commercial bank, measured in terms of total assets, located and doing banking business in the State of Illinois, which rate may or may not be said bank's lowest rate of interest charged by said bank for extensions of credit to debtors. The effective date of any change in the Prime Rate shall, for purposes hereof, be the effective date stated in the public announcement of said bank.

LL. "Rebates" means rebates formally declared as such by Commission Resolution as of the month prior to the month in which Bartlett first becomes obligated to make payments under Subsection 7D of this Contract. As of the date of this Contract, the Commission has formally declared \$106,326,287.00 in Rebates pursuant to Resolution Nos. R-19-94, R-21-95, R-15-96, R-24-97, R-18-98 and R-28-07.

MM. "Revenue Bond Ordinances" means all of the Commission's and resolutions under which the Commission has or will authorize the issuance of, or issue, Revenue Bonds.

NN. "Revenue Bonds" means all of the Commission's debt obligations, including the Original Revenue Bonds, that are payable from the revenues of the Waterworks System, whether in the form of bonds, notes, or other evidences of indebtedness, in whatever original principal amount, together with any such additional revenue obligations authorized by statute to be issued by the Commission from time to time and refunding revenue obligations issued to refund other

such obligations.

OO. “SCADA System” means the Supervisory Control and Data Acquisition System of the Commission that provides an integrated control, communication, and security system for the Waterworks System, including data processing, management, transfer, and exchange; central operation; system control and monitoring; and operator-machine interfacing.

PP. “Trustee” means a trustee provided in a Bond Ordinance.

QQ. “Underconsumer” means, for any given year, a Contract Customer of the Commission that takes less Lake Water in such year than such Contract Customer's Water Allocation times 365 times the Underconsumption Ratio for such year.

RR. “Underconsumption” means the amount by which the amount of Lake Water actually taken by a Contract Customer of the Commission is less than the Underconsumption Ratio times such Contract Customer's Water Allocation times 365.

SS. “Underconsumption Costs” means any amount that the Commission is obligated to pay under the Chicago Contract solely by reason of failure to accept delivery of the minimum quantity of Lake Water that the Commission is obligated to purchase under the Chicago Contract.

TT. “Underconsumption Ratio” means, for any given year, (i) the minimum amount of Lake Water required to be taken by the Commission under the Chicago Contract divided by (ii) the sum of the Water Allocations of all Contract Customers of the Commission times 365.

UU. “Water Allocation” means, as it applies to other Contract Customers of the Commission, such Contract Customers' water allocation as defined in their respective contracts with the Commission, and, as it applies to Bartlett, the sum of Bartlett's allocations and

allowable excesses from time to time of Lake Water for the Bartlett Unit System pursuant to the Level of Lake Michigan Act, as amended from time to time (See State of Illinois Department of Transportation, Division of Water Resources Decision on 1989 Allocation Review, Order No. LMO 89-2 and subsequent orders of the State of Illinois Department of Transportation, Division of Water Resources, or the successor to its responsibilities, the State of Illinois Department of Natural Resources, Office of Water Resources); and such other amounts of Lake Water as Bartlett may lawfully take for the Bartlett Unit System. At any time when the Full Water Requirements of the Bartlett Unit System shall exceed the Water Allocation for the Bartlett Unit System, then "Water Allocation" shall mean the Full Water Requirements of the Bartlett Unit System for all purposes of this Contract.

VV. "Waterworks System" means all the Commission's facilities, including land; easements; rights-of-way over lands and waters; pumping facilities, storage facilities, metering stations, and other facilities; mains; and pipelines acquired and used for the purposes of providing and transmitting Lake Water from the City of Chicago's water supply system to the Commission's customers. The Bartlett Unit System Connection Facilities are not part of the Waterworks System.

SECTION 3. WATER SUPPLY.

A. Agreement to Sell and Purchase. Subject to the provisions of this Contract, the Commission shall sell to Bartlett and Bartlett shall purchase from the Commission an amount of Lake Water necessary from time to time to serve the Bartlett Unit System's Full Water Requirements. The Commission's obligation to Bartlett to deliver Lake Water hereunder shall be limited, however, to a maximum annual amount equal to Bartlett's then current Water Allocation times 365 and to a maximum rate of Lake Water to the Bartlett Unit System in any one hour

equal to 1.7 times Bartlett's then current Water Allocation divided by 24.

B. Beginning of Obligations to Deliver and Receive Lake Water. Unless this Contract is sooner terminated by the Commission pursuant to Subsection 20C of this Contract, the Commission shall be obligated to deliver Lake Water to the Bartlett Unit System and Bartlett shall be obligated to receive at the Bartlett Unit System Lake Water delivered by the Commission immediately after completion of construction of the Connection Facilities and the water storage capacity required pursuant to Subsection 4B of this Contract; provided, however, that Bartlett shall have the right to receive Lake Water pursuant to this Contract prior to the completion of construction of the required storage capacity if such storage capacity has been substantially completed to the point where it is capable of serving its intended function or would be capable of serving its intended function except for the fact that painting or other finishing and restoration work are not complete.

C. Limits on Supply. The Commission shall use its best efforts to furnish Lake Water to Bartlett as hereinabove provided, but Bartlett acknowledges and agrees that the Commission's obligation hereunder is limited by:

1. The amount of Lake Water from time to time available to the Commission; and
2. Provisions in contracts between the Commission and its Charter Customers and other customers related to curtailment and other limits on supply of Lake Water; and
3. The capacity of the Waterworks System; and
4. Ordinary transmission loss, including standard metering error, between the Commission's source of supply and the Point of Delivery to the Bartlett Unit System; and
5. The other provisions of this Contract, including but not limited to Section 20.

D. Emergency or Maintenance Turn-Off. The Commission undertakes to use

reasonable care and diligence to provide a constant supply of Lake Water as herein provided for, but reserves the right at any time to turn off the flow of Lake Water in its mains for emergency and maintenance purposes. The Commission shall give notice not less than 48 hours in advance of any turn-off for maintenance purposes and it shall give such notice as is reasonable under the particular circumstances of any turn-off for emergency purposes.

E. Curtailment; Emergency Use of Other Sources. If it becomes necessary for the Commission to limit its delivery of Lake Water to its customers for any reason, Bartlett shall be entitled, to the extent possible, to receive during such period of curtailment a pro rata share of available Lake Water as determined by the ratio of (i) the Bartlett Unit System's total Lake Water use during the prior Fiscal Year for other than start-up purposes pursuant to Subsection 10I of this Contract to (ii) the sum of Lake Water use during the prior Fiscal Year of all of the Commission's customers entitled to Lake Water during such period of curtailment. Prior to the Commission's delivery of Lake Water to the Bartlett Unit System for a full Fiscal Year for other than start-up purposes pursuant to Subsection 10I of this Contract, Bartlett shall be entitled, to the extent possible, to receive during such period of curtailment a pro rata share of available Lake Water as determined by the ratio of the Bartlett Unit System's Full Water Requirements during the prior Fiscal Year to the sum of (i) Lake Water use during the prior Fiscal Year of all of the Commission's other customers entitled to Lake Water during such period of curtailment and (ii) the Bartlett Unit System's Full Water Requirements during the prior Fiscal Year. Bartlett, in cases of emergency or when the Commission for whatever reason is unable to meet the Bartlett Unit System's Full Water Requirements, may, subject to the terms, conditions, and limitations set forth in Subsection 9N of this Contract, serve its customers from any source;

provided, however, that Bartlett shall continue to pay all amounts due to the Commission hereunder during such period as if the Bartlett Unit System were receiving its Full Water Requirements from the Commission.

F. Water Quality. The Commission shall supply Bartlett with Lake Water of a quality commensurate to that furnished to the Commission's other Contract Customers, and meeting the requirements of any federal, State of Illinois, or local agency as shall have jurisdiction from time to time for the operation of public water supplies such as the Waterworks System. The Commission bears no responsibility for the contamination of Lake Water or deterioration of water quality occurring beyond the Point of Delivery to the Bartlett Unit System.

SECTION 4. DELIVERY; STORAGE; DISTRIBUTION; CONSERVATION.

A. Bartlett Unit System Connection Facilities. Bartlett shall receive its supply of Lake Water at the Bartlett Unit System Point of Delivery at pressures that will vary from time to time. Bartlett, at its own expense and pursuant to the schedule established in Section 10 of this Contract, shall site, design, construct, operate, maintain, and when necessary replace the Bartlett Unit System Connection Facilities, including a pressure adjusting station immediately downstream from the Point of Delivery. Initial design and construction plans and specifications for the Bartlett Unit System Connection Facilities, and any future modifications thereof, shall be submitted in advance of construction or modification to the Commission for review and approval, which approval shall not be unreasonably withheld.

B. Storage. Bartlett shall provide sufficient storage capacity within the Bartlett Unit System to store not less than two times the annual average daily water demand of the Bartlett

Unit System; provided, however, that said requirement shall be reduced by (i) the amount of operable shallow well capacity (stated in gallons per hour) maintained by Bartlett in the Bartlett Unit System up to a maximum of 10 percent of said requirement plus (ii) an amount equal to the storage capacity maintained by the Commission in its Waterworks System multiplied by a fraction, the numerator of which is the annual average daily water demand of the Bartlett Unit System and the denominator of which is the total annual average daily water demands of all Contract Customers. The calculation of said water storage capacity requirement for the Bartlett Unit System is provided in Exhibit C attached to this Contract. In accordance with said requirement, Bartlett, at its own expense and pursuant to the schedule established in Section 10 of this Contract, shall construct for the Bartlett Unit System at least the amount of water storage capacity shown on Exhibit C to this Contract as the "Minimum Additional Required Storage." Such water storage capacity shall be in addition to the amount of water storage capacity shown on Exhibit C to this Contract as the "Existing Storage" in the Bartlett Unit System. Bartlett shall properly maintain all such water storage capacity, including operable shallow well capacity, in a good and serviceable condition. If at any time Bartlett's water storage capacity in the Bartlett Unit System, including its allowances for operable shallow well capacity and Commission storage capacity as provided above, falls below 1.9 times the annual average daily water demand of the Bartlett Unit System, then Bartlett, within 24 months after such level of deficiency is reached, shall construct additional water storage capacity within the Bartlett Unit System of sufficient quantity to increase the total storage capacity of the Bartlett Unit System, including its allowances for operable shallow well capacity and Commission storage capacity as provided above, to not less than two times the annual average daily water demand of the Bartlett Unit System.

C. Metering of Shallow Wells. Bartlett shall furnish, install, and maintain a meter on each of its operable shallow wells. All such meters shall be of standard make and shall be subject to inspection and examination by any employee or agent of the Commission at all reasonable times. Bartlett shall calibrate all such meters at least once in each Fiscal Year. Bartlett shall notify the Commission of the time, date, and place of each calibration at least five days in advance thereof, and a representative of the Commission shall have the right to observe any adjustments made to such meters in case any adjustments shall be necessary. The Commission shall have the right to place any or all of such meters under seal at any time.

D. Surges and Back-Flows. Bartlett's operation of its pressure adjusting station shall not cause surges or back-flows into the Waterworks System, nor shall the operation of the Bartlett's pressure adjusting station cause the Waterworks System pressure to drop below 20 pounds per square inch. The Commission shall not be responsible for any damage to the Bartlett Unit System or the Bartlett Unit System Connection Facilities caused by the design, operation, or maintenance of the Connection Facilities.

E. Maintenance of System; Water Quality; Prevention of Waste. Bartlett shall operate the Bartlett Unit System and the Bartlett Unit System Connection Facilities in such a manner as at no time to place the Commission and the Waterworks System in jeopardy of failing to meet the regulations of any agency or governmental authority having jurisdiction over the Commission's operation of its Waterworks System. The Commission and Bartlett shall notify each other immediately of all emergency and other conditions which may directly or indirectly affect the Waterworks System, the Bartlett Unit System, the Connection Facilities, or the quantity or quality of the Lake Water received pursuant to this Contract.

SECTION 5. MEASURING EQUIPMENT.

A. Metering Station and Instrumentation. The Commission shall, pursuant to the timetable established in Section 10 of this Contract, furnish and install at the Point of Delivery a metering station containing the necessary equipment and devices of a type meeting the standards of the American Water Works Association for measuring properly the quantity of Lake Water delivered under this Contract, including all structures as the Commission shall deem necessary to house such equipment and devices. Such furnishing and installing of a metering station shall be done in substantial conformance with the preliminary plans therefor attached as Exhibit B-2 to this Contract, as such preliminary plans may be revised by mutual agreement of the Commission and Bartlett. The Commission shall own, operate, maintain, and replace such metering station and all equipment and structures related thereto.

The metering station shall be located at a site or sites selected and acquired by Bartlett, and title transferred to the Commission, free and clear of all liens, claims, encumbrances, and restrictions unless otherwise approved by the Commission in writing. Such site shall be subject to reasonable review and approval of the Commission, without charge to the Commission and pursuant to the timetable established in Section 10 of this Contract, shall grant to the Commission all necessary and insured easements for such site(s) and access thereto to the reasonable satisfaction of the Commission in a form similar to that attached as Exhibit D to this Contract and satisfactory to the Commission's attorneys. Bartlett also shall grant to the Commission all necessary and insured easements for the appropriate location and installation of antennas and appurtenant facilities for the Commission's SCADA System attributable to the

Bartlett Unit System on property owned by Bartlett or on property lying within the corporate limits of Bartlett, free and clear of all liens, claims, encumbrances, and restrictions unless otherwise approved by the Commission in writing. Such SCADA System antennas or facilities shall be installed on such easements in a manner that will reduce so far as reasonably possible any interference with the telemetry of the Bartlett Unit System.

Bartlett shall have access to the metering station for examination and inspection at reasonable times, but the reading for billing purposes, calibration, and adjustment of the equipment therein shall be done only by the employees or agents of the Commission.

B. Records. For the purpose of this Contract, the official record of readings of each meter at the metering station shall be the journal or other record book of the Commission in its office in which the records of the employees or agents of the Commission who take the readings are or may be transcribed. Upon written request of Bartlett, the Commission will give Bartlett a copy of such journal or record book, or permit Bartlett to have access thereto in the office of the Commission during regular business hours.

C. Calibration. At least once in each Fiscal Year, the Commission shall calibrate its meters measuring the Lake Water delivered to the Bartlett Unit System if requested in writing by Bartlett to do so, in the presence of a representative of Bartlett, and the Commission and Bartlett shall jointly observe any adjustments that are made to the meters in case any adjustments shall be necessary. If any check meters have been installed, then such check meters shall be calibrated at least once in each Fiscal Year by Bartlett in the presence of a representative of the Commission, and the Commission and Bartlett shall jointly observe any adjustments that are made to the meters in case any adjustments shall be necessary.

D. Check Meters. Bartlett, at its option and its own expense, may install and operate a check meter to check each meter installed by the Commission, but the measurement of Lake Water for purposes of this Contract shall be solely by the Commission's meters, except in the cases hereinafter specifically provided to the contrary. All check meters shall be of standard make and shall be subject to inspection and examination by any employee or agent of the Commission at all reasonable times. The calibration and adjustment of check meters shall be made only by Bartlett, except during any period when a check meter may be used under the provisions hereunder for measuring the amount of Lake Water delivered to Bartlett, in which case the calibration and adjustment of such check meter shall be made by the Commission with like effects as if such check meter had been furnished and installed by the Commission.

E. Meter Malfunctions. If the Commission or Bartlett at any time observes a variation between a meter and a check meter or any evidence of meter malfunction, such party shall promptly notify the other party, and the Commission and Bartlett shall then cooperate to procure an immediate calibration test and such adjustment, replacement, or other work necessary to return such meter to accuracy. The party who discovers such variation or malfunction shall give the other party notice not less than 48 hours prior to the time of any test of any meter (which tests shall be conducted during normal working hours) so that the other party may conveniently have a representative present. If such representative is not present after the required notification at the time set in such notice, calibration and adjustment may proceed in the absence of said representative notwithstanding any other provision of this Subsection 5E. If the percentage of inaccuracy of any meter is found to be in excess of two percent, registration thereof shall be corrected by agreement of the Commission and Bartlett based upon the best data available, for a period extending back to the time when such inaccuracy began if such time is

ascertainable, or for a period extending back one-half of the time elapsed since the last date of calibration (but in no event further back than a period of six months) if such time is not ascertainable.

If for any reason any meter is out of service or out of repair so that the amount of Lake Water delivered cannot be ascertained or computed from the reading thereof, then the Lake Water delivered during the period such meter is out of service or out of repair shall be deemed to be the registration of the check meter if one has been installed and is registering accurately, or, in the event that no check meter has been installed or the check meter is registering inaccurately, shall be estimated:

1. By correcting the error if the percentage of the error is ascertainable by calibration tests or mathematical calculations; or

2. If the error is not ascertainable by calibration tests or mathematical calculation, by estimating the quantity of delivery by considering deliveries during preceding periods under similar conditions when the meter or meters were registering accurately, adjusted for the addition of new customers to the Bartlett Unit System.

F. Removal of Metering Station and SCADA System Facilities. Within 90 days after the termination of this Contract without renewal, the Commission, at its own expense and in its discretion, may remove the metering station, including equipment, and the SCADA System antennas and appurtenant facilities from the property of Bartlett and release the perpetual easement therein. If the Commission fails to remove such station, equipment, and facilities, as aforesaid, Bartlett may take title to such station, equipment, and facilities.

SECTION 6. UNIT OF MEASUREMENT.

The unit of measurement for Lake Water delivered hereunder shall be gallons of water,

U.S. Standard Liquid Measure, and all measuring devices shall be so calibrated unless the Commission and Bartlett otherwise agree. Should it become necessary or desirable to use other units of measurement, the basis of conversion shall be that 7.48 gallons is equivalent to one cubic foot.

SECTION 7. PRICES AND TERMS OF PAYMENT.

A. Operation and Maintenance Costs Payment. Bartlett shall pay monthly to the Commission, at the time specified in Subsections 7G and 7M below, a share of the Commission's Operation and Maintenance Costs for each month, which shall be an amount equal to the then current price per 1,000 gallons for Operation and Maintenance Costs times the quantity of Lake Water divided by 1,000 delivered by the Waterworks System to the Bartlett Unit System for such month. At any time no Lake Water is being supplied through the Waterworks System to any Contract Customer, Bartlett's share of monthly Operation and Maintenance Costs for the Bartlett Unit System shall be that proportion of those costs which the Bartlett Unit System's Water Allocation bears to the total Water Allocations of all of the Commission's customers required to make Operation and Maintenance Costs payments during the same period.

B. Fixed Costs Payment. Subject to the single limitation on its obligation to pay Fixed Costs set forth in this Subsection 7B, Bartlett shall pay monthly to the Commission, at the time specified in Subsections 7G and 7M below, one-twelfth of the Bartlett Unit System's share of Fixed Costs for each Fiscal Year. However, as of the date of this Contract, the Fixed Costs are \$0 per month. For the purposes of this Contract, the Bartlett Unit System's share of Fixed Costs for each Fiscal Year shall be that proportion of Fixed Costs which the Bartlett Unit System's Full

Water Requirements for the two preceding calendar years prior to such Fiscal Year bears to the sum of the Full Water Requirements or Minimum Take or Pay Requirements, as applicable, of all of the Commission's Contract Customers for such two preceding calendar years who are not relieved from Fixed Costs payments pursuant to the terms of their contracts. Prior to the Commission's delivery of Lake Water to the Bartlett Unit System for two calendar years for other than start-up purposes pursuant to Subsection 10I of this Contract, the Bartlett Unit System's share of Fixed Costs shall be that portion of Fixed Costs which the Bartlett Unit System's Water Allocation bears to the total Water Allocations or the Full Water Requirements or Minimum Take or Pay Requirements, whichever is then applicable, of all of the Commission's Contract Customers who are not relieved from Fixed Costs payments pursuant to the terms of their contracts. Subject to the following single limitation, Bartlett's obligation to make all payments of Fixed Costs as required hereunder is unconditional and irrevocable, payable without setoff or counterclaim, and irrespective of whether Lake Water is ever furnished, made available, or delivered to the Bartlett Unit System, or whether the Waterworks System is completed, operable, or operating, and notwithstanding suspension, interruption, interference, reduction, or curtailment of the supply of Lake Water. Bartlett's obligation to pay Fixed Costs hereunder is subject to the single limitation that, if for any period of time, and only during such period of time, the Commission is in fact supplying the Full Water Requirements or Minimum Take or Pay Requirements, as applicable, to Contract Customers of the Commission, other than Bartlett, whose Full Water Requirements and Minimum Take or Pay Requirements are more than 85 percent of the sum of the Full Water Requirements or Minimum Take or Pay Requirements, as applicable, of all Contract Customers of the Commission, and during such time the Commission is unable to supply any Lake Water to the Bartlett Unit System, then Bartlett

shall have no obligation to pay Fixed Costs for the Bartlett Unit System. However, as of the date of this Contract, the Capital Recovery Cost Credit is \$0 because Fixed Costs are currently \$0.

C. Connection Facilities Cost Payment. Bartlett shall pay to the Commission its Connection Facilities Cost. Prior to the Commission's commencement of design of the Commission Connection Facilities pursuant to Subsection 10H of this Contract, Bartlett and the Commission shall enter into an Intergovernmental Agreement Concerning the Loan for Connection Facilities to Implement Water Service to the Village of Bartlett (the "Connection Facilities Cost IGA") substantially in the form attached hereto as Exhibit H for a loan in an amount not to exceed \$21,000,000 (the "Commitment Amount"), which is the current estimated sum of (i) all legal, engineering, consulting and administrative costs and expenses incurred or accrued in connection with the review and processing plans for the Bartlett Unit System Connection Facilities and in connection with the negotiation, preparation, consideration and review of this Contract and (ii) 125% of the Commission's estimate of the total cost of construction of the Commission Connection Facilities, including without limitation all legal, engineering, consulting and administrative costs and expenses. As of the date of this Contract, the Commission's estimate of the total cost of construction of the Commission Connection Facilities, including legal, engineering, consulting and administrative costs and expenses, is set forth in Exhibit B-2 attached to this Contract. The Commission may draw upon the Commitment Amount, without Bartlett's consent, but may only employ the proceeds to pay for the Connection Facilities Cost invoiced to, or otherwise documented by, the Commission and the Commission shall promptly notify Bartlett of any such withdrawals in compliance with the terms of the Connection Facilities Cost IGA. If at any time the Commission reasonably

determines that the funds remaining in the Commitment Amount are not, or may not be, sufficient to pay in full the remaining unpaid Connection Facilities Cost (the "Possible Shortfall"), then the Commission shall notify Bartlett of the Possible Shortfall, and if the parties do not agree within 30 days of said notice to increase the amount of the Commitment Amount to an amount reasonably determined by the Commission to be sufficient to pay in full the remaining unpaid Connection Facilities Cost, Bartlett shall within 10 days deposit the amount of the Possible Shortfall with the Commission. Failure to so deposit the amount of the Possible Shortfall within the 10-day time period shall be grounds for the Commission to retain a possessory lien upon any remaining balance of the Commitment Amount (as damages security) and terminate this Contract. Upon final payment of all amounts due under all executed contracts for the design, construction and inspection of the Commission Connection Facilities, the final loan amount under the Connection Facilities Cost IGA shall be set and the Commission shall not be obligated to lend any further funds to Bartlett. Bartlett's obligation to make the Connection Facilities Cost payments as required hereunder is unconditional and irrevocable, payable without setoff or counterclaim, and irrespective of whether Lake Water is ever furnished, made available, or delivered to Bartlett, or whether the Waterworks System is completed, operable, or operating, and notwithstanding suspension, interruption, interference, reduction, or curtailment of the supply of Lake Water.

D. Capital Cost Recovery Charge Payment. Bartlett shall pay monthly to the Commission, at the time specified in Subsections 7G and 7M below, an amount calculated by amortizing the Capital Cost Recovery Charge, in equal monthly installments of principal and interest, at a rate per annum equal to the Earned Interest Rate determined for each Interest Period plus one percent, over the life of the Charter Customer Contract remaining as of the month in

which Bartlett first becomes obligated to make such payment; provided, however, that such monthly installment may be adjusted by the Commission, on May 1 of each year thereafter, to ensure amortization of the then current amount of the Capital Cost Recovery Charge remaining unpaid, as of such May 1, over the life of the Charter Customer Contract then remaining, and to reflect any change in the Earned Interest Rate, as of such May 1. The method of calculating the Capital Cost Recovery Charge is illustrated in Exhibit E attached to this Contract. Bartlett's obligation to make all Capital Cost Recovery Charge payments as required hereunder is unconditional and irrevocable, payable without setoff or counterclaim, and irrespective of whether Lake Water is ever furnished, made available, or delivered to Bartlett, or whether the Waterworks System is completed, operable, or operating, and notwithstanding suspension, interruption, interference, reduction, or curtailment of the supply of Lake Water. However, the parties agree that if Bartlett pays the Commission the entire cost of the Capital Cost Recovery Charge upon execution of this Agreement, then Bartlett shall not be liable for the monthly Capital Cost Recovery Charge as provided in this Subsection 7D, but in lieu thereof Bartlett shall be obligated to pay the monthly payments due the Commission under the Intergovernmental Agreement Concerning Loan for Capital Cost Recovery Charge to the Village of Bartlett in form as set forth in Exhibit G (the "Capital Cost Recovery Charge IGA") that the parties will enter on even date herewith to fund and pay for the Capital Cost Recovery Charge Payment.

E. Underconsumption Costs Payment. If Bartlett is an Underconsumer at the Bartlett Unit System, then Bartlett shall pay, at the time specified in Subsections 7G and 7M below, its share of Underconsumption Costs as determined and assessed by the Commission

after notification of such costs by the City of Chicago. In such event, Bartlett's share of Underconsumption Costs for the Bartlett Unit System for a year shall be equal to the ratio of its Underconsumption to the aggregate Underconsumption of all Underconsumers for such year.

F. Default Shares. If any of the Commission's Contract Customers shall default in any payment to the Commission, or any part of any payment, including default shares, Bartlett agrees to pay to the Commission a share of the amount so in default, which share shall be in the same proportion as the Bartlett Unit System's share of Aggregate Costs for the month prior to the month of the default bears to the sum of the shares of Aggregate Costs in that month of all of the Commission's Contract Customers not in default and obligated to make payments with respect to the amount so in default.

Subject to Subsection 7M below, Bartlett's share of the amount so in default shall be due and payable 21 days after the Commission's written demand therefor. The demand shall include the Commission's calculations of the amount due by Bartlett hereunder. If and when the defaulting customer makes a payment to the Commission of a defaulted amount or interest thereon for which Bartlett made a payment to the Commission under this Subsection 7F, then the Commission will pay to Bartlett its proportionate share of such amount, including such interest.

G. Bills and Due Date. Except with respect to the payment of the Possible Shortfall required pursuant to Subsection 7C above and the payment of default shares pursuant to Subsection 7F above, the Commission shall notify Bartlett of the total amount due under this Contract for each month on or before the 10th day of the following month. Bartlett's costs for each month shall be due and payable, and must be received at the offices of the Commission, on

or before the 10th day of the month following the month of the Commission's notification or within 28 days after the date of notification, whichever is later.

H. Disputed Payments. If Bartlett desires to dispute any payment, or part thereof, due or reasonably claimed by the Commission to be due to be due under this Contract, Bartlett shall nevertheless pay the full amount of any such payment when due and include with such payment written notification to the Commission that charges are disputed, the grounds for dispute, and the amount in dispute. No adjustment or relief on account of any disputed charges shall be made unless disputed charges are the subject of such notice within the time herein specified, or within a reasonable period from the time Bartlett knew or should have known of the facts giving rise to the dispute.

Upon receipt of a notification of dispute, representatives of the Commission shall meet promptly with representatives of Bartlett to resolve such dispute.

If the Commission and Bartlett determine that all or a portion of the disputed payment should be refunded to Bartlett, then such sum shall be refunded with interest thereon at the rate established in Subsection 7I below from the date such disputed payment was made.

I. Interest on Overdue Payments. If Bartlett shall fail to make any payment required under this Contract, the Connection Facilities Cost IGA, or the Capital Cost Recovery Charge IGA to the Village of Bartlett on or before its due date, Bartlett shall be in default, and interest on the amount of such payment shall accrue to the extent permitted by law, and be compounded on a monthly basis, during the period of non-payment at the higher of:

1. the weighted average effective interest rate on all series of Bonds of the Commission any of which are then outstanding plus two percent; or

2. the Prime Rate plus five percent.

Such interest shall accrue from the date such payment becomes due until paid in full with interest as herein specified. If such payment is not made by Bartlett within 30 days after the date such payment becomes due, then the Commission, at its option and in its discretion, may reduce or discontinue delivery of Lake Water to the Bartlett Unit System until the amount due the Commission is paid in full with interest as herein specified. The Commission shall give notice to Bartlett not less than 20 days prior to the event of its intention to reduce or discontinue delivery of Lake Water in accordance with this Subsection 7I and shall provide Bartlett an opportunity for a hearing before the Commission prior to any reduction or discontinuance. If the Commission reduces or discontinues the delivery of Lake Water under such circumstances, Bartlett shall nevertheless continue to be liable to pay all charges provided for herein as if the Bartlett Unit System were receiving its Full Water Requirements from the Commission. The rights specified in this Subsection 7I shall be in addition to all other rights and remedies available to the Commission under this Contract, at law, or in equity for breach of any of the provisions of this Contract.

J. Security Deposit. If Bartlett is at any time in default on any payment due under this Contract, the Connection Facilities Cost IGA or the Original Capital Costs IGA, and the default is not cured within 30 days after the due date of the defaulted payment, then the Commission, at its option and in its discretion, may require Bartlett, as a further obligation under this Contract, to deposit in a separate account in the Commission's name a sum of money as security for the payment of Bartlett's obligations hereunder of a reasonable amount determined by the Commission. Bartlett's compliance with the Commission's demand for such a security deposit

shall be a condition precedent to the curing of such Bartlett default and the restoration of the Lake Water service to the Bartlett Unit System if such Lake Water service has been reduced or discontinued by reason of such default. The security deposit or any part thereof may be applied, at the Commission's option and in its discretion, to any subsequent default by Bartlett in any payments due under this Contract, the Connection Facilities Cost IGA or the Original Capital Costs IGA. If so applied, Bartlett shall provide funds within 10 days to restore the security deposit to the amount required by the Commission. At the earliest of the end of the term of this Contract, or a term of two years after the curing of the most recent default by Bartlett, or such earlier time that the Commission at its option and in its discretion may determine, any security deposit shall be returned to Bartlett if Bartlett has performed all its obligations under this Contract, the Connection Facilities Cost IGA or the Capital Cost Recovery Charge IGA. Bartlett shall not be entitled to receive any interest on any security deposit.

K. Prepayments. Subject to the limitations of this paragraph, Bartlett may (i) at any time, and from time to time, before Bartlett first becomes obligated to make payments of Operation and Maintenance Costs pursuant to Subsection 7M below, and (ii) no more frequently than once in any given year thereafter, at any time during the month of December, prepay, in whole or in part, the Connection Facilities Cost and the Capital Cost Recovery Charge Amount due pursuant to this Contract, without premium or penalty, upon at least one business day's irrevocable notice to the Commission, specifying the date and amount of prepayment. If such notice is given, Bartlett shall make such prepayment and the payment amount specified in such notice shall be due and payable on the date specified therein. The proceeds of any such prepayment shall be applied by the Commission first, to the payment of accrued and unpaid

interest, if any, on the Connection Facilities Cost accruing after the date specified in Subsection 7M below; second, to the payment of the unpaid principal balance of the Connection Facilities Cost; third, to the payment of accrued and unpaid interest, if any, on the Capital Cost Recovery Charge Amount accruing after the date specified in Subsection 7M below; and fourth, to the payment of the unpaid principal balance of the Capital Cost Recovery Charge Amount; provided, however, that Bartlett shall not be entitled to make any such prepayment pursuant to this paragraph if Bartlett's Base Rate during the Fiscal Year next following the date of such payment would be, as estimated by the Commission, less than the Average Charter Customer Rate Per 1,000 Gallons. For purposes of calculating Bartlett's Base Rate, any such prepayment shall be deemed to have been paid effective as of the 30th day of April next following the date of such payment or the 30th day of April next following the month in which Bartlett first becomes obligated to make such Connection Facilities Cost payments and Capital Cost Recovery Charge Amount payments, whichever is later. Bartlett shall not be entitled to, nor receive any credit for, interest on any such prepayment.

Notwithstanding anything to the contrary contained herein, in the event the Bartlett Unit System has not been constructed, installed, and completed, to a point where it is capable of serving its intended function at the time Bartlett first becomes obligated to make payments of Operation and Maintenance Costs pursuant to Subsection 7M below, then the Commission may, in its sole and absolute discretion, declare the principal amount of the Connection Facilities Cost remaining unpaid, in whole or in part, the principal amount of the Capital Cost Recovery Charge remaining unpaid, in whole or in part, or both of such remaining unpaid costs, in whole or in part, due and payable within 30 days following the date of such

declaration, together with accrued and unpaid interest as herein specified on such declared due amounts to the date paid, unless the Commission shall have exercised its right to terminate this Contract pursuant to Subsection 20C of this Contract. The rights specified in this paragraph shall be in addition to all other rights and remedies available to the Commission under this Contract, at law, or in equity for breach of any of the provisions of this Contract.

L. Enforcement of Provisions Hereof By Other Customers. Bartlett acknowledges that its obligation to make payments pursuant to the terms of this Section 7 is of benefit to the Commission's Charter Customers, Bondholders and any Trustee. Accordingly, Bartlett agrees that, in addition to the Commission, Bondholders, a Trustee or other parties allowed by law are entitled to enforce the provisions of this Contract. Further, any three or more of the Commission's Charter Customers acting together may enforce the provisions of this Section 7, but only if the Commission has not acted to enforce such provisions within 90 days after any failure by Bartlett to make a payment hereunder.

M. Beginning of Obligation to Pay. Notwithstanding any other provision of this Contract, the obligation to make any and all payments under this Contract, except only payments of Operation and Maintenance Costs pursuant to Subsection 7A above and payment of any Possible Shortfall required pursuant to Subsection 7C above, shall begin on the Commission's first regular billing cycle after the earlier to occur of (i) the first delivery of Lake Water to the Bartlett Unit System or any portion thereof or (ii) 12 months following completion of construction of the Commission Connection Facilities, other than the SCADA System facilities, to the point where they are capable of serving their intended function or would be capable of serving their intended function except for the fact that the Bartlett Unit System Connection

Facilities are not complete. The obligation to make payments of Operation and Maintenance Costs pursuant to Subsection 7A above shall begin on the Commission's first regular billing cycle after the earlier to occur of (i) the first delivery of Lake Water to the Bartlett Unit System or any portion thereof or (ii) completion of construction of the Commission Connection Facilities, other than the SCADA System Facilities, to the point where they are capable of serving their intended function or would be capable of serving their intended function except for the fact that the Bartlett Unit System Connection Facilities are not complete. At any time prior to the first delivery of Lake Water to the Bartlett Unit System when Bartlett is obligated to make payments pursuant to this Subsection 7M, such payments shall be based on the Full Water Requirements of the Bartlett Unit System.

N. Provisions in Lieu of Water Allocation. At any time before the State of Illinois Department of Natural Resources, Office of Water Resources, first grants a Water Allocation to Bartlett for the Bartlett Unit System when reference to a Water Allocation is necessary to give meaning to any term of this Contract, the Water Allocation for the Bartlett Unit System shall be deemed to be 3.151 million gallons per day. At any time after the State of Illinois Department of Natural Resources, Office of Water Resources, first grants a Water Allocation to Bartlett for the Bartlett Unit System that no Water Allocation is in effect for the Bartlett Unit System and reference to a Water Allocation is necessary to give meaning to any term of this Contract, the Water Allocation for the Bartlett Unit System shall be deemed to be the Bartlett Unit System's Full Water Requirements for the then most recently completed calendar year divided by 365.

SECTION 8. SPECIAL CONDITIONS AND COVENANTS.

A. Construction of the Commission Connection Facilities; No Delay Damages; Supply of Lake Water. The Commission will make a diligent effort to have the Commission

Connection Facilities completed to the Point of Delivery so as to furnish Lake Water to the Bartlett Unit System by the date specified in Subsection 10H of this Contract, but the Commission does not in any way guaranty delivery by such date.

Bartlett acknowledges and agrees that the Commission shall not be liable to Bartlett for any damages occasioned by or in any way related to delay in the delivery of Lake Water to the Bartlett Unit System, and all payments from Bartlett provided for under this Contract shall remain due and payable in accordance with the terms of this Contract notwithstanding any such delay.

After Lake Water is first tendered for delivery to the Bartlett Unit System at the Point of Delivery for other than start-up purposes pursuant to Subsection 10I of this Contract, the Commission, subject to the other terms and conditions of this Contract, shall use its best efforts to continually hold itself ready, willing, and able to supply Lake Water to the Bartlett Unit System at such Point of Delivery. The Commission also shall use its best efforts, consistent with its prior obligations and legal obligations to its Charter Customers and its other customers and consistent with the fair and equitable treatment of all of its Contract Customers, to supply the Bartlett Unit System with such additional amounts of Lake Water as from time to time may be allocated to the Bartlett Unit System over and above the Bartlett Unit System's present Water Allocation; provided, however, that the Commission does not in any way guaranty a supply of such additional amounts.

B. Lake Water Only; Costs. Except with the prior approval of Bartlett, the Commission shall not deliver any water to the Bartlett Unit System other than Lake Water. Except for Lake Water supplied for start-up purposes pursuant to Subsection 10I of this

Contract, costs for Lake Water charged to Bartlett by the Commission pursuant to this Contract shall include only the costs set forth in Section 7 of this Contract.

C. Title to Lake Water. Title to all Lake Water supplied hereunder shall remain in the Commission to the Point of Delivery and thereupon shall pass to Bartlett.

D. Emergency Supply. Subject to the terms, conditions, and limitations set forth in Subsection 9N of this Contract, Bartlett may contract for a temporary supply of water in case of an emergency from any unit of local government or any other entity. Bartlett shall notify the Commission and shall promptly provide the Commission with copies of all such contracts.

E. Covenants to Be Set Out in Bond Ordinance. Bartlett acknowledges the existence, and its understanding of the provisions, of certain Bond Ordinances pursuant to which the Commission has previously issued its Bonds. Bartlett further acknowledges and agrees that said Bond Ordinances grant to Bondholders certain rights to enforce certain duties of the Commission and its customers, including those with respect to the making of rates and charges and the collection of revenues, and that such Bondholder rights may be included in any subsequent Bond Ordinances.

F. Payments Hereunder an Operation Expense of Bartlett Unit System. Bartlett agrees that, to the fullest extent permitted by law or contract, all payments to be made by Bartlett pursuant to this Contract shall constitute operating expenses of the Bartlett Unit System as to any and all revenue bonds of Bartlett which are supported in whole or in part by a pledge of the revenues of the Bartlett Unit System, with the effect that Bartlett's obligation to make payments from its water revenues under this Contract has priority over its obligation to make payments of the principal and of the premium, if any, and interest on any such bonds which are or will be

supported in whole or in part by a pledge of any Bartlett Unit System revenues. Bartlett shall make all budgetary, emergency, and other provisions and appropriations necessary to provide for and authorize the prompt payment to the Commission of all rates and charges under this Contract. The obligations of Bartlett under this Contract are further payable from all other accounts of the Bartlett Unit System in which there are lawful available funds. In any revenue bond or indenture hereafter issued by Bartlett, the priority of lien established pursuant to this Contract shall be expressly provided and set forth in said bond ordinances or resolutions. Notwithstanding the foregoing, however, Bartlett's obligations under the IEPA Loans referenced in Subsection 9D to be secured in whole or in part by a pledge of Bartlett Unit System revenues to the IEPA shall have priority of lien over Bartlett's obligation to make payment from its water revenues under this Contract.

SECTION 9. ADDITIONAL BARTLETT COVENANTS.

A. Maintenance of Corporate Existence. Bartlett agrees that during the term of this Contract it will maintain its municipal corporate existence, it will continue to be a municipal corporation in good standing in the State of Illinois, it will not dissolve or otherwise dispose of all or substantially all of the assets of the Bartlett Unit System.

B. Maintenance and Operation of Bartlett Unit System. Bartlett shall own and maintain the Bartlett Unit System and the Bartlett Unit System Connection Facilities, and all improvements and extensions of the Bartlett Unit System and the Bartlett Unit System Connection Facilities, in good repair and working order, will operate the Bartlett Unit System and the Bartlett Unit System Connection Facilities efficiently, and will punctually perform all duties with respect to the Bartlett Unit System and the Bartlett Unit System Connection

Facilities as may be required by this Contract, and by the Constitution and laws of the State of Illinois and all other applicable laws. In the event of any deterioration, injury, damage, or other loss to the Bartlett Unit System or the Bartlett Unit System Connection Facilities affecting Bartlett's ability to deliver water to any of Bartlett's customers, Bartlett shall promptly restore the Bartlett Unit System or the Bartlett Unit System Connection Facilities and their capacity to so deliver water.

C. Rate Covenant. Bartlett shall take all necessary actions to establish, maintain, revise as necessary, and collect rates and charges for customers of the Bartlett Unit System as shall be required from time to time to produce revenues at least sufficient:

1. To pay all amounts due under this Contract, the Connection Facilities Cost IGA, the Capital Cost Recovery Charge IGA and the IEPA Loans referenced herein, and to pay all other costs of operation and maintenance of the Bartlett Unit System and the Bartlett Unit System Connection Facilities; and

2. To provide an adequate depreciation fund for the Bartlett Unit System and the Bartlett Unit System Connection Facilities; and

3. To make all deposits in all funds and accounts required by the terms of resolutions or ordinances authorizing any obligation of Bartlett payable from the revenues of the Bartlett Unit System; and

4. To pay the principal of and the premium, if any, and interest on all obligations of Bartlett payable from the revenues of the Bartlett Unit System including, but not limited to, its obligations under the Connection Facilities Cost IGA, the Capital Cost Recovery Charge IGA, and to repay the IEPA Loans referenced in Subsection 9D.

D. Future Subordination of Obligations. Any ordinance, resolution, motion, or other

action of Bartlett which authorizes the issuance after the date of this Contract of any obligation of Bartlett to be paid from the revenues of the Bartlett Unit System will expressly provide that revenues of said System may be used to pay principal of, and the premium, if any, and the interest on such obligations only to the extent that those revenues exceed the amounts required to pay the operation and maintenance expenses of said System including, expressly, all amounts payable from time to time under this Contract, except for any present or future ordinance, resolution, motion or other action of Bartlett which authorizes, or has authorized, it to borrow funds from and enter a loan agreement with the Illinois Environmental Protection Agency (the "IEPA Loans") which may provide for the collection, segregation, distribution and/or pledge of revenues of the Bartlett Unit System which shall be the only obligation with preference of priority over Bartlett's obligation to the Commission hereunder.

E. General Covenant to Operate Properly. From time to time, Bartlett shall take all steps reasonably necessary so that the Bartlett Unit System and the Bartlett Unit System Connection Facilities may at all times be operated properly and advantageously.

F. Accounting and Audit. Bartlett shall make and keep proper books and accounts (separate and apart from all other records and accounts of Bartlett) in which complete entries shall be made of all transactions relating to the Bartlett Unit System, and, within 180 days after the close of each of its fiscal years occurring during the term of this Contract, Bartlett shall cause the books and accounts of the Bartlett Unit System to be audited annually by independent certified public accountants, showing the receipts and disbursements on account of the Bartlett Unit System.

G. Maintain Ownership of Bartlett Unit System. Bartlett shall construct to

completion and thereafter continue to own and possess the Bartlett Unit System and, within the exercise of reasonable business judgment and in a manner so as not to cause a default hereunder, shall dispose of property which is part of said System only to the extent that such property is no longer useful or profitable in the operations of said System.

H. Insurance. Bartlett shall carry insurance or maintain self-insurance with respect to the Bartlett Unit System and the Bartlett Unit System Connection Facilities of the kinds and in the amounts that are customarily carried or maintained by parties operating similar properties, including, without limiting the generality of the foregoing, fire and other casualty and liability insurance or protection. All moneys received for loss under the insurance policies or on deposit as self-insurance reserves shall be used in making good the loss or damage in respect of which they were paid, whether by repairing the property damaged or replacing the property destroyed, and provision for making good such loss or damage or replacing the property destroyed shall be made within a reasonable time from date of loss. The proceeds derived from any and all policies or available from self-insurance reserves for public liability losses shall be used in paying or reimbursing any accounts from which payments for settlements, judgments, or expenses were advanced.

I. Continue to Serve. Bartlett shall use its best efforts to continue serving all customers of the Bartlett Unit System within its territorial limits that are intended to be served by the Bartlett Unit System as of the date of this Contract.

J. Maintain Water Allocation. Bartlett shall use its best efforts to obtain or retain, from time to time, a Water Allocation for the Bartlett Unit System at least equal to, but not in excess of two times, the Bartlett Unit System's Full Water Requirements from time to time.

K. Release and Indemnification. To the fullest extent permitted by law, Bartlett

hereby releases the Commission from, agrees that the Commission shall not be liable for, and agrees to indemnify and hold the Commission harmless from: (1) any liabilities for any loss or damage to property or any injury to, or death of, any person that may be occasioned by or related to any cause whatsoever pertaining to the construction, installation, removal, relocation, replacement, extension, improvement, maintenance, or operation of the Bartlett Unit System or the Connection Facilities or (2) any liabilities, losses, or damages, or claims therefor, arising out of the failure, or claimed failure, of Bartlett to comply with its covenants or obligations contained in this Contract, including, in each such case, any attorneys' fees. Bartlett agrees to indemnify and hold the Commission harmless to the fullest extent permitted by law from any losses, costs, charges, expenses (including attorneys' fees), judgments, and liabilities incurred by the Commission in connection with any action, suit, or proceeding instituted or threatened by any third party in connection with this Contract. If any such claim is asserted, the Commission shall give prompt notice to Bartlett and Bartlett, if requested by the Commission, shall assume the defense thereof, it being understood, however, that Bartlett shall not settle or consent to the settlement of any such claim without the written consent of the Commission.

L. Combining or Separating System Accounts. Bartlett shall not combine its waterworks system with its sewerage system or separate its combined waterworks and sewerage system into separate systems unless:

1. Bartlett shall have provided the Commission with written evidence, satisfactory to the Commission, that the proposed combination or separation will not materially or adversely affect Bartlett's ability to comply with all of the terms, conditions, and covenants of this Contract; and
2. The Commission shall have approved such combination or separation in writing.

M. Rate of Withdrawal. Bartlett will take Lake Water at the most uniform and continuous rate of withdrawal practical.

N. Emergency Interconnections. No emergency interconnection between the Bartlett Unit System and a water distribution system owned and operated by another Contract Customer ("Emergency Interconnection") shall be constructed, operated, or maintained except in accordance with the following terms, conditions, and limitations:

- (i) The other Contract Customer and Bartlett shall submit to the Commission, for its review and approval, within 60 days following the construction of the Emergency Interconnection or, if the Emergency Interconnection was constructed prior to the execution of this Contract, within 60 days following the execution of this Contract, a report detailing the exact location of the Emergency Interconnection, the manner in which the Emergency Interconnection has been and will be operated and maintained, and the terms of any written or oral agreement for the operation and maintenance of the Emergency Interconnection. Such report shall include as-built drawings of the Emergency Interconnection and exact duplicates of any written agreement for the operation and maintenance of the Emergency Interconnection. The Emergency Interconnection shall not be operated unless and until the Commission shall have approved such report and the Commission shall have received and approved the written agreements required pursuant to clauses (ix) and (xii) of this Subsection 9N. No approval of such report shall be withheld unless the Emergency Interconnection, or any agreement for the operation and maintenance of the Emergency Interconnection, violate the Charter Customer Contract, this Contract, the Chicago Contract, or applicable laws or regulations, or pose a threat to the Commission or its Waterworks System.
- (ii) The Emergency Interconnection shall be utilized only under emergency conditions unless otherwise approved, in writing, by the Commission. An emergency condition shall be defined to mean the inability to provide average day flow demands to regular, non-emergency supply customers during a limited period of time due to conditions beyond the control of the party requesting Lake Water. An emergency condition shall not mean any limitation imposed by the Commission on the supply of Lake Water to the other Contract Customer or Bartlett specifically related to the other Contract Customer or Bartlett pursuant to Section 3 of this Contract or any similar provision of any other water purchase and sale contract, as the case may be, and the Emergency Interconnection shall not be utilized to circumvent the provisions of any agreement approved by the Commission for the Alternate Delivery of Lake Water.
- (iii) The Emergency Interconnection shall be maintained in such a manner as at no time to

place or threaten to place the Commission or its Waterworks System in jeopardy of failing to meet the terms of the Charter Customer Contract, this Contract, the Chicago Contract, or the regulations of any agency or governmental authority having jurisdiction over the of a public water supply.

- (iv) The party experiencing the emergency condition shall give telephonic notice to the Commission and to the other party of the emergency condition, the expected duration of the emergency condition, and the amount of Lake Water needed, prior to the operation of the Emergency Interconnection. The Emergency Interconnection shall not be operated unless and until the party experiencing the emergency condition shall have given said notice to the Commission.
- (v) The party receiving Lake Water through the Emergency Interconnection shall provide daily telephonic notice to the Commission and the party delivering Lake Water for so long as the emergency deliveries continue, and shall provide telephonic notice to the Commission before final shut-off of the emergency flow of Lake Water through the Emergency Interconnection for each such emergency condition.
- (vi) The other Contract Customer and Bartlett shall keep a joint record of the amount of Lake Water delivered through the Emergency Interconnection, a copy of which shall be provided to the Commission within five days following termination of the use of the Emergency Interconnection for each such emergency condition and, in any case, every five days where the Emergency Interconnection is in continuous for more five days.
- (vii) The amount of Lake Water delivered to the other Contract Customer's water distribution system or to the Bartlett Unit System through the Emergency Interconnection, as the case may be, shall be paid to the Commission directly by the party receiving Lake Water through the Emergency Interconnection at the rates applicable pursuant to, and in accordance with, that party's water purchase and sale contract with the Commission. In case of service curtailment, the other Contract Customer's flow of water through the Emergency Interconnection shall be considered as a portion of the other Contract Customer's allocation from the Commission. In case of service curtailment, Bartlett's flow of water through the Emergency Interconnection shall be considered as a portion of Bartlett's allocation from the Commission.
- (viii) The Commission shall have the right to inspect the Emergency Interconnection, and its operation and maintenance. The Commission shall have the right to install seals or such other devices as the Commission, in its sole and absolute discretion, determines are necessary to determine the operation of the Emergency Interconnection, and all equipment required to be installed to allow the installation of the seals or such other devices shall be installed at Bartlett's sole cost and expense.
- (ix) The Commission shall bear no responsibility for, and the other Contract Customer and Bartlett shall, in writing, release the Commission from, and agree, to the fullest extent permitted by law, that the Commission shall not be liable for, and agree to indemnify

and hold the Commission harmless from, any claims, damages, liabilities, and litigation that may be occasioned by, connected with, or in any way related to the construction, operation, and maintenance of the Emergency Interconnection. The other Contract Customer and Bartlett shall agree, in writing, to pay all fees, costs, and expenses, including legal and administrative fees, costs, and expenses, incurred by the Commission in defending itself with regard to any and all of the matters mentioned in this Subsection 9N.

- (x) The operation and maintenance of the Emergency Interconnection shall comply in all other respects with the Water Commission Act of 1985, the Charter Customer Contract, this Contract, the Chicago Contract, and Resolution No. R-13-90 and the requirements of the Commission thereunder.
- (xi) Notwithstanding anything to the contrary contained in any written or oral agreement for the operation and maintenance of the Emergency Interconnection, the Emergency Interconnection shall be operated and maintained only in accordance with this Subsection 9N and such additional or other terms, conditions, and limitations as the Commission shall impose pursuant to any policy established by the Commission with respect to emergency interconnections. No such agreement shall be amended, modified, or otherwise changed except upon the prior written approval of the Commission.
- (xii) The Commission reserves the right to order all use of the Emergency Interconnection to be discontinued, and the other Contract Customer and Bartlett shall agree, in writing, to discontinue such use, at any time the terms, conditions, and limitations of this Subsection 9N and any such additional or other terms, conditions and limitations imposed by the Commission pursuant to any policy established by the Commission with respect to emergency interconnections are not satisfied.

No emergency interconnection between the Bartlett Unit System and a water distribution system owned and operated by any other person, firm, or organization shall be constructed, operated, or maintained except upon the prior written approval of Commission.

SECTION 10. SCHEDULE FOR COMPLETION OF VARIOUS FACILITIES.

A. Plans and Specifications for Bartlett Unit System Connection Facilities. Bartlett shall prepare, and submit to the Commission for its review and approval, complete detailed plans, specifications, and construction contract documents for the Bartlett Unit System Connection Facilities not later than 365 days after the effective date of this Contract. The

Commission shall provide its comments and revisions to Bartlett within 28 days after receipt of such documents. Bartlett shall incorporate all required changes to such documents within 28 days after receipt of the Commission's comments and revisions.

B. IEPA and Other Approvals For Bartlett Unit System Connection Facilities.

Bartlett shall, within 35 days after receipt of the Commission's comments and revisions pursuant to Subsection 10A above, submit such finally revised documents for approval and permitting to the Illinois Environmental Protection Agency (the "IEPA") and every other federal, state, or local governmental body having jurisdiction over any element of the Bartlett Unit System Connection Facilities, and shall diligently pursue each such approval and permit until it is secured.

C. Commencement of Construction of Bartlett Unit System Connection Facilities.

Bartlett shall cause construction of the Bartlett Unit System Connection Facilities to be commenced within 425 days after the effective date of this Contract or 28 days after receipt of the last approval from any governmental body required as a condition precedent to construction of the Bartlett Unit System Connection Facilities, whichever is later. Bartlett shall cause construction to be completed within 500 days after commencement.

D. Plans and Specifications for Water Storage Facilities. Bartlett shall prepare, and submit to the Commission for its review approval, complete detailed plans, specifications, and construction contract documents for the water storage facilities required to be built by Bartlett pursuant to Subsection 4B of this Contract within 425 days after the effective date of this Contract. The Commission shall provide its comments and revisions to Bartlett within 28 days after receipt of such documents. Bartlett shall incorporate all required changes to such documents within 28 days after receipt of the Commission's comments and revisions.

E. IEPA and Other Approvals for Water Storage Facilities. Bartlett shall, within 35 days after receipt of the Commission's comments and revisions pursuant to Subsection 10D above, submit such finally revised documents for approval and permitting to the IEPA and every other federal, state, or local government body having jurisdiction over any element of the water storage facilities, and shall diligently pursue such approval and permit until it is secured.

F. Commencement of Construction of Water Storage Facilities. Bartlett shall cause construction of the water storage facilities to be commenced within 425 days after the effective date of this Contract or 28 days after receipt of the last approval from any governmental body required as a condition precedent to construction of the water storage facilities, whichever is later. Bartlett shall cause construction to be completed within 500 days after commencement.

G. Transfer of Property Rights. Bartlett shall grant to the Commission all necessary easements for the Commission metering station and other facilities to be constructed pursuant to Subsection 5A of this Contract within 425 days after the effective date of this Contract. Bartlett shall, immediately upon execution of this Contract, commence all actions necessary to acquire all property rights not already owned by it necessary to fulfill the requirements of Subsection 5A of this Contract and this Subsection 10G.

H. Commencement of Construction of Commission Connection Facilities. The Commission shall cause design of the Commission Connection Facilities to be commenced within 28 days after receipt from Bartlett of the preliminary plans and specifications for the Bartlett Unit System Connection Facilities satisfactory to the Commission or 28 days after acquisition of all rights of way and other property by Bartlett acquired for the installation of the Commission Connection Facilities, whichever is later. The Commission shall cause construction

to be completed within 425 days after commencement of design as herein required or 300 days after receipt of the last approval from any governmental body required as a condition precedent to construction of the Commission Connection Facilities, whichever is later. Bartlett acknowledges and agrees, however, that the Commission may, in the exercise of its sole and absolute discretion, accelerate commencement of the design and construction of the Commission Connection Facilities, or completion of construction thereof, without in any way affecting the obligations of Bartlett under this Contract, including without limitation Bartlett's payment obligations.

I. Delivery of Water for Start-Up Purposes. The Commission shall use its best efforts, consistent with its prior obligations and legal obligations to its Charter Customers and its other customers and consistent with the fair and equitable treatment of all of its Contract Customers, to supply Bartlett with Lake Water for pressure testing, disinfecting, and flushing the Bartlett Unit System, the Bartlett Unit System Connection Facilities, and the required water storage facilities prior to completion of construction if (i) construction of the Bartlett Unit System, the Bartlett Unit System Connection Facilities, and the required water storage facilities is proceeding in the regular course to completion; (ii) the construction of the Commission Connection Facilities has been completed, other than the SCADA System facilities, to the point where the Commission Connection facilities are capable of serving their intended function or would be capable of serving their intended function except for the fact that the Bartlett Unit System or the Bartlett Unit System Connection Facilities are not complete; (iii) such Lake Water is utilized by Bartlett solely for purposes of pressure testing, disinfecting, and flushing the Bartlett Unit System, the Bartlett Unit System Connection Facilities, or the required water storage facilities; and (iv) Bartlett pays to the Commission, at the time specified in Subsection

7H of this Contract, an amount equal to the then current price per 1,000 gallons for Operation and Maintenance Costs times the amount of water, stated in thousands of gallons, actually received from the Commission for such purposes until such time as Bartlett first becomes obligated to make payments of Operation and Maintenance Costs pursuant to Subsections 7A and 7M of this Contract.

J. Illustrative Schedule of Events. An “Illustrative Schedule of Events” depicting, on the basis of assumptions concerning the length of time necessary to secure various governmental approvals, the sequence of work pursuant to this Section 10 is attached to this Contract as Exhibit F. In the event of any conflict or inconsistency between the provisions of Exhibit F and the provisions of this Section 10, the provisions of this Section 10 shall control.

SECTION 11. ASSIGNABILITY.

Bartlett shall not assign or transfer this Contract or any rights or interests herein without the advance written consent of the Commission.

The right to receive all payments that are required to be made by Bartlett to the Commission in accordance with the provisions of this Contract may be assigned by the Commission to any Trustee as provided in any Bond Ordinance to secure the payment of the principal of and the premium, if any, and interest on the Bonds as those amounts come due, subject to the application of those payments as may be provided in any Bond Ordinance. Bartlett, upon notice of assignment to any such Trustee, shall make all payments directly to such Trustee. Further, the rights of the Commission to enforce the provisions of this Contract may be assigned to any such Trustee and, in such event, such Trustee shall have the right to enforce this Contract at law or in equity with or without the further consent or participation of

the Commission. The Commission also may retain the right to enforce this Contract.

SECTION 12. FORCE MAJEURE.

If by reason of a force majeure event, either party to this Contract shall be rendered unable wholly or in part to carry out its obligation under this Contract, then if such party shall give notice and full particulars of such force majeure event in writing to the other party within a reasonable time after occurrence of the event or cause relied on, the obligation of the party giving such notice, so far as it is affected by such force majeure event, shall be suspended during the continuance of the inability then claimed, but for no longer period, and any such party shall endeavor to remove or overcome such inability with all reasonable dispatch. The term "force majeure event" as employed herein shall mean acts of God; strikes, lockouts, or other industrial disturbances; acts of a public enemy; orders of any kind of the Government of the United States, of the State of Illinois, or of any civil or military authority; insurrections; riots; epidemics; landslides; lightning; earthquakes; fires; hurricanes; storms; floods; washouts; droughts; arrests; restraints of government and people; civil disturbances; explosions, breakage, or accidents to machinery, pipelines, canals, or tunnels; partial or entire failure of water supply; and inability on the part of the Commission to deliver Lake Water hereunder, or of Bartlett to receive Lake Water hereunder, on account of any other causes not reasonably within the control or ability to cure of the party claiming such inability. The settlement of strikes and lockouts shall be entirely within the discretion of the party having the difficulty and the above requirement that any force majeure event shall be remedied with all reasonable dispatch shall not require the settlement of strikes and lockouts by acceding to the demands of the opposing party or parties when such settlement is unfavorable to it in the judgment of the party having

the difficulty. No force majeure event which renders either of the parties unable to perform under this Contract shall relieve Bartlett of its obligation to make payments to the Commission as required under Section 7 of this Contract and such payments shall continue as if the Bartlett Unit System were receiving its Full Water Requirements from the Commission.

SECTION 13. COMMISSION DEFAULTS.

Failure by the Commission to deliver Lake Water to Bartlett as required by this Contract or failure of the Commission to perform any other obligation under this Contract, and the continuation of that failure to perform for 30 days after written notice from Bartlett to the Commission of such failure, shall be a default of the Commission under this Contract, unless any such failure is excused pursuant to Section 12 of this Contract. If the Commission defaults under this Contract, then Bartlett may bring any action against the Commission allowed by law. No Commission default shall relieve Bartlett of its obligation to make payments to the Commission as required under Section 7 of this Contract and such payments shall continue as if the Bartlett Unit System were receiving its Full Water Requirements from the Commission.

SECTION 14. BARTLETT OBLIGATION UNCONDITIONAL.

Bartlett shall have no right to terminate, cancel, or rescind this Contract; no right to withhold from the Commission or any Trustee who is an assignee of the Commission pursuant to Section 11 of this Contract payments due or to become due under this Contract; no right to recover from the Commission or any such Trustee amounts previously paid under this Contract unless paid in error or contrary to the provisions of this Contract or law; no right of reduction or set-off against the amounts due or to become due under this Contract to the Commission or any such Trustee; and no lien on any amounts in any fund established by the Commission or such

Trustee for any reason or on account of the existence or occurrence of any event, condition, or contingency, whether foreseen or unforeseen or foreseeable or unforeseeable by Bartlett or the Commission or any other person, including by way of illustration and not limitation by reason of the fact that the Waterworks System in whole or in part is not completed, operable, or operating; or the output of the Waterworks System in whole or in part is suspended, interrupted, interfered with, reduced, or curtailed; or any party to the Chicago Contract, including the City of Chicago, does not perform in whole or in part thereunder; or the Water Allocation of any of the Commission's Contract Customers is modified or terminated or any such Contract Customer does not perform in whole or in part any agreement or instrument, it being the intent hereof that Bartlett shall be absolutely and unconditionally obligated to make all payments under this Contract. The Commission may issue its Bonds in specific reliance on the limitations set forth in this Section 14 with respect to the rights of Bartlett.

SECTION 15. COOPERATION IN CONSTRUCTION: EASEMENTS.

Bartlett shall cooperate with the Commission in the construction and acquisition of the Waterworks System. Bartlett is responsible for acquiring all necessary real property and easements within the Village to build the Connection Facilities and shall transfer that insured real property and insured easements to the Commission upon acquisition. Additionally, Bartlett, within 30 days after Commission's request therefor, shall grant without charge to the Commission all required construction easements and all insured easements necessary for portions of the Waterworks System to be located on Bartlett's property, free and clear of all liens, claims, encumbrances, and restrictions unless otherwise approved by the Commission in writing, provided the Commission agrees to restore the easement property in a reasonable

manner after construction. Bartlett shall grant the Commission all access to its property necessary to construct and install the Commission Connection Facilities and all other equipment and appurtenant devices to the Point of Delivery.

SECTION 16. COOPERATION IN ISSUANCE OF BONDS.

Bartlett shall cooperate with the Commission in the issuance of Bonds. In connection therewith, Bartlett shall comply with all reasonable requests of the Commission and shall upon request do as follows:

- A. Make available general and financial information about itself; and
- B. Consent to publication and distribution of its financial information; and
- C. Certify that general and financial information about it is accurate, does not contain an untrue statement of a material fact, and does not omit to state a material fact necessary in order to make the statements in that information, in light of the circumstances under which they were made, not misleading; and
- D. Make available certified copies of official proceedings; and
- E. Provide reasonable certifications to be used in a transcript of closing documents; and
- F. Provide and pay for reasonably requested opinions of counsel of its choice as to the validity of its actions taken with respect to, and the binding effect of, this Contract, title to the Bartlett Unit System, pending or threatened litigation which could materially affect its performance hereunder, and other reasonably related opinions.

SECTION 17. REGULATORY BODIES.

The Commission and Bartlett through this Contract seeks to exercise and maintain all sovereign rights granted to it under and through the Constitution and laws of the State of

Illinois. This Contract shall be subject to all valid rules, regulations, and laws applicable hereto passed or promulgated by the United States of America, the State of Illinois, any governmental body or agency having lawful jurisdiction, and any authorized representative or agent of any of them; provided, however, that this clause shall not be construed as waiving the right of either party to challenge the validity of such rule, regulation, or law on any basis, including the impairment of this Contract.

SECTION 18. OTHER WATER SUPPLIERS.

Notwithstanding any of the provisions of this Contract, the Commission is not prohibited by this Contract from entering into cooperative arrangements with other suppliers or users of Lake Water to provide Lake Water to each other to meet each other's water needs, provided that these arrangements do not interfere, except in emergencies, with the delivery of Lake Water to the Bartlett Unit System.

SECTION 19. NOTICES; EVIDENCE OF ACTIONS; WAIVER.

A. Notices. All notices or communications provided for herein shall be in writing and shall be delivered either in person or by United States mail, by certified mail with return receipt requested, postage prepaid, and addressed as follows:

To the Commission:
DuPage Water Commission
600 East Butterfield Road
Elmhurst, Illinois 60126
Attention: General Manager

To Bartlett:
Village of Bartlett
228 S. Main Street
Bartlett, Illinois 60103
Attention: Village Administrator

until and unless other addresses or addressees are specified by notice given in accordance herewith.

B. Evidence of Actions. Any action hereunder to be taken by the Commission or Bartlett may be evidenced by copy of official proceedings (including pertinent minutes, motions, resolutions, or ordinances, as applicable) duly certified by the Clerk of the Commission or the Village Clerk of Bartlett.

All notices, demands, requests, consents, approvals, and other instruments required or permitted to be made or given by Bartlett pursuant to this Contract shall be in writing, signed by a duly authorized officer, agent, or attorney of Bartlett.

C. Waiver. No course of dealing or failure of the Commission or Bartlett to enforce strictly any term, right, or condition of this Contract shall be construed as a waiver of such term, right, or condition. No express waiver of any term, right, or condition of this Contract shall operate as a waiver of any other term, right, or condition.

SECTION 20. EFFECTIVE DATE; TERMINATION; PAYMENT OF INTERIM COSTS; TERM.

A. Effective Date. Except for the provisions of Section 10 of this Contract relating to the commencement of certain work following execution of this Contract and except for the provisions of Section 21 of this Contract relating to the payment of certain costs, as to which provisions this Contract shall be effective immediately after authorization and execution by both parties hereto, this Contract shall be effective upon authorization and execution by both parties hereto and issuance by the State of Illinois Department of Natural Resources, Office of Water Resources, of a Water Allocation permit to Bartlett for each discrete and non-contiguous service

area served by the Bartlett Unit System.

B. IDNR Approval. If the State of Illinois Department of Natural Resources, Office of Water Resources, in a final, non-appealable order declines Bartlett's application for a Water Allocation permit for Bartlett's service area served by the Bartlett Unit System, this Contract shall be of no force or effect except to the extent provided in Sections 10 and 21 of this Contract as aforesaid. If the State of Illinois Department of Natural Resources, Office of Water Resources, has not approved Bartlett's application for a Water Allocation permit for Bartlett's service area served by the Bartlett Unit System, either party, by written notice to the other, may terminate this Contract, in which event this Contract shall be of no force or effect except to the extent provided in Sections 10 and 21 of this Contract as aforesaid.

C. Commission Right to Terminate. If the Bartlett Unit System has not been constructed, installed, and completed to a point where it is capable of serving its intended function at the time Bartlett first becomes obligated to make payments of Operation and Maintenance Costs pursuant to Subsection 7M of this Contract, the Commission may, in its sole and absolute discretion, terminate this Contract, in which event the Commission shall give notice to Bartlett not less than 20 days in advance of its intention to terminate this Contract and shall provide Bartlett an opportunity for a hearing before the Commission prior to the effective date of such termination and, upon the concurrence of a majority of the Commissioners of the Commission following the conclusion of such hearing, this Contract shall be of no further force or effect except for the provisions of Subsection 20D below, as to which provisions this Contract shall remain in full force and effect.

D. Payment of Interim Costs. Whether or not the Bartlett Unit System is ever

completed, operable, or operating, Bartlett shall pay to the Commission all attorneys', engineering, and administrative fees, costs, and expenses incurred by the Commission for any work related to, or participation in, any regulatory proceeding which shall be required or requested of the Commission by the Illinois Department of Department of Natural Resources, Office of Water Resources, or by Bartlett as a result of, or a occasioned by, this Contract and, further, shall pay to the Commission all attorneys', engineering, and administrative fees, costs, and expenses incurred by the Commission in connection with the negotiation, preparation, consideration, and review of this Contract and in implementing the terms of this Contract, including without limitation the costs of the design and construction of the Commission Connection Facilities. If the Bartlett Unit System has not been completed as and when required by Subsection 20C above and the Commission elects, in its sole and absolute discretion, to terminate this Contract pursuant to Subsection 20C above, then Bartlett's payment hereunder shall be due and payable immediately after receipt by it of an invoice from the Commission detailing such costs, after deducting therefrom the amount or amounts of any prepayments made pursuant to Subsection 7K of this Contract. If the amount or amounts of any such prepayments exceed Bartlett's payment obligation hereunder, the Commission shall refund the difference to Bartlett. If either (i) the Bartlett Unit System is completed as and when required by Subsection 20C above or (ii) if not completed, the Commission does not elect to terminate this Contract, then such costs shall be treated as part of the Connection Facilities Cost provided in Subsection 7C of this Contract.

E. Term. Unless this Contract is sooner terminated by the Commission pursuant to Subsection 20C above, this Contract shall continue in force and effect until February 24, 2024.

SECTION 21. GOVERNING LAW AND VENUE.

This Contract shall be construed exclusively under the applicable laws, but not the conflicts of laws rules, of the State of Illinois. Venue for any litigation arising out of this Contract shall only be proper in the Eighteenth Judicial Circuit Court, DuPage County, Illinois.

SECTION 22. MODIFICATIONS OR AMENDMENTS.

This Contract shall not be modified or amended in any way except in writing approved by both parties hereto. No such modification or amendment shall materially impair or adversely affect the ability or obligation of Bartlett to make payments to the Commission to meet the Commission's obligations under the Chicago Contract, the Charter Customer Contract, and the Bond Ordinances.

SECTION 23. EXHIBITS INCORPORATED.

Exhibits A, B-1, B-2, C, D, E, F, G and H to this Contract are hereby fully incorporated into this Contract as substantive provisions of this Contract.

SECTION 24. EXECUTION IN COUNTERPARTS.

This Contract shall be executed in two counterparts, each of which shall be deemed to be an original, and each of which shall constitute but one and the same instrument.

[SIGNATURE PAGE FOLLOWS]

IN WITNESS WHEREOF, the parties hereto have caused their respective corporate names to be subscribed hereto and their respective corporate seals to be affixed hereto and attested by their duly authorized officers, all on the date set opposite their respective corporate names.

Date: _____, 2017

VILLAGE OF BARTLETT

By: _____
Its _____

ATTEST:

Village Clerk

Date: _____, 2017

DUPAGE WATER COMMISSION

By: _____
Its _____

ATTEST:

Clerk

EXHIBITS

- Exhibit A: Bartlett System and Service Area
- Exhibit B-1: Preliminary Plans for Bartlett System Connection Facilities
- Exhibit B-2: Preliminary Plans for Commission Connection Facilities and the Points of Delivery
- Exhibit C: Calculation of Water Storage Requirements
- Exhibit D: Metering Station Easement Agreement
- Exhibit E: Illustrative Calculation of Capital Cost Recovery Charge
- Exhibit F: Illustrative Schedule of Events
- Exhibit G: Intergovernmental Agreement Concerning Loan for Capital Cost Recovery Charge to the Village of Bartlett
- Exhibit H: Intergovernmental Agreement Concerning Loan for Connection Facilities to Implement Water Service to the Village of Bartlett

EXHIBIT A

BARTLETT SYSTEM AND SERVICE AREA

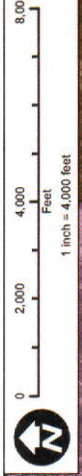
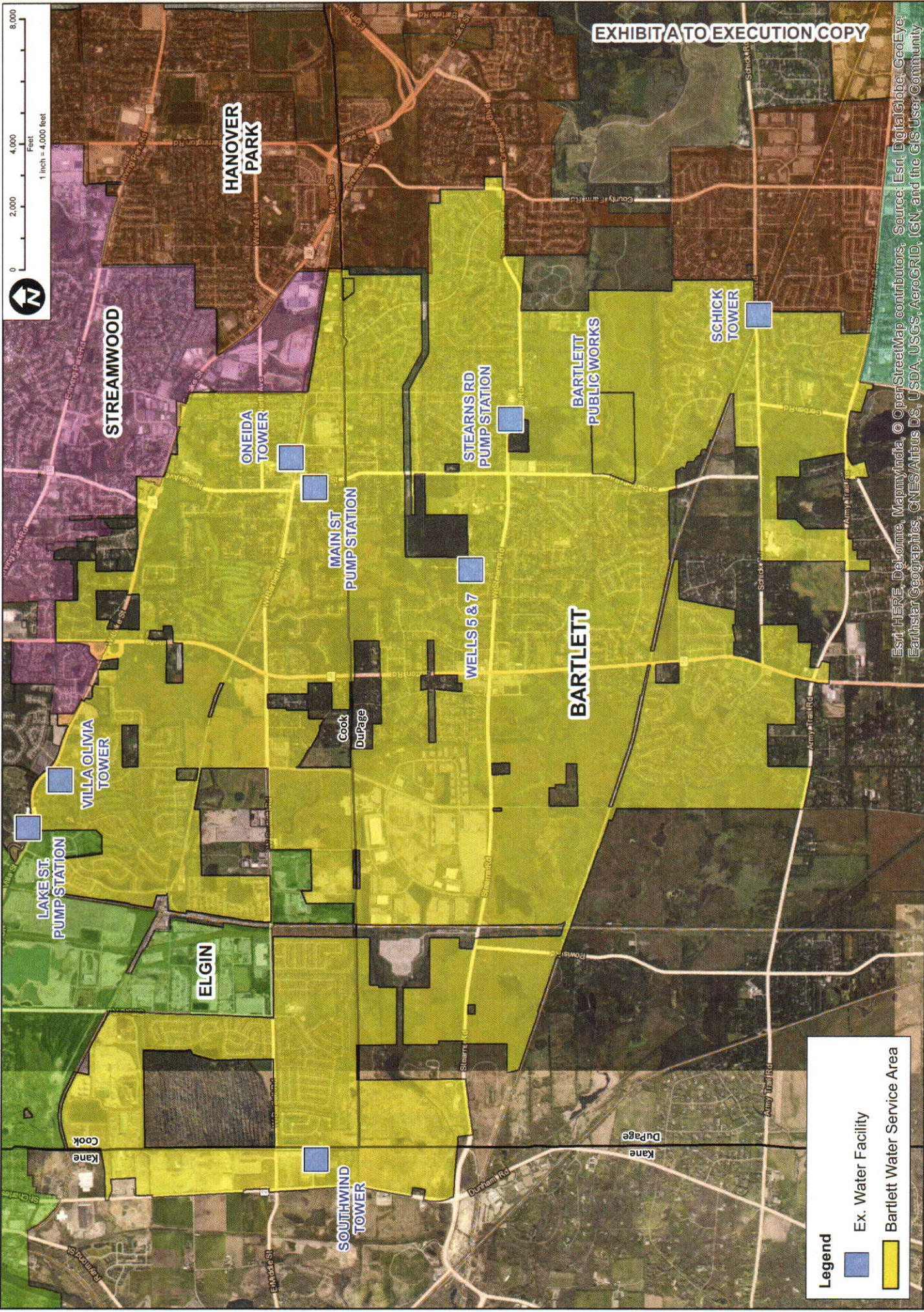

Legend

- Ex. Water Facility
- Bartlett Water Service Area

CHRISTOPHER B. BURKE ENGINEERING LTD
 9575 West Higgins Road, Suite 600
 Rosemont, Illinois 60018
 (847) 823-0500

VILLAGE OF BARTLETT
 228 S. Main Street
 Bartlett, IL 60103

NO.	DATE	NATURE OF REVISION	BY	CHKD.	DATE

PROJECT NO. 11-1824
 DATE: 01-23-17
 DRAWING NO. EXH A

EXHIBIT A
BARTLETT WATER SERVICE AREA

CLIENT: CHRISTOPHER B. BURKE ENGINEERING LTD
 EST. HERE, DeLorme, MapmyIndia, © OpenStreetMap contributors, Source: Esri, DigitalGlobe, GeoEye, Earthstar Geographics, CNES/Airbus DS, USDA, USGS, AeroGRID, IGN, and the GIS User Community
 TITLE:

EXHIBIT B-1

**PRELIMINARY PLANS FOR BARTLETT SYSTEM
CONNECTION FACILITIES**

EXHIBIT B-1

PRELIMINARY PLANS FOR BARTLETT
SYSTEM CONNECTION FACILITIES

MINIMUM REQUIREMENTS FOR PRESSURE ADJUSTING (PA)
STATIONS AND SCHEMATICS

1. Rate Controllers shall be adjusted and the water distribution shall otherwise be operated to take a normally uniform flow rate from the DWC system. The maximum hourly rate should in no case be greater than 1.7 times the average annual hourly rate based on the current Lake Michigan water allocation for the PA station. The adequacy of customer system storage and proper operation of storage facilities to assure uniform take-off is the customer's responsibility.
2. Designs shall provide for the appropriate fluctuation of customer storage facility levels to assure uniform take-off. Elevated storage tanks shall be fluctuated appropriately during sub freezing conditions.
3. Emergency bypass lines, flow rate controllers and system isolation check valves shall be required in all designs.
4. Altitude valves or other appropriate means for preventing elevated and ground storage tank overflows are recommended if such provisions do not already exist in the customer's system.
5. Surge relief facilities for protection of both the customer and DWC facilities shall be required.
6. The type and design of the PA station will be dependent upon:
 - a. The difference between, (i) the minimum DWC system pressure (hydraulic grade) 10 feet downstream of the OWC Metering Station (MS) and, (ii) the customer's elevated tank overflow or system pressure.
 - b. Whether ground storage will be used to receive water at the PA station.

In general, the recommended design types for the various receiving facility designs and the differential between the minimum DWC system grade (at the point of delivery) and the customer system elevated tank overflows or system pressure are as follows:

<u>Design Type</u>	<u>Head (DWC - Customer)</u>
Pressure Reducing (Type A & 8)	> / = 28 feet
Rate Control (Type C)	< 28 feet & >/= 0 feet
Pressure Increasing (Type D)	< 0 feet

EXHIBIT B-1

PRELIMINARY PLANS FOR BARTLETT
SYSTEM CONNECTION FACILITIES

7. Where pumping stations are required (Type D), each station shall be equipped with three (3) pumping units of equal size. Each unit shall have rated capacity of approximately equal to the average day, year 2020 flow, at the station. Two (2) pumping units shall have a combined capacity to provide maximum day, year 2020 flow (1.7 times average day year 2020 flow). The third unit is for standby. A fourth space is shown on the pumping station (Type D) schematic for an additional pumping unit at the customer's option.
8. The facility requirements indicated are for illustrative purposes showing general guidelines and various design functions to be provided. Each station shall be designed and proper equipment shall be selected to meet local and specific conditions.
9. Emergency conditions may permit three (3) times average day flow at the PA based on the year 2020 Lake Michigan Water Allocation or 1500 GPM, whichever is greater.
10. The Commission will only provide a chlorine residual meeting State and Federal Standards at the point of delivery. Additional chlorination facilities, if required, shall be provided by the customer at the customer's expense.

SCHEMATIC OF PRESSURE REDUCING STATION UTILIZING GROUND STORAGE TYPE A

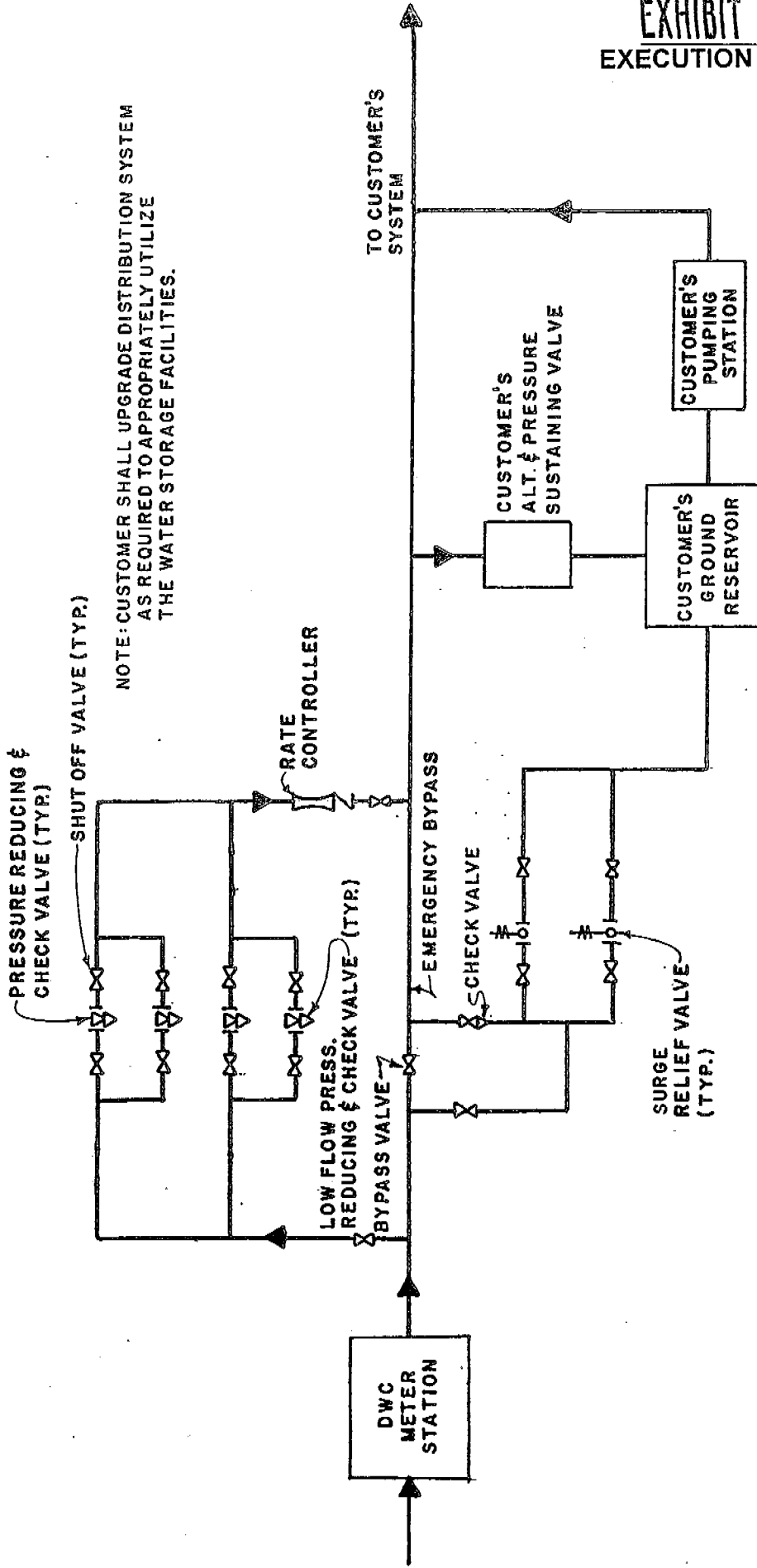

NOTE: CUSTOMER SHALL UPGRADE DISTRIBUTION SYSTEM AS REQUIRED TO APPROPRIATELY UTILIZE THE WATER STORAGE FACILITIES.

SCHEMATIC OF PRESSURE REDUCING STATION TYPE B

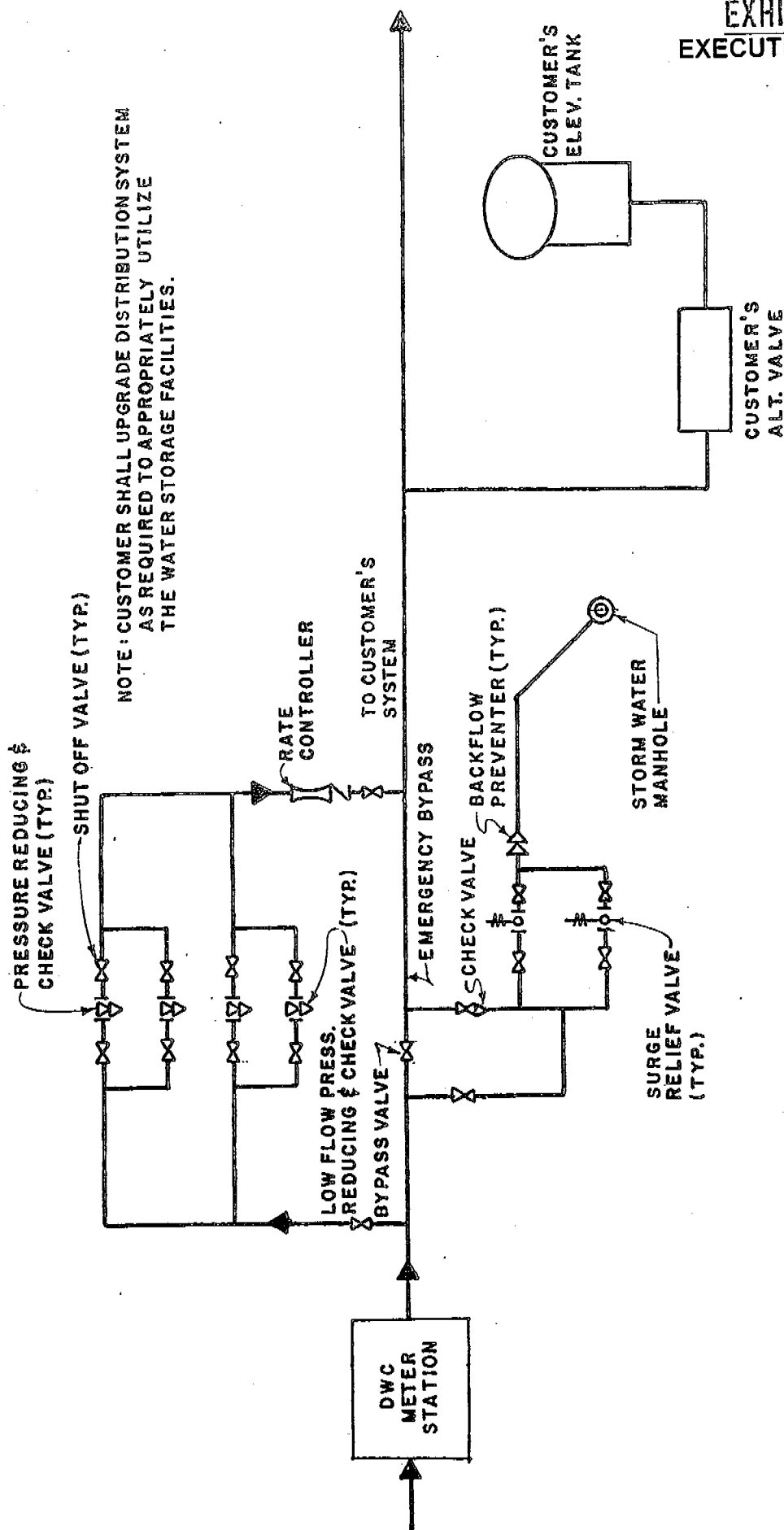

NOTE: CUSTOMER SHALL UPGRADE DISTRIBUTION SYSTEM AS REQUIRED TO APPROPRIATELY UTILIZE THE WATER STORAGE FACILITIES.

SCHEMATIC OF RATE CONTROL STATION TYPE C

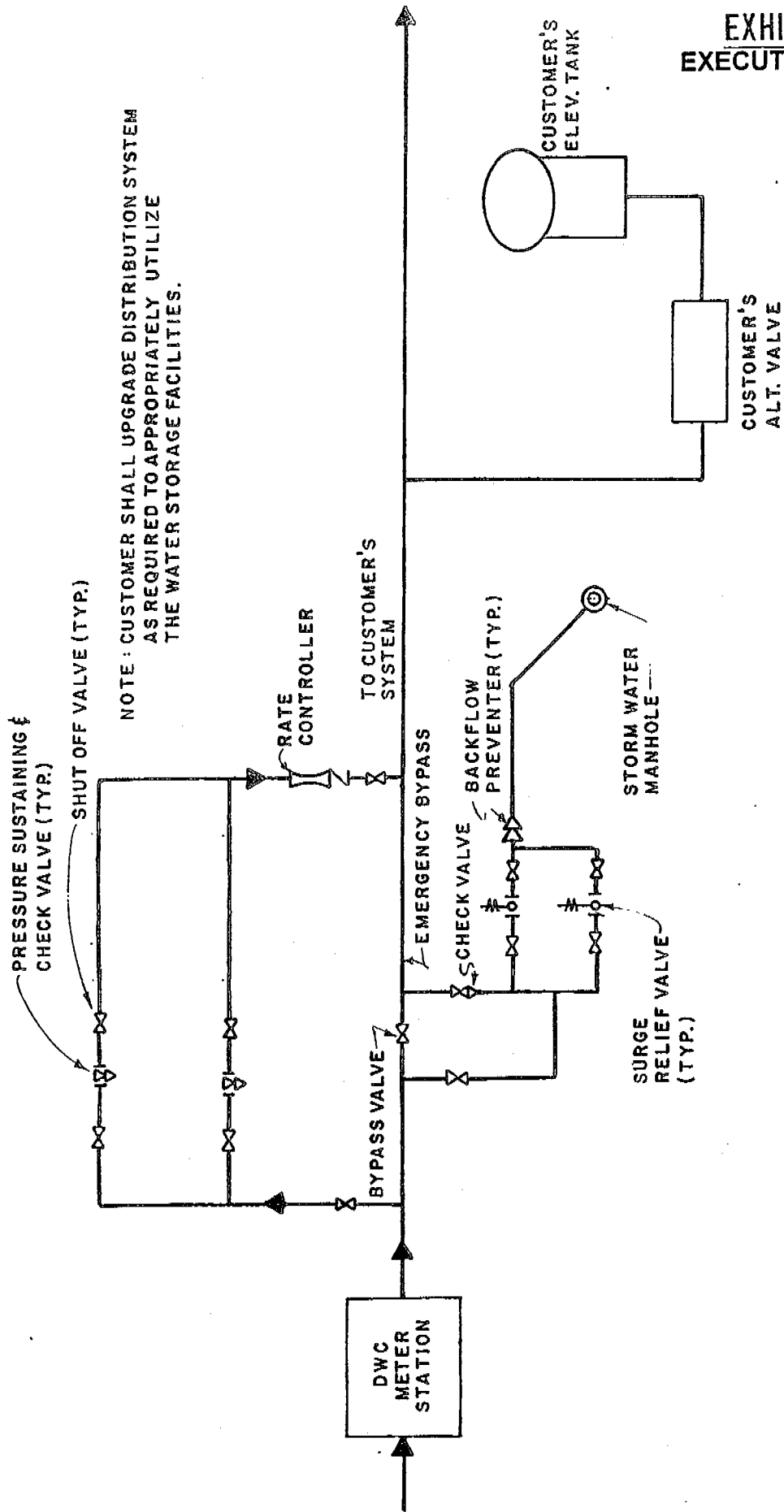

SCHEMATIC OF PRESSURE INCREASING STATION TYPE D

EXHIBIT B-1 to
EXECUTION COPY

NOTE: CUSTOMER SHALL UPGRADE DISTRIBUTION SYSTEM
AS REQUIRED TO APPROPRIATELY UTILIZE THE
WATER STORAGE FACILITIES.

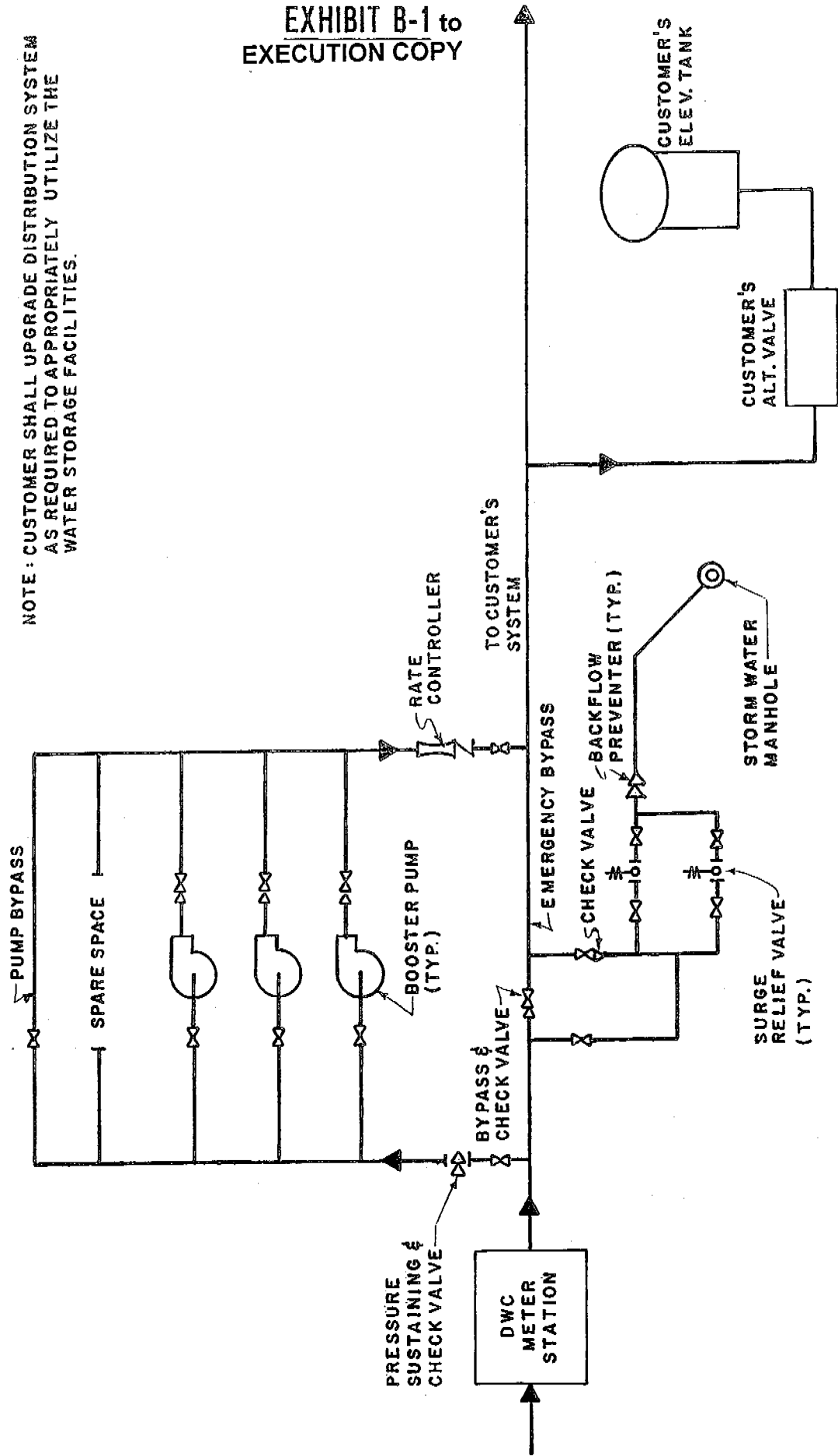
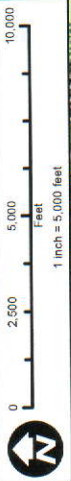
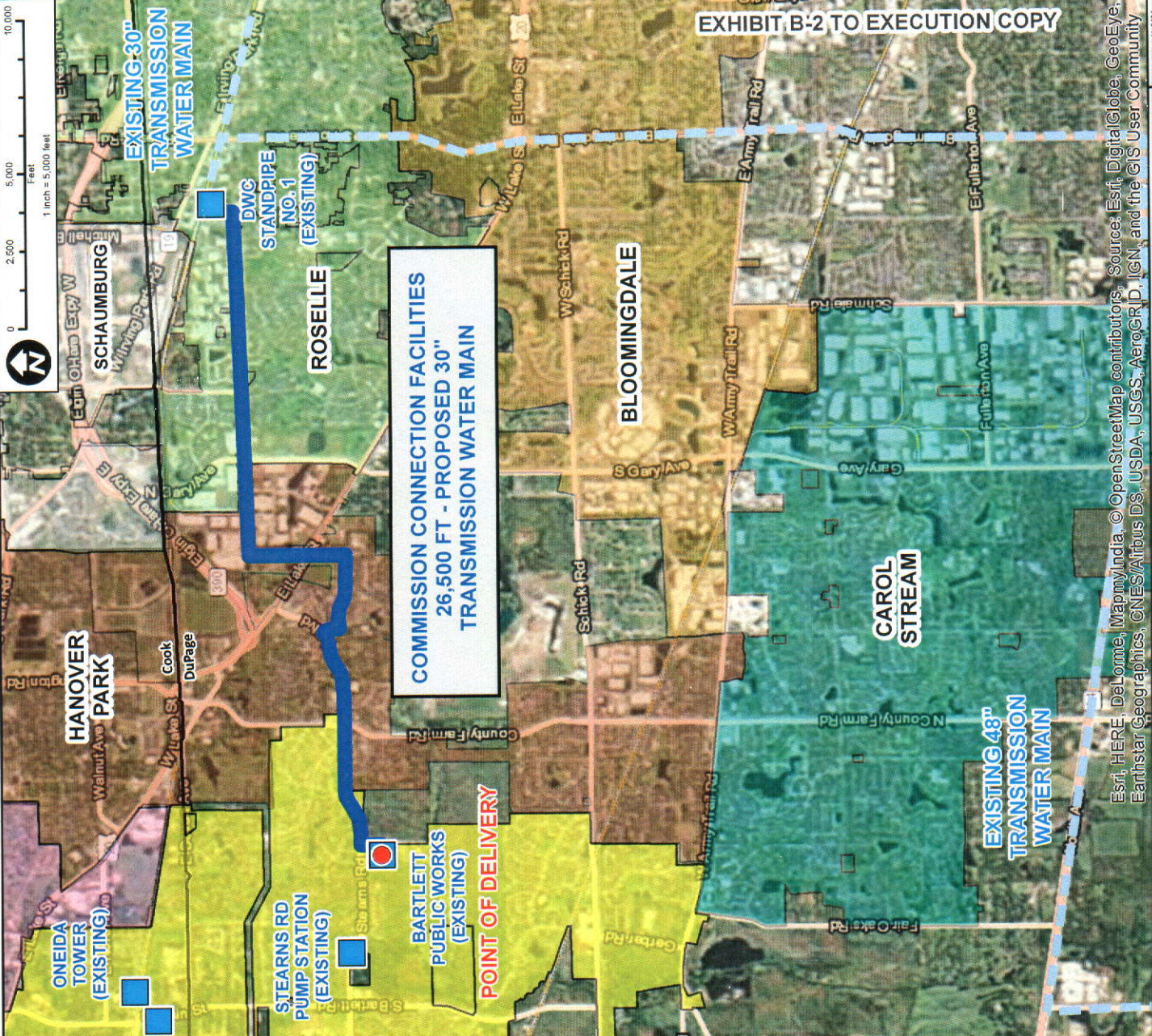

EXHIBIT B-2

PRELIMINARY PLANS FOR COMMISSION CONNECTION
FACILITIES AND THE POINTS OF DELIVERY



**COMMISSION CONNECTION FACILITIES
26,500 FT - PROPOSED 30"
TRANSMISSION WATER MAIN**

POINT OF DELIVERY

Item	Description	Unit	Estimated Quantity	Unit Price	Total Amount
1	Connection to Existing DWC System	LS	1	\$ 75,000	\$ 75,000
2	30" Welded Steel Transmission Main (in pavement)	LF	26,500	\$ 390	\$ 10,335,000
3	J&B Crossing - County Farm Rd	LF	200	\$ 1,200	\$ 240,000
4	J&B Crossing - Lake Street	LF	250	\$ 1,200	\$ 300,000
5	J&B Crossing - West Branch DuPage River	LF	45	\$ 1,200	\$ 54,000
6	J&B Crossing - RR Spur	LF	50	\$ 1,200	\$ 60,000
7	Sanitary & Storm Sewer Crossings R&R	EA	76	\$ 5,000	\$ 380,000
8	Pavement Remove and Replace	LF	26,500	\$ 80	\$ 2,120,000
9	Curbs & Gutter R&R (alley near DWC Standpipe)	LF	782	\$ 50	\$ 39,100
10	Blow Off Hydrant Assembly	EA	7	\$ 45,000	\$ 315,000
11	Material Testing	LS	1	\$ 80,000	\$ 80,000
12	30" Butterfly Valve in Vault	EA	4	\$ 65,000	\$ 260,000
13	Traffic Control	LS	1	\$ 250,000	\$ 250,000
14	Erosion Control (allowance)	LS	1	\$ 50,000	\$ 50,000
15	Permits and Utility Fees (allowance)	LS	17	\$ 30,000	\$ 510,000
16	Cathodic Protection (allowance)	LS	1	\$ 250,000	\$ 250,000
17	Mobilization	LS	1	\$ 75,000	\$ 75,000
18	Construction Layout	LS	1	\$ 500,000	\$ 500,000
19	Metering Station	LS	1	\$ 500,000	\$ 500,000
Subtotal					\$ 16,093,100
Engineering & Legal @ 15%					\$ 2,410,000
Contingency @ 15%					\$ 2,410,000
Estimated Construction Costs					\$ 20,913,100

Legend

- Proposed Point of Delivery
- Existing Water Facility
- Prop. DWC Transmission Main Connection Facilities
- - - Existing DWC Transmission Main
- Bartlett Boundary

CHRISTOPHER B. BURKE
ENGINEERING LTD.
9575 West Higgins Road, Suite 600
Rosemont, Illinois 60018
(847) 823-0500

VILLAGE OF BARTLETT
228 S. Main Street
Bartlett, IL 60103

**EXHIBIT B-2
POINT OF DELIVERY**

DATE: 01-11-2017
DRAWING NO: EXH B-2

PRJ. NO.: 11-0444

TITLE:

DESIGN	DATE
CHECK	DATE
REVISION	DATE
DATE	DATE

MAILED BY: []
DATE: []
SCALE: []
PROJECT: []

PROJECT: []
DATE: []

Esri, HERE, DeLorme, MapmyIndia, © OpenStreetMap contributors, Source: Esri, DigitalGlobe, GeoEye, Earthstar Geographics, CNES/Airbus DS, USDA, USGS, AeroGRID, IGN, and the GIS User Community

EXHIBIT C

CALCULATION OF WATER STORAGE REQUIREMENTS

CUSTOMER WATER STORAGE

CUSTOMER	EXISTING STORAGE (MG)	2016 ALLOCATION (IN MGD)	% OF SYSTEM	REQUIRED STORAGE	SHALLOW WELL ALLOWANCE	% OF DWC STORAGE (MG)	STORAGE ABOVE OR (BELOW) REQ
ADDISON	6.75	4.366	4.23%	8.73	0.87	2.64	1.53
ARGONNE NAT'L LAB	1.60	0.758	0.73%	1.52	0.15	0.46	0.69
BARTLETT (1)	5.00	3.190	3.09%	6.38	0.64	1.93	1.19
BENSENVILLE	3.55	2.598	2.52%	5.20	0.00	1.57	(0.07)
BLOOMINGDALE	4.80	2.935	2.84%	5.87	0.59	1.78	1.29
CAROL STREAM	6.50	4.519	4.38%	9.04	0.90	2.74	1.10
CLARENDON HILLS	1.25	0.866	0.84%	1.73	0.17	0.52	0.22
DARIEN	4.00	3.121	3.02%	6.24	0.62	1.89	0.27
DOWNERS GROVE	8.00	6.995	6.78%	13.99	1.40	4.24	(0.36)
DUPAGE COUNTY (Glen Ellyn Heights)	0.25	0.251	0.24%	0.50	0.05	0.15	(0.05)
DUPAGE COUNTY (SERWF)	0.88	0.682	0.66%	1.36	0.14	0.41	0.07
DUPAGE COUNTY (Steel Run)	0.25	0.187	0.18%	0.37	0.04	0.11	0.03
DUPAGE COUNTY (Hobsen Rd.)	0.25	0.099	0.10%	0.20	0.02	0.06	0.13
ELMHURST	15.00	4.729	4.58%	9.46	0.95	2.86	9.35
GLENDALE HEIGHTS	4.70	2.934	2.84%	5.87	0.59	1.78	1.20
GLEN ELLYN (5)	3.20	3.093	3.00%	6.19	0.62	1.87	(0.49)
HINSDALE	4.50	2.858	2.77%	5.72	0.57	1.73	1.09
IAWC-ARROWHEAD	0.40	0.190	0.18%	0.38	0.04	0.12	0.17
IAWC-COUNTRY CLUB	0.20	0.105	0.10%	0.21	0.02	0.06	0.07
IAWC-DUPAGE/LISLE (2)	0.91	0.573	0.56%	1.15	0.11	0.35	0.23
IAWC-LOMBARD HEIGHTS (3)	0.07	0.065	0.06%	0.13	0.01	0.04	(0.01)
IAWC-LIBERTY RIDGE EAST (5)	0.07	0.046	0.04%	0.09	0.01	0.03	0.02
IAWC-LIBERTY RIDGE WEST (4)	0.40	0.331	0.32%	0.66	0.07	0.20	0.00
IAWC-VALLEY VIEW	0.88	0.700	0.68%	1.40	0.14	0.42	0.04
ITASCA	3.50	1.824	1.77%	3.65	0.36	1.10	1.32
LISLE (2)	4.79	3.167	3.07%	6.33	0.63	1.92	1.01
LOMBARD (3)	6.15	5.017	4.86%	10.03	1.00	3.04	0.15
NAPERVILLE	43.90	20.531	19.89%	41.06	4.11	12.43	19.38
OAK BROOK	8.00	4.385	4.25%	8.77	0.88	2.66	2.76
OAKBROOK TERRACE	0.50	0.293	0.28%	0.59	0.00	0.18	0.09
ROSELLE	1.75	2.296	2.22%	4.59	0.00	1.39	(1.45)
VILLA PARK	3.80	2.182	2.11%	4.36	0.44	1.32	1.19
WESTMONT	4.50	3.019	2.92%	6.04	0.60	1.83	0.89
WHEATON	7.26	5.933	5.75%	11.87	1.19	3.59	0.17
WILLOWBROOK	4.00	1.378	1.33%	2.76	0.00	0.83	2.08
WINFIELD (4)	1.60	1.118	1.08%	2.24	0.22	0.68	0.26
WOOD DALE	3.35	1.654	1.60%	3.31	0.33	1.00	1.37
WOODRIDGE	6.15	4.237	4.10%	8.47	0.85	2.57	1.09
CUSTOMER TOTAL	172.66	103.225	100.00%	206.45	19.33	62.50	48.04
COMMISSION TOTAL	62.50						
TOTAL	235.16						

- (1) 3 MG OF ADDITIONAL GROUND STORAGE IS PLANNED TO BE ADDED BY 2019
- (2) LISLE CONTRACTED STORAGE TO IAWC DUPAGE/LISLE
- (3) LOMBARD CONTRACTED STORAGE TO IAWC LOMBARD
- (4) WINFIELD CONTRACTED STORAGE TO IAWC LIBERTY RIDGE WEST
- (5) GLEN ELLYN CONTRACTED STORAGE TO IAWC LIBERTY RIDGE EAST

EXHIBIT D TO
EXECUTION COPY

EXHIBIT D

METERING STATION EASEMENT AGREEMENT

**EXHIBIT D to
Draft Copy 12/16**

**DUPAGE WATER COMMISSION
METERING STATION
EASEMENT AGREEMENT
(Village of Bartlett Unit System)**

PERMANENT REAL ESTATE TAX INDEX NO. _____

Prepared by and Mail to:

**John Spatz
General Manager
DuPage Water Commission
600 East Butterfield Road
Elmhurst, Illinois 60126-4642
Phone: 630-834-0100
Fax: 630-834-0120**

**METERING STATION
EASEMENT AGREEMENT
(Village of Bartlett Unit System)**

THIS EASEMENT AGREEMENT, made and entered into this ____ day of _____, 2017, by and between the DUPAGE WATER COMMISSION, a county water commission created and existing under the laws of the State of Illinois (the "Commission") and the VILLAGE OF BARTLETT, a unit of local government created and existing under the laws of the State of Illinois (the "Customer"),

WITNESSETH:

WHEREAS, the Commission and the Customer have entered into a certain Water Purchase and Sale Contract dated as of _____, 2017 (the "Contract"); and

WHEREAS, the Contract provides that the Commission is to furnish, install, own, operate, maintain, repair, and replace certain equipment and devices, together with certain above-ground structures and portions of its water distribution mains, including underground feeder pipe lines and related equipment, for properly conveying and measuring the quantity of Lake Michigan water delivered by the Commission to the Customer under the Contract (each collectively referred to as a "Village of Bartlett Metering Station"); and

WHEREAS, the Contract provides that each Village of Bartlett Metering Station is to be located at a site selected and provided by the Customer, subject to review and approval by the Commission; and

WHEREAS, the Customer has selected the site legally described and generally depicted in Exhibit A attached hereto and by this reference incorporated herein and made a part hereof (the "Village of Bartlett Building Easement") for the location of a

Village of Bartlett Metering Station as generally depicted in Exhibit B attached hereto and by this reference incorporated herein and made a part hereof; and

WHEREAS, the Commission has reviewed the Village of Bartlett Building Easement and approved the same for the location of the Village of Bartlett Metering Station; and

WHEREAS, the Commission has submitted to the Customer for review the drawings and specifications for the Village of Bartlett Metering Station; and

WHEREAS, the Commission and the Customer desire to enter into this Easement Agreement in order to provide the Commission with a sufficient property interest in the Village of Bartlett Building Easement to fulfill the provisions and purpose of the Contract;

NOW, THEREFORE, in consideration of the foregoing and for other good and valuable consideration, the receipt and sufficiency of which is hereby acknowledged, and in the exercise of their powers and authority under the intergovernmental cooperation provisions of Article VII, Section 10 of the Illinois Constitution of 1970, and other applicable authority, the Commission and the Customer hereby agree as follows:

1. The foregoing recitals are hereby incorporated herein as substantive provisions of this Easement Agreement.

2. The Customer hereby grants, conveys, warrants, and dedicates to the Commission, its successors and assigns, a perpetual non-exclusive easement to construct, furnish, install, own, operate, maintain, test, inspect, remove, repair, and replace the Village of Bartlett Metering Station at, in, under, and upon the Village of

Bartlett Building Easement, together with all reasonable rights of ingress and egress along or across any adjoining lands of, or under the jurisdiction and control of, the Customer. The Customer hereby further grants, conveys, warrants, and dedicates to the Commission, its successors and assigns, a non-exclusive perpetual access easement along and across the lands described as the access easement on Exhibit A.

3. The Village of Bartlett Metering Station shall not be located, constructed, or maintained in any manner not in substantial conformity with Exhibit B without the express consent of the Customer, which consent shall not be unreasonably withheld.

4. The Commission shall exercise the easement rights hereby granted with due care, and shall not unreasonably interfere with, damage, or harm any Customer property located upon the Village of Bartlett Building Easement and Customer's adjacent property.

5. All fences, roads, landscaping, and improvements shall be restored to former condition by the Commission if disturbed or altered in any manner by construction or maintenance activities of the Commission.

6. The Customer hereby reserves the right to use the Village of Bartlett Building Easement and its adjacent property in any manner that will not prevent or interfere in any way with the exercise by the Commission of the rights granted hereunder; provided, however, that the Customer shall not in any manner disturb, damage, destroy, injure, obstruct, or permit to be obstructed the Village of Bartlett Metering Station without the express prior written consent of the Commission; nor shall the Customer permanently or temporarily improve, damage, or obstruct the Village of

Bartlett Building Easement or the access easement premises in any manner that would impair the exercise by the Commission of the rights hereby granted.

7. The Customer agrees to indemnify and defend the Commission with respect to any and all claims of damages to persons or property that may arise directly from the negligence of the Customer, or its agents or employees, in performing any work on the Village of Bartlett Building Easement and Customer's adjacent property in conjunction with its rights pursuant to Paragraph 6 hereof, and, except as otherwise provided in the Contract, the Commission agrees to indemnify and defend the Customer with respect to any and all claims of damages to persons or property that may arise directly from the negligence of the Commission, or its agents or employees, in performing any work on the Village of Bartlett Building Easement and Customer's adjacent property in conjunction with its rights pursuant to Paragraphs 2, 4, and 5 hereof. The Customer shall provide to the Commission, and the Commission shall provide to the Customer, a certificate of insurance or proof of self-insurance coverage as evidence of its continuing ability to meet the obligation established in this Paragraph, and both shall maintain such coverage at all times.

8. This Easement Agreement shall constitute and stand in the place of all Customer permits required by the Commission or its contractor to construct, furnish, install, own, operate, maintain, test, inspect, remove, repair, and replace the Village of Bartlett Metering Station at, in, under, and upon the Village of Bartlett Building Easement, and the Customer hereby agrees to execute any and all additional documents, approvals, waivers, or consents, if any, that may be reasonably necessary

for the Commission to secure any permits required from any county, state, or federal agency for or in connection with constructing, furnishing, installing, owning, operating, maintaining, testing, inspecting, repairing, removing, or replacing the Village of Bartlett Metering Station.

9. In the event that the Contract is terminated without renewal with respect to the Customer, the Commission shall, within 90 days, execute and deliver to the Customer an appropriate document evidencing the termination of this Easement Agreement and releasing the permanent easement and access rights hereby granted. The Commission may, within said 90 day period, at its own expense, and in its own discretion, remove the Village of Bartlett Metering Station from the Village of Bartlett Building Easement. If the Commission fails to remove the Village of Bartlett Metering Station, as aforesaid, the Customer may take title to the Village of Bartlett Metering Station.

10. All rights, title, and privileges herein granted, including all benefits and burdens, shall run with the land and shall be binding upon and inure to the benefit of the parties hereto and their respective grantees, successors, assigns, and legal representatives.

11. All representations and warranties contained herein shall survive the execution of this Easement Agreement and the recordation hereof and shall not be merged.

IN WITNESS WHEREOF, the parties hereto have caused this instrument to be executed by their proper representatives duly authorized to execute the same.

DUPAGE WATER COMMISSION

ATTEST:

By: _____
John Spatz
General Manager

Carolyn Johnson
Clerk

VILLAGE OF BARTLETT

ATTEST:

By: _____
Its: _____

By: _____

Its: _____

STATE OF ILLINOIS)
) SS
COUNTY OF _____)

I, _____, a Notary Public in and for said County, in the State aforesaid, do hereby certify that _____, personally known to me to be the _____ of the Village of Bartlett, and _____, personally known to me to be the _____ of the Village of Bartlett, and personally known to be the same persons whose names are subscribed to the foregoing instrument, appeared before me this day in person and acknowledged that they signed, sealed, and delivered said instrument as their free and voluntary act, and as the free and voluntary act of said County, for the uses and purposes therein set forth.

Given under my hand and official seal this _____ day of _____, 2017.

Notary Public

My Commission Expires: _____

STATE OF ILLINOIS)
) SS
VILLAGE OF BARTLETT)

I, _____, a Notary Public in and for said County, in the State aforesaid, do hereby certify that John Spatz, personally known to me to be the General Manager of the DuPage Water Commission, and personally known to me to be the same person whose name is subscribed to the foregoing instrument, appeared before me this day in person and acknowledged that he signed, sealed, and delivered said instrument as his free and voluntary act, and as the free and voluntary act of said Commission, for the uses and purposes therein set forth.

Given under my hand and official seal this _____ day of _____, 2017.

Notary Public

My Commission Expires: _____

EXHIBIT E TO
EXECUTION COPY

EXHIBIT E

ILLUSTRATIVE CALCULATION OF
CAPITAL COST RECOVERY CHARGE

DuPage Water Commission
 Calculation of Capital Cost Recovery Charge as of December 31, 2016
 For the Village of Bartlett

Fixed Assets (Audited as of 04-30-2016)		
Land		\$ 11,728,902
Infrastructure		364,135,069
Buildings		103,814,368
Office Equipment		4,658,064
Machinery		20,059,385
Vehicles		669,448
CIP		941,386
Total		\$ 506,006,622
Less: Feeder Mains & Meter Stations		93,293,501
Total		412,713,121
Less: Total Rebates		106,326,287
Total		\$ 306,386,834

Total Capital Cost
 Recovery Charge

Village of Bartlett (CY2015-CY2016 as reported)	3.151	
DuPage Water Commission (CY2015-CY2016 Avg)	70.942	
Total	74.093	
		4.253% \$ 13,030,632

MGD

BARTLETT PUBLIC WATER SUPPLY										
WATER PRODUCTION SUMMARY										
For: 2015										
WATER PRODUCED										
DATE	WELL #1	WELL #2	WELL #4	WELL #5	WELL #6	WELL #7	WELL #8	ALL WELLS	LAKE ST	TOTAL
Jan								TOTAL		
Avg / Day	52,806	52,806	540,806	0	568,710	14,000	0	1,228,129	1,892,345	2,921,474
Max / Day	149,000	149,000	732,000	0	1,017,000	114,000	0	1,544,000	1,791,600	3,330,800
Month Total	1,637,000	1,637,000	16,765,000	0	17,630,000	434,000	0	38,103,000	52,482,700	90,585,700
Feb										
Avg / Day	61,839	61,839	694,250	0	522,107	14,321	0	1,264,367	1,671,829	2,926,196
Max / Day	171,500	171,500	1,294,000	0	822,000	130,000	0	2,030,000	1,784,700	3,772,100
Month Total	1,731,500	1,731,500	16,638,000	0	14,619,000	401,000	0	35,122,000	46,811,200	81,933,200
Mar										
Avg / Day	56,018	56,018	512,710	0	510,194	45,606	0	1,180,742	1,680,590	2,861,332
Max / Day	146,000	146,000	663,000	0	957,000	1,035,000	0	1,760,000	1,789,200	3,376,900
Month Total	1,736,500	1,736,500	15,894,000	0	15,816,000	1,420,000	0	36,803,000	52,098,300	88,701,300
Apr										
Avg / Day	83,900	83,900	579,367	0	515,533	278,167	0	1,540,867	1,827,713	3,368,560
Max / Day	211,000	211,000	1,086,000	0	895,000	1,030,000	0	2,456,000	2,110,900	4,415,800
Month Total	2,617,000	2,617,000	17,381,000	0	15,466,000	8,345,000	0	46,226,000	54,831,400	101,057,400
May										
Avg / Day	59,935	59,935	1,110,613	0	117,181	169,668	0	1,517,613	1,704,287	3,221,900
Max / Day	164,000	164,000	1,642,000	0	526,000	549,000	0	1,977,000	2,653,200	4,420,200
Month Total	1,858,000	1,858,000	34,428,000	0	3,632,000	5,289,000	0	47,046,000	62,832,800	99,878,900
Jun										
Avg / Day	45,533	45,533	1,063,300	0	93,033	231,200	0	1,478,600	1,694,200	3,172,800
Max / Day	190,500	190,500	1,606,000	0	456,000	556,000	0	1,995,000	2,023,300	3,619,700
Month Total	1,366,000	1,366,000	31,899,000	0	2,791,000	6,938,000	0	44,358,000	50,826,000	95,184,000
Jul										
Avg / Day	50,871	50,871	788,871	0	271,968	335,419	0	1,508,000	1,979,203	3,487,203
Max / Day	128,500	128,500	1,633,000	0	1,386,000	831,000	0	2,408,000	2,875,300	4,745,300
Month Total	1,577,000	1,577,000	24,765,000	0	8,431,000	10,398,000	0	46,748,000	61,355,300	108,103,300
Aug										
Avg / Day	17,032	17,032	724,355	0	62,868	294,484	0	1,115,871	2,656,485	3,772,335
Max / Day	70,000	70,000	1,598,000	0	892,000	833,000	0	1,738,000	2,921,400	4,484,700
Month Total	528,000	528,000	22,455,000	0	1,852,000	9,129,000	0	34,592,000	82,350,400	116,942,400
Sep										
Avg / Day	25,683	25,683	705,033	0	44,200	88,533	0	889,133	2,452,860	3,341,993
Max / Day	105,500	105,500	1,281,000	0	206,000	704,000	0	1,536,000	2,724,600	4,159,200
Month Total	770,500	770,500	21,151,000	0	1,326,000	2,656,000	0	26,674,000	73,565,800	100,269,800
Oct										
Avg / Day	48,355	48,355	740,323	0	70,548	144,097	0	1,051,677	1,978,677	3,030,355
Max / Day	208,500	208,500	1,301,000	0	1,135,000	754,000	0	1,681,000	2,437,700	4,072,400
Month Total	1,499,000	1,499,000	22,850,000	0	2,187,000	4,467,000	0	32,602,000	61,339,000	93,941,000
Nov										
Avg / Day	36,050	36,050	839,900	0	0	167,800	0	1,078,800	1,718,377	2,798,177
Max / Day	99,500	99,500	1,196,000	0	0	693,000	0	1,407,000	1,908,100	3,158,100
Month Total	1,081,500	1,081,500	25,197,000	0	0	5,034,000	0	32,394,000	61,681,300	83,945,300
Dec										
Avg / Day	32,371	32,371	448,774	0	0	41,968	0	555,484	2,258,377	2,813,861
Max / Day	88,500	88,500	1,011,000	0	0	478,000	0	1,423,000	2,612,400	3,163,300
Month Total	1,003,500	1,003,500	13,912,000	0	0	1,301,000	0	17,220,000	70,008,700	87,229,700
For: 2015										
Avg / Day	47,412	47,412	721,745	0	229,728	162,849	0	1,199,145	1,945,353	3,144,499
Max / Day	211,000	211,000	1,642,000	0	1,366,000	1,035,000	0	2,456,000	2,921,400	4,745,300
Year Total	17,305,500	17,305,500	263,437,000	0	83,850,000	65,790,000	0	437,688,000	710,054,000	1,147,742,000

**BARTLETT PUBLIC WATER SUPPLY
WATER PRODUCTION SUMMARY
For: 2016**

WATER PRODUCED										
DATE	WELL# 1	WELL# 2	WELL# 4	WELL# 5	WELL# 6	WELL# 7	WELL# 8	ALL WELLS	LAKE ST	TOTAL
								TOTAL		PRODUCED
Jan										
Avg / Day	54,581	54,581	822,903	0	0	15,290	0	947,355	1,985,187	2,932,542
Max / Day	122,000	122,000	1,150,000	0	0	237,000	0	1,316,000	2,710,800	3,287,700
Month Totals	1,692,000	1,692,000	25,610,000	0	0	474,000	0	29,368,000	61,540,800	90,908,800
Feb										
Avg / Day	60,293	60,293	835,103	0	0	8,968	0	964,655	1,880,579	2,845,234
Max / Day	98,000	98,000	1,183,000	0	0	82,000	0	1,288,000	1,919,400	3,094,400
Month Totals	1,748,500	1,748,500	24,218,000	0	0	260,000	0	27,976,000	64,636,800	82,611,800
Mar										
Avg / Day	72,887	72,887	665,581	0	0	6,774	0	818,129	1,984,255	2,802,384
Max / Day	184,500	184,500	1,176,000	0	0	55,000	0	1,444,000	2,287,600	3,355,900
Month Totals	2,289,500	2,289,500	20,633,000	0	0	210,000	0	25,382,000	61,611,900	86,873,900
Apr										
Avg / Day	58,833	58,833	908,733	0	0	144,567	0	1,170,967	2,154,513	3,325,480
Max / Day	228,500	228,500	1,585,000	0	0	466,000	0	2,450,000	2,358,400	4,680,900
Month Totals	1,765,000	1,765,000	27,262,000	0	0	4,337,000	0	35,129,000	64,636,400	99,764,400
May										
Avg / Day	40,565	40,565	341,258	0	471,452	42,032	0	935,871	2,343,632	3,279,503
Max / Day	155,500	155,500	1,207,000	0	994,000	499,000	0	1,486,000	2,653,200	3,921,200
Month Totals	1,267,500	1,267,500	10,679,000	0	14,616,000	1,303,000	0	29,012,000	72,662,600	101,664,800
Jun										
Avg / Day	84,867	84,867	611,033	0	359,567	11,800	0	1,152,133	2,290,200	3,442,333
Max / Day	166,500	166,500	1,314,000	0	694,000	173,000	0	2,075,000	2,387,600	4,189,600
Month Totals	2,646,000	2,646,000	18,331,000	0	10,787,000	364,000	0	34,684,000	68,706,000	103,270,000
Jul										
Avg / Day	73,210	73,210	705,516	0	381,903	56,710	0	1,290,548	2,358,390	3,648,938
Max / Day	181,500	181,500	1,282,000	0	763,000	521,000	0	2,372,000	2,475,900	4,705,000
Month Totals	2,269,500	2,269,500	21,871,000	0	11,839,000	1,788,000	0	40,007,000	73,110,100	113,117,100
Aug										
Avg / Day	76,516	76,516	729,516	0	487,129	4,806	0	1,374,484	2,184,277	3,558,761
Max / Day	253,500	253,500	1,474,000	0	763,000	53,000	0	2,383,000	2,417,500	4,476,900
Month Totals	2,372,000	2,372,000	22,616,000	0	15,101,000	149,000	0	42,609,000	67,712,600	110,321,600
Sep										
Avg / Day	70,833	70,833	588,300	0	494,267	13,133	0	1,235,367	1,984,860	3,220,027
Max / Day	252,500	252,500	803,000	0	747,000	239,000	0	1,763,000	2,303,800	3,918,800
Month Totals	2,125,000	2,125,000	17,589,000	0	14,828,000	394,000	0	37,061,000	69,638,800	86,600,800
Oct										
Avg / Day	59,887	59,887	420,258	0	367,000	5,097	0	902,129	2,076,203	2,978,332
Max / Day	268,000	268,000	924,000	0	712,000	61,000	0	1,610,000	2,273,900	3,517,000
Month Totals	1,866,500	1,866,500	13,028,000	0	11,067,000	168,000	0	27,966,000	64,362,300	82,328,300
Nov										
Avg / Day	33,267	33,267	455,500	0	418,400	5,887	0	946,300	1,924,053	2,870,353
Max / Day	111,000	111,000	838,000	0	624,000	63,000	0	1,199,000	2,141,500	3,214,900
Month Totals	998,000	998,000	13,666,000	0	12,662,000	176,000	0	26,389,000	57,721,800	86,110,800
Dec										
Avg / Day	79,774	79,774	651,194	0	487,355	5,290	0	1,303,367	1,678,642	2,982,009
Max / Day	229,500	229,500	1,334,000	0	816,000	101,000	0	1,937,000	1,818,400	3,654,900
Month Totals	2,473,000	2,473,000	20,187,000	0	15,108,000	164,000	0	40,405,000	62,037,900	92,442,900
For: 2016										
Avg / Day	63,832	63,832	643,410	0	289,336	26,604	0	1,087,014	2,071,223	3,168,237
Max / Day	268,000	268,000	1,595,000	0	994,000	621,000	0	2,460,000	2,710,800	4,705,000
Year Total	23,362,500	23,362,500	235,488,000	0	106,897,000	9,737,000	0	397,847,000	768,067,800	1,165,914,800

EXHIBIT F

ILLUSTRATIVE SCHEDULE OF EVENTS

ILLUSTRATIVE SCHEDULE OF EVENTS

2017

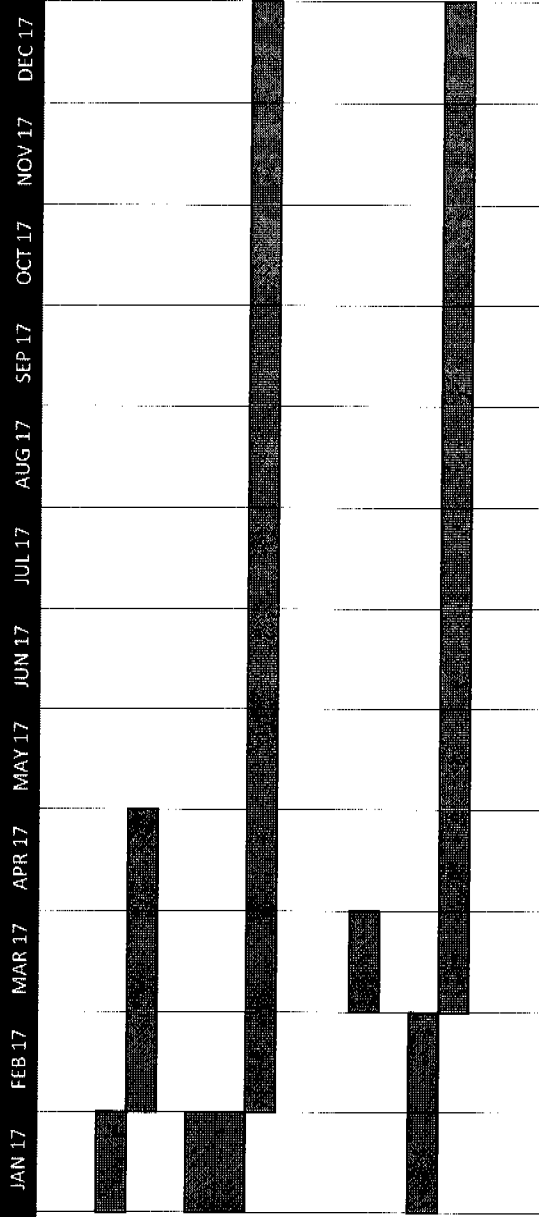

ILLUSTRATIVE SCHEDULE OF EVENTS

2018

	JAN 18	FEB 18	MAR 18	APR 18	MAY 18	JUN 18	JUL 18	AUG 18	SEP 18	OCT 18	NOV 18	DEC 18
I. Bartlett Duties												
A. IDNR Allocation												
B. Bartlett System Connection Facilities												
4. Construction Contract Bid and Award												
5. Construction												
II. DuPage Water Commission Duties												
A. Property Interest												
B. DCW Connection Facilities												
3. Construction Contract Bid and Award												
4. Construction												
III. Other Events												

ILLUSTRATIVE SCHEDULE OF EVENTS

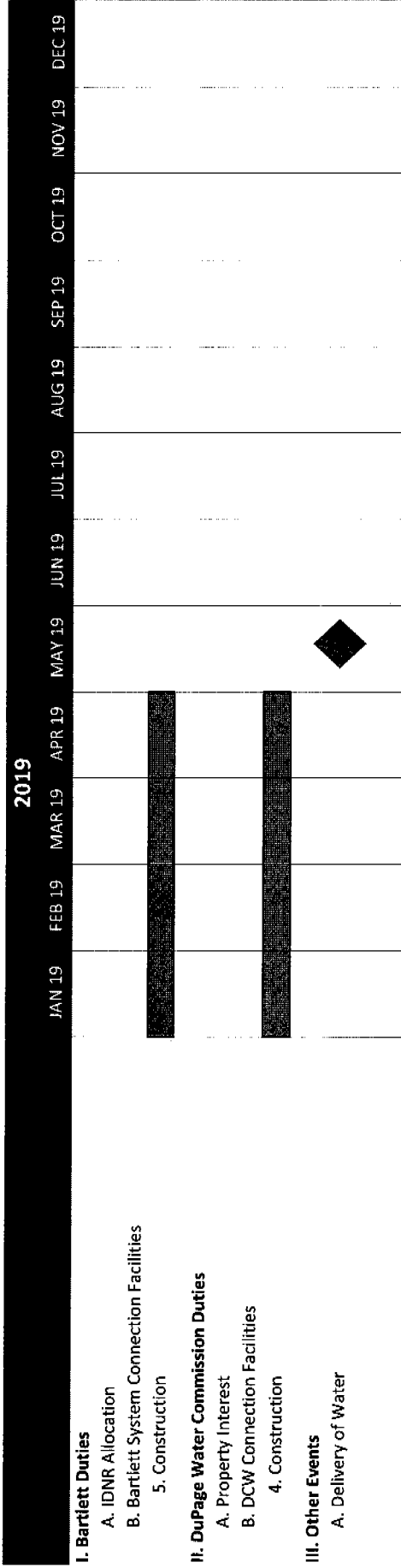

EXHIBIT G

Intergovernmental Agreement Concerning Loan for
Capital Cost Recovery Charge to the Village of Bartlett

INTERGOVERNMENTAL AGREEMENT CONCERNING LOAN FOR CAPITAL COST
RECOVERY CHARGE TO THE VILLAGE OF BARTLETT

THIS AGREEMENT, made and entered into as of this _____ day of February, 2017 ("Effective Date"), by and between the DuPAGE WATER COMMISSION, a county water commission created and existing under the laws of the State of Illinois (the "Commission"), and the VILLAGE OF BARTLETT, a municipal corporation created and existing under the laws of the State of Illinois (the "Village"),

WITNESSETH:

WHEREAS, the Commission was formed and exists pursuant to the Water Commission Act of 1985, 70 ILCS 3720/0.01 *et seq.*, and Division 135 of Article 11 of the Illinois Municipal Code, 65 ILCS 5/11-135-1 *et seq.*, for the purpose of securing an adequate source and supply of water for its customers; and

WHEREAS, the Commission operates a water system supplying a number of municipalities and other customers in DuPage County with water drawn from Lake Michigan; and

WHEREAS, the Village is seeking to obtain water for its residents from the Commission in the incorporated areas within the Village (the "Service Area"); and

WHEREAS, to carry out their duties and responsibilities, and desiring to create a method of providing an adequate supply of Lake Michigan water to the Service Area, the Commission and the Village concurrent with this Agreement are entering into a Water Purchase and Sale Contract dated February , 2017 (the "Enabling Agreement"); and

WHEREAS, to become a member of the Commission and comply with the Enabling Agreement, the Village must pay its proportional share of the costs for all of the property owned by the Commission (the "Capital Cost Recovery Charge") by February 24, 2024; an

WHEREAS, the Village does not currently have, nor does it foresee having, the ability to pay for the Capital Cost Recovery Charge by February 24, 2024; and

WHEREAS, the Commission previously enacted Resolution R-79-04 allowing the Commission the ability to finance the Capital Cost Recovery Charge for potential Subsequent Customers (customers other than Charter Customers) requesting such accommodation on a case-by case basis; and

WHEREAS, the matters set forth in this Agreement will serve the public interest, and the Commission and the Village deem it to be in each of their best interests for the Commission to loan the Village the money necessary to pay the Capital Cost Recovery Charge and enter into this Agreement; and

WHEREAS, pursuant to Section 10 of Article VII of the Illinois Constitution of 1970, the provisions of the Intergovernmental Cooperation Act, 5 ILCS 220/1 *et seq.*, and other applicable authority, the Commission and the Village are authorized to enter into this Agreement;

NOW, THEREFORE, in consideration of the foregoing and the mutual covenants and agreements hereinafter set forth, the Commission and the Village hereby agree as follows:

SECTION 1. PREAMBLES

The foregoing recitals are by this reference incorporated herein and made a part hereof as if fully set forth herein.

SECTION 2. COMMISSION FINANCING

A. Loan. The Commission shall, after the execution and delivery of this Agreement, loan to the Village the amount of \$13,030,632.00 (the "Loan").

B. Loan Repayment.

1. The Village shall repay the principal balance of the Loan in 360 monthly installments, commencing at the time the first payment is due under Subsection 7M in the Enabling Agreement (the "Monthly Payment Date"), and continuing in successive monthly installments on each Monthly Payment Date, with the final payment of any principal, if not sooner paid, on the 360th Monthly Payment Date. Each of the 360 monthly installments of principal on the Loan shall be in the amount of \$36,196.20.

2. Interest on the unpaid principal balance of the Loan, will accrue at the rate of zero percent (0%) per annum.

C. Tender of Loan Payments. Payments of the principal of and interest shall be made in lawful money of the United States of America in federal or other immediately available funds.

D. Application of Loan Proceeds. The proceeds of the Loan shall be paid to the Commission immediately upon receipt as full payment for the Capital Cost Recovery Charge identified in the Enabling Agreement. The parties agree that the amount owed to the Commission for the Capital Cost Recovery Charge is \$13,030,632.

E. Covenants. The covenants sets forth in Subsections 9A, 9B, 9C and 9D of the Enabling Agreement are incorporated into this Agreement by reference.

SECTION 3. DEFAULTS AND REMEDIES

A. Commission Defaults. The occurrence of the following shall constitute a default by the Commission under this Agreement: The failure by the Commission to observe and/or perform any covenant, condition, and/or agreement on its part to be observed and/or performed under this Agreement, and the continuation of said failure for thirty (30) days after the Commission's receipt of written notice thereof from the Village. However, if said failure cannot be remedied by the Commission within said thirty (30) day period, and the Commission shall have diligently pursued the resolution of the failure during said thirty (30) days, the period shall be extended by such additional time as may be reasonably required by the Commission to cure or correct said failure. In no event shall the period be extended by more than ninety (90) days. In the event of a default by the Commission under this Agreement, the Village shall have the same remedies as are provided for, and only the remedies provided for, in the Enabling Agreement for a default by the Commission.

B. Village Defaults. The occurrence of the following shall constitute a default by the Village under this Agreement: The failure by the Village to observe and/or perform any covenant, condition, and/or agreement on its part to be observed and/or performed under this Agreement, and the continuation of said failure for thirty (30) days after the Village's receipt of written notice thereof from the Commission. However, if said failure cannot be remedied by the Village within said thirty (30) day period, and the Village shall have diligently pursued the resolution of the failure during said thirty (30) days, the period shall be extended by such additional time as may be reasonably required by the Village to cure or correct said failure. In no event shall the period be extended by more than ninety (90) days. In the event of a default by the Village under

this Agreement, the Commission shall have the same remedies as are provided for, and only the remedies provided for, in the Enabling Agreement for a default by the Village.

C. Force Majeure. In case by reason of a force majeure event, either party to this Agreement shall be rendered unable wholly or in part to carry out its obligation under this Agreement, then if such party shall give notice and full particulars of such force majeure event in writing to the other party within a reasonable time after occurrence of the event or cause relied on, the obligation of the party giving such notice, so far as it is affected by such force majeure event, shall be suspended during the continuance of the inability then claimed, but for no longer period, and any such party shall endeavor to remove or overcome such inability with all reasonable dispatch. The term "force majeure event" as employed in this Agreement shall mean acts of God, strikes, lockouts, or other industrial disturbances, acts of public enemy, orders of any kind of the Government of the United States, of the State of Illinois, or of any civil or military authority, insurrections, riots, epidemics, landslides, lightning, earthquakes, fires, hurricanes, storms, floods, washouts, droughts, arrests, restraints of government and people, civil disturbances, explosions, breakage or accidents to machinery, pipelines, canals, or tunnels, partial or entire failure of water supply, and inability on the part of the Commission or of the Village to deliver Lake Michigan water, or of the Village to receive Lake Michigan water, on account of any other causes not reasonably within the control of the party claiming such inability. The settlement of strikes and lockouts shall be entirely within the discretion of the party having the difficulty and the above requirement that any "force majeure event" shall be remedied with all reasonable dispatch shall not require the settlement of strikes and lockouts by acceding to the

demands of the opposing party or parties when such settlement is unfavorable to it in the judgment of the party having the difficulty.

SECTION 4. LEGAL RELATIONSHIPS AND REQUIREMENTS

A. Supplemental Agreement. This Agreement shall be deemed to supplement the Enabling Agreement in connection with the supply of Lake Michigan water to the Service Area. If there is any other conflict or inconsistency between the terms of this Agreement and the terms of the Enabling Agreement, then the terms of this Agreement shall control. The Village shall at all times comply with all terms and conditions of the Enabling Agreement, except as otherwise provided in this Agreement.

B. Term of Agreement. This Agreement shall continue in full force and effect from the Effective Date until the Loan is paid in full by the Village.

C. Cooperation and Further Agreements. The Commission and the Village agree to cooperate in good faith throughout the term of this Agreement to implement the letter and spirit of the provisions set forth in this Agreement.

D. Assignment. This Agreement may not be assigned by any party, in whole or in part, without the prior written consent of the other party.

E. Notices. All notices required or permitted to be given under this Agreement shall be in writing and shall be deemed received by the addressee thereof when delivered in person on a business day at the address set forth below or on the third business day after being deposited in any main or branch United States post office, for delivery at the address set forth below by properly addressed, postage prepaid, certified or registered mail, return receipt requested.

Notices and communications to the Commission shall be addressed to, and delivered at, the following address:

DuPage Water Commission
600 East Butterfield Road
Elmhurst, Illinois 60126-4642
Attention: General Manager

Notices and communications to the Village shall be addressed to, and delivered at, the following address:

Village of Bartlett
228 S. Main Street
Bartlett, Illinois 60103
Attention: Village Manager

By notice complying with the requirements of this Section 4.E, the Commission and the Village each shall have the right to change the address or addressee or both for all future notices to it, but no notice of a change of address shall be effective until actually received.

F. No Oral Agreements. No oral agreements exist by or between the Commission and the Village with respect to this Agreement, nor was the making and execution of this Agreement induced by any representation, statement, warranty, agreement, or action other than those expressed or explicitly referenced in this Agreement.

G. No Waiver. No course of dealing or failure of the Commission or the Village to enforce strictly any term, right, or condition of this Agreement shall be construed as a waiver of such term, right, or condition. No express waiver of any term, right, or condition of this Agreement shall operate as a waiver of any other term, right, or condition.

H. No Third Party Beneficiaries. This Agreement is entered into solely for the benefit of the contracting parties, and nothing in this Agreement is intended, either expressly or impliedly, to provide any right or benefit of any kind whatsoever to any

person or entity who is not a party to this Agreement, or to acknowledge, establish, or impose any legal duty to any third party.

I. Governing Law and Venue. This Agreement shall be governed by and construed exclusively under the applicable laws, but not the conflict of laws rules, of the State of Illinois. Venue for any litigation arising out of this Agreement shall only be proper in the Eighteenth Judicial Circuit Court, DuPage County, Illinois.

J. Counterparts. This Agreement may be executed in several counterparts, each of which shall be deemed to be an original, and all of which shall constitute but one and the same instrument. Any such counterpart may be signed by one or more of the parties hereto so long as each of the parties hereto has signed one or more of such counterparts.

IN WITNESS WHEREOF, the Commission and the Village have caused this Agreement to be executed by their duly authorized officers, pursuant to proper authorization of their respective governing bodies, as of the date first stated above.

ATTEST:

DuPAGE WATER COMMISSION

By: _____

By: _____

Its: _____

Its: _____

ATTEST:

VILLAGE OF BARTLETT

By: _____

By: _____

Its: _____

Its: _____

EXHIBIT H

**Intergovernmental Agreement Concerning Loan for
Connection Facilities to Implement Water Service to the
Village of Bartlett**

INTERGOVERNMENTAL AGREEMENT CONCERNING THE LOAN FOR
CONNECTION FACILITIES TO IMPLEMENT WATER SERVICE TO THE VILLAGE OF
BARTLETT

THIS AGREEMENT, made and entered into as of this _____ day of February, 2017 ("Effective Date"), by and between the DuPAGE WATER COMMISSION, a county water commission created and existing under the laws of the State of Illinois (the "Commission"), and the VILLAGE OF BARTLETT, a municipal corporation created and existing under the laws of the State of Illinois (the "Village"),

WITNESSETH:

WHEREAS, the Commission was formed and exists pursuant to the Water Commission Act of 1985, 70 ILCS 3720/0.01 *et seq.*, and Division 135 of Article 11 of the Illinois Municipal Code, 65 ILCS 5/11-135-1 *et seq.*, for the purpose of securing an adequate source and supply of water for its customers; and

WHEREAS, the Commission operates

a water system supplying a number of municipalities and other customers in DuPage County with water drawn from Lake Michigan; and

WHEREAS, the Village is seeking to obtain water for its residents from the Commission in the incorporated areas within the Village (the "Service Area"); and

WHEREAS, the construction of certain improvements to the Commission's Water System will enable the Village to provide water to the Service Area (the "Improvements"); and

WHEREAS, to carry out their duties and responsibilities, and desiring to create a method of providing an adequate supply of Lake Michigan water to the Service Area,

the Commission and the Village concurrent with this Agreement are entering into a Water Purchase and Sale Contract dated February _____, 2017 (the "Enabling Agreement"); and

WHEREAS, it is in the best interests of the Commission and the Village to coordinate and implement the supply of Lake Michigan water to the Service Area in accordance with the Enabling Agreement; and

WHEREAS, the Commission previously enacted Resolution R-79-04 allowing the Commission the ability to finance the Capital Facilities Cost for potential Subsequent Customers (customers other than Charter Customers) requesting such accommodation on a case-by case basis; and

WHEREAS, the Commission and the Village desire to set forth their understanding regarding such coordination and implementation in this Agreement; and

WHEREAS, the matters set forth in this Agreement will serve the public interest and assure that the residents the Service Area are provided safe water to the greatest extent possible; and

WHEREAS, pursuant to Section 10 of Article VII of the Illinois Constitution of 1970, the provisions of the Intergovernmental Cooperation Act, 5 ILCS 220/1 *et seq.*, and other applicable authority, the Commission and the Village are authorized to enter into this Agreement;

NOW, THEREFORE, in consideration of the foregoing and the mutual covenants and agreements hereinafter set forth, the Commission and the Village hereby agree as follows:

SECTION 1. INCORPORATION OF PREAMBLES AND DEFINITIONS FROM ENABLING AGREEMENT

The foregoing recitals are by this reference incorporated herein and made a part hereof as if fully set forth herein. Further, to the extent any capitalized terms in this Agreement are set forth as a defined term in the Enabling Agreement, the capitalized terms in this Agreement shall have the same meaning in this Agreement as the definition in the Enabling Agreement.

SECTION 2. CONSTRUCTION OF IMPROVEMENTS; EXTENSION OF SERVICE

A. Description of the Connection Facilities. For purposes of this Agreement, the Connection Facilities shall include the water mains, metering station and appurtenances necessary to be built by the Commission to provide water to the Village, including portions of the Waterworks System constructed by the Commission to initially connect the Bartlett Unit System to the Commission's existing Waterworks System as depicted in preliminary plans attached to the Enabling Agreement as Exhibits B-1 and B-2.

B. Design of the Connection Facilities. The Commission shall be the contracting party with the design engineer and shall administer the design contract for the benefit of both the Commission and the Village for the Connection Facilities. The Commission shall keep the Village advised as to the progress of the design work. The Commission and the Village shall confer upon issues regarding the details of such design work. The final design of the Connection Facilities shall be subject to the review of both the Commission and the Village and subject to the approval of the Village.

C. Land Acquisition. The Commission shall be responsible for the acquisition and divestment of lands, easements, and rights of way over lands and waters

necessary for the construction, installation, removal, relocation, replacement and extension or improvements of the Connection Facilities outside the corporate limits of the Village of Bartlett and all administrative, title, surveying, and legal fees, costs and expenses associated therewith, including, if necessary, exercising the power of eminent domain to procure any necessary easements, which expenses shall be added to the loan amount that Bartlett shall repay the Commission. The Commission shall keep the Village advised of all land acquisition costs and any necessary condemnation proceedings. All land acquired and costs associated therewith within the Village of Bartlett shall be the sole responsibility of the Village and shall not be paid out of the Loan Commitment.

D. Construction and Acceptance of the Connection Facilities. The Commission shall solicit bids for the construction of the Connection Facilities. The Commission's standard form of bidding and construction contract documents shall be used. The Commission shall solicit, award, and administer all contracts for the project in the best interest of both the Commission and the Village and shall consult with, and keep advised, Village officials regarding the progress of the work and any problems encountered or changes recommended. The Commission, after receiving the written consent of the Village to do so, once the winning contractor and the construction cost have been determined, shall enter into a construction contract(s) with the selected contractor(s), and shall administer such construction contract(s) in conformance with this Agreement. Any change order, as well as final acceptance and approval of the completed Connection Facilities, shall be subject to the final approval of the Commission.

E. Connection Facilities Cost. In accordance with Section 3 of this Agreement, the Commission shall loan the Village funds needed for the Connection Facilities Cost, except for the acquisition of real property and easements within the Village of Bartlett, up to the amount of the Commitment Amount as that term is hereinafter defined, and the Village agrees to reimburse the Commission for those costs.

F. Possible Shortfall. To the extent the Loan Commitment is determined to be insufficient to pay the Connection Facilities Cost, Section 7C of the Enabling Agreement shall apply.

SECTION 3. COMMISSION FINANCING

A. Loan. The Commission shall, after the execution and delivery of this Agreement, make available as a loan to the Village an amount of not to exceed \$21,000,000 (the "Commitment Amount") to pay the Connection Facilities Cost as defined in the Enabling Agreement. The actual moneys borrowed by the Village pursuant to the Commitment Amount will constitute the "Loan".

B. Loan Repayment.

1. The Village shall repay the principal balance of the Loan, plus accrued and unpaid interest at the Interest Rate set forth in Subsection 3.B.2 of this Agreement from the Interest Commencement Date through the Loan Payment Commencement Date (the "Capitalized Interest"), as those terms are hereinafter defined on the unpaid principal balance, and any Capitalized Interest, of the Loan from and after the Loan Payment Commencement Date, as that term is hereinafter defined, in 240

monthly installments, commencing on the 10th day of every month (the "Monthly Payment Date") commencing on the Loan Payment Commencement Date, and continuing in successive monthly installments on each Monthly Payment Date in each month thereafter, with the final payment of any unpaid interest and principal, if not sooner paid, on the 240th Monthly Payment Date. Each of the 240 monthly installments of principal on the Loan shall be determined as of the last day of the month preceding the Monthly Payment Date in any given year during the term of the Loan (a "Principal Determination Date") and shall be determined by dividing the unpaid principal balance, and any Capitalized Interest, of the Loan as of the applicable Principal Determination Date by the number of monthly installments of principal remaining to be paid during the term of the Loan. This monthly payment shall be considered the Connection Facilities Cost Payment as set forth in the Enabling Agreement. The accrued and unpaid interest shall be capitalized on a monthly basis until the Loan Payment Commencement Date.

2. Interest on the unpaid principal balance, and any Capitalized Interest, of the Loan shall accrue at a rate (the "Interest Rate") which is the lesser of: (i) the highest monthly average yield to maturity interest rate earned by the Commission (total all funds) as reported monthly on the Commission's Schedule of Investments for the immediately preceding fiscal year (May 1 – April 30) as

determined by the Commission (the "Earned Interest Rate") plus one per cent (1%); or (ii) four per cent (4%) per annum. Interest shall only accrue on moneys actually borrowed under Subsection 3D of this Agreement, and shall begin to accrue when the Commission makes its first draw on the loan for the Village (the "Interest Commencement Date"). The Interest Rate for each year that the Loan remains outstanding shall be calculated on the basis of a calendar year consisting of 360 days of twelve 30-day months and shall be adjusted on May 1st of each year, and shall be applied to the outstanding unpaid principal balance, and any Capitalized Interest, as determined on the most recent Principal Determination Date, shall be paid commencing on the Monthly Payment Date, and continuing on the Monthly Payment Date each month thereafter until the principal balance of the Loan and all interest thereon has been paid in full.

3. Payments of principal and interest, including Capitalized Interest, shall begin on the earlier of January 10, 2020 or the 10th day of the first month after the first delivery of potable, filtered water drawn from Lake Michigan to the Bartlett Unit System as that term is defined in the Enabling Agreement (the "Loan Payment Commencement Date").

C. Tender of Loan Payments. Payments of the principal of and interest shall be made in lawful money of the United States of America in federal or other immediately available funds.

D. Procedure for Borrowing. Upon the Commission's receipt of invoices incurred arising out of the Connection Facilities Cost as that term is defined in the Enabling Agreement, the Commission shall pay the actual costs incurred from the Connection Facilities Cost. The Commission payments for the Connection Facilities Cost shall be paid out of the Commitment Amount and will be immediately considered part of the Loan. The Commission may make payments from the Loan no more than once per month, on the 10th day of the month, provided that the Commission shall give the Village irrevocable notice (which notice must be received by the Village prior to 10:00 a.m., local time, 7 days prior to the requested borrowing date), specifying the amount to be paid and the payment date. It is anticipated that only a single borrowing shall be requested each month. Each borrowing pursuant to this Agreement shall be in an aggregate principal amount less than the Available Commitment. For purposes of this Section 3.D, the Available Commitment at a particular time is an amount equal to the difference between the Commitment Amount and the aggregate principal balance of the Loan then outstanding.

E. Optional Prepayments. Subject to the limitations of this Section 3.E, the Village may, no more frequently than once in any given year, prepay, in whole or in part, the Loan, without premium or penalty, upon at least one business day's irrevocable notice to the Commission, specifying the date and amount of prepayment. The amount of any such optional prepayment shall be in increments of \$50,000. If such notice is given, the Village shall make such prepayment and the payment amount specified in such notice shall be due and payable on the date specified therein. The proceeds of any such prepayment shall be applied by the Commission first, to the payment of accrued and unpaid interest, if any, on the Loan and second, to the payment of the

unpaid principal balance of the Loan. The Village shall not be entitled to, nor receive any credit for, interest on any such prepayment.

F. Application of Loan Proceeds. The proceeds of the Loan shall be devoted to and used with due diligence for the purpose of paying the Connection Facilities Cost identified in Exhibit A; provided, however, that where an unexpended balance remains in any one or more of the various cost components of the Connection Facilities Cost detailed in Exhibit A attached hereto, such balance may be transferred and expended, in whole or in part, to and for any other cost component of the Connection Facilities Cost detailed in Exhibit A attached hereto.

G. Covenants. The Covenants set forth in Subsections 9A, 9B, 9C and 9D of the Enabling Agreement are incorporated into this Agreement by reference.

SECTION 4. DEFAULTS AND REMEDIES

A. Commission Defaults. The occurrence of the following shall constitute a default by the Commission under this Agreement: The failure by the Commission to observe and/or perform any covenant, condition, and/or agreement on its part to be observed and/or performed under this Agreement, and the continuation of said failure for thirty (30) days after the Commission's receipt of written notice thereof from the Village. However, if said failure cannot be remedied by the Commission within said thirty (30) day period, and the Commission shall have diligently pursued the resolution of the failure during said thirty (30) days, the period shall be extended by such additional time as may be reasonably required by the Commission to cure or correct said failure. In no event shall the period be extended by more than ninety (90) days. In the event of a default by the Commission under this Agreement, the Village shall have the same

remedies as are provided for, and only the remedies provided for, in the Enabling Agreement for a default by the Commission.

B. Village Defaults. The occurrence of the following shall constitute a default by the Village under this Agreement: The failure by the Village to observe and/or perform any covenant, condition, and/or agreement on its part to be observed and/or performed under this Agreement, and the continuation of said failure for thirty (30) days after the Village's receipt of written notice thereof from the Commission. However, if said failure cannot be remedied by the Village within said thirty (30) day period, and the Village shall have diligently pursued the resolution of the failure during said thirty (30) days, the period shall be extended by such additional time as may be reasonably required by the Village to cure or correct said failure. In no event shall the period be extended by more than ninety (90) days.

In the event of a default by the Village, the Commission shall: (i) be paid its reasonable attorneys' fees and costs incurred in connection with that default, in addition to any attorneys' fees and costs incurred in enforcing the terms of this Agreement; (2) be entitled to the right to enforce a lien against all income derived from the Bartlett Unit System, other than that income necessary to pay any loans to the State of Illinois or its agencies for the construction of the Bartlett Unit System, until the Loan is paid back in full; and (3) shall have the same remedies as are provided for in the Enabling Agreement for a default by the Village.

C. Force Majeure. In case by reason of a force majeure event, either party to this Agreement shall be rendered unable wholly or in part to carry out its obligation under this Agreement, then if such party shall give notice and full particulars of such force majeure event in writing to the other party within a reasonable time after

occurrence of the event or cause relied on, the obligation of the party giving such notice, so far as it is affected by such force majeure event, shall be suspended during the continuance of the inability then claimed, but for no longer period, and any such party shall endeavor to remove or overcome such inability with all reasonable dispatch. The term "force majeure event" as employed in this Agreement shall mean acts of God, strikes, lockouts, or other industrial disturbances, acts of public enemy, orders of any kind of the Government of the United States, of the State of Illinois, or of any civil or military authority, insurrections, riots, epidemics, landslides, lightning, earthquakes, fires, hurricanes, storms, floods, washouts, droughts, arrests, restraints of government and people, civil disturbances, explosions, breakage or accidents to machinery, pipelines, canals, or tunnels, partial or entire failure of water supply, and inability on the part of the Commission or of the Village to deliver Lake Michigan water, or of the Village to receive Lake Michigan water, on account of any other causes not reasonably within the control of the party claiming such inability. The settlement of strikes and lockouts shall be entirely within the discretion of the party having the difficulty and the above requirement that any "force majeure event" shall be remedied with all reasonable dispatch shall not require the settlement of strikes and lockouts by acceding to the demands of the opposing party or parties when such settlement is unfavorable to it in the judgment of the party having the difficulty.

SECTION 5. LEGAL RELATIONSHIPS AND REQUIREMENTS

A. Supplemental Agreement. This Agreement shall be deemed to supplement the Enabling Agreement in connection with the supply of Lake Michigan water to the Service Area. If there is any other conflict or inconsistency between the terms of this Agreement and the terms of the Enabling Agreement, then the terms of

this Agreement shall control. The Village shall at all times comply with all terms and conditions of the Enabling Agreement except as otherwise provided in this Agreement.

B. Term of Agreement. This Agreement shall continue in full force and effect from the Effective Date until the Loan is paid in full by the Village.

C. Cooperation and Further Agreements. The Commission and the Village agree to meet and cooperate in good faith throughout the term of this Agreement to implement the letter and spirit of the provisions set forth in this Agreement.

D. Assignment. This Agreement may not be assigned by any party, in whole or in part, without the prior written consent of the other party.

E. Notices. All notices required or permitted to be given under this Agreement shall be in writing and shall be deemed received by the addressee thereof when delivered in person on a business day at the address set forth below or on the third business day after being deposited in any main or branch United States post office, for delivery at the address set forth below by properly addressed, postage prepaid, certified or registered mail, return receipt requested.

Notices and communications to the Commission shall be addressed to, and delivered at, the following address:

DuPage Water Commission
600 East Butterfield Road
Elmhurst, Illinois 60126-4642
Attention: General Manager

Notices and communications to the Village shall be addressed to, and delivered at, the following address:

Village of Bartlett
228 S. Main Street
Bartlett, Illinois 60103
Attention: Village Manager

By notice complying with the requirements of this Section 5.E, the Commission and the Village each shall have the right to change the address or addressee or both for all future notices to it, but no notice of a change of address shall be effective until actually received.

F. No Oral Agreements. No oral agreements exist by or between the Commission and the Village with respect to this Agreement, nor was the making and execution of this Agreement induced by any representation, statement, warranty, agreement, or action other than those expressed or explicitly referenced in this Agreement.

G. No Waiver. No course of dealing or failure of the Commission or the Village to enforce strictly any term, right, or condition of this Agreement shall be construed as a waiver of such term, right, or condition. No express waiver of any term, right, or condition of this Agreement shall operate as a waiver of any other term, right, or condition.

H. No Third Party Beneficiaries. This Agreement is entered into solely for the benefit of the contracting parties, and nothing in this Agreement is intended, either expressly or impliedly, to provide any right or benefit of any kind whatsoever to any person or entity who is not a party to this Agreement, or to acknowledge, establish, or impose any legal duty to any third party.

I. Governing Law and Venue. This Agreement shall be governed by and construed exclusively under the applicable laws, but not the conflict of laws rules, of the State of Illinois. Venue for any litigation arising out of this Agreement shall only be proper in the Eighteenth Judicial Circuit Court, DuPage County, Illinois.

J. Counterparts. This Agreement may be executed in several counterparts, each of which shall be deemed to be an original, and all of which shall constitute but one and the same instrument. Any such counterpart may be signed by one or more of the parties hereto so long as each of the parties hereto has signed one or more of such counterparts.

IN WITNESS WHEREOF, the Commission and the Village have caused this Agreement to be executed by their duly authorized officers, pursuant to proper authorization of their respective governing bodies, as of the date first stated above.

ATTEST:

DuPAGE WATER COMMISSION

By: _____

By: _____

Its: _____

Its: _____

ATTEST:

VILLAGE OF BARTLETT

By: _____

By: _____

Its: _____

Its: _____

EXHIBIT A

Connection Facilities Cost

DRAFT

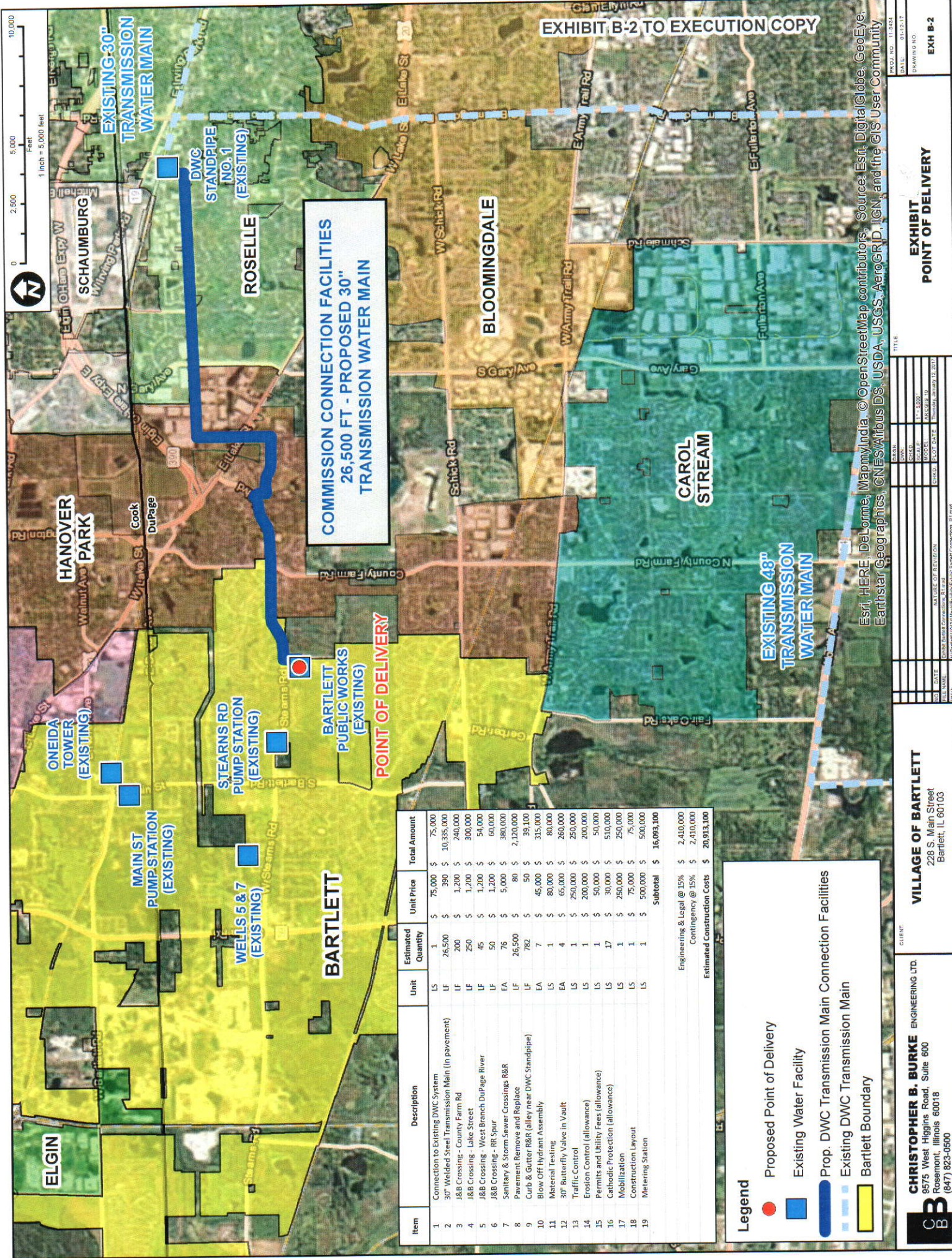

EXHIBIT B-2 TO EXECUTION COPY



**COMMISSION CONNECTION FACILITIES
26,500 FT - PROPOSED 30"
TRANSMISSION WATER MAIN**

POINT OF DELIVERY

Item	Description	Unit	Estimated Quantity	Unit Price	Total Amount
1	Connection to Existing DWG System	LS	1	\$ 75,000	\$ 75,000
2	30" Welded Steel Transmission Main (in pavement)	LF	26,500	\$ 390	\$ 10,335,000
3	J&B Crossing - County Farm Rd	LF	200	\$ 1,200	\$ 240,000
4	J&B Crossing - Lake Street	LF	250	\$ 1,200	\$ 300,000
5	J&B Crossing - West Branch DuPage River	LF	45	\$ 1,200	\$ 54,000
6	J&B Crossing - RR Spur	LF	50	\$ 1,200	\$ 60,000
7	Sanitary & Storm Sewer Crossings R&R	EA	76	\$ 5,000	\$ 380,000
8	Pavement Remove and Replace	LF	26,500	\$ 80	\$ 2,120,000
9	Curb & Gutter R&R (alley near DWG Standpipe)	LF	782	\$ 50	\$ 39,100
10	Blow Off Hydrant Assembly	EA	7	\$ 45,000	\$ 315,000
11	Material Testing	EA	1	\$ 80,000	\$ 80,000
12	30" Butterfly Valve in Vault	EA	4	\$ 65,000	\$ 260,000
13	Traffic Control	LS	1	\$ 250,000	\$ 250,000
14	Erosion Control (allowance)	LS	1	\$ 200,000	\$ 200,000
15	Permits and Utility Fees (allowance)	LS	1	\$ 50,000	\$ 50,000
16	Catholic Protection (allowance)	LS	17	\$ 30,000	\$ 510,000
17	Mobilization	LS	1	\$ 250,000	\$ 250,000
18	Construction Layout	LS	1	\$ 75,000	\$ 75,000
19	Metering Station	LS	1	\$ 500,000	\$ 500,000
				Subtotal	\$ 16,093,100
				Engineering & Legal @ 15%	\$ 2,410,000
				Contingency @ 15%	\$ 2,410,000
				Estimated Construction Costs	\$ 20,913,100

Legend

- Proposed Point of Delivery
- Existing Water Facility
- Prop. DWG Transmission Main Connection Facilities
- Existing DWG Transmission Main
- Bartlett Boundary

CHRISTOPHER B. BURKE ENGINEERING, LTD.
9575 West Higgins Road, Suite 800
Rosemont, Illinois 60018
(847) 823-0500

VILLAGE OF BARTLETT
228 S. Main Street
Bartlett, IL 60103

CLIENT

FILE NAME:	PROJECT:	DATE:	SCALE:
PROJECT NO. 11-0024	11-0002	ANCORE 10	1" = 5,000'
DRAWING NO. EXH B-2	DATE:	PROJECT DATE:	REVISION:

**EXHIBIT
POINT OF DELIVERY**

Esri, HERE, DeLorme, MapmyIndia, © OpenStreetMap contributors, Source: Esri, DigitalGlobe, GeoEye, Earthstar Geographics, CNES/Airbus DS, USDA, USGS, AeroGRID, IGN, and the GIS User Community

DATE: January 12, 2017

REQUEST FOR BOARD ACTION

AGENDA SECTION	Administration Committee	ORIGINATING DEPARTMENT	General Manager's Office
ITEM	An Ordinance Approving and Authorizing the Execution of an Intergovernmental Agreement Between the DuPage Water Commission and the Village of Bartlett Concerning A Loan for Capital Cost Recovery Charge to the Village of Bartlett Ordinance No. O-2-17	APPROVAL	
Account No.: N/A			
<p>Ordinance No. O-2-17 would authorize and direct the Chairman to execute an Intergovernmental Agreement Concerning a Loan for Capital Cost Recovery Charge to the Village of Bartlett in substantially the form attached in Exhibit A.</p> <p>This Agreement would accommodate the request by the Village of Bartlett for the Commission to finance the capital cost recovery charge (sometimes referred to as buy-in cost).</p> <p>The Loan would be in the amount of \$13,030,632.00 and would be immediately returned as full payment of the capital cost recovery charges per the Water Purchase and Sale Contract between the DuPage Water Commission and the Village of Bartlett.</p> <p>The Loan would be repaid over 360 monthly payments (30 years) at an interest rate of 0% beginning the month after the Village of Bartlett begins receiving water from the Commission.</p>			
MOTION: To approve Ordinance No. O-2-17.			

DUPAGE WATER COMMISSION

ORDINANCE NO. O-2-17

AN ORDINANCE APPROVING AND AUTHORIZING THE EXECUTION OF AN INTERGOVERNMENTAL AGREEMENT BETWEEN THE DUPAGE WATER COMMISSION AND THE VILLAGE OF BARTLETT CONCERNING A LOAN FOR CAPITAL COST RECOVERY CHARGE TO THE VILLAGE OF BARTLETT

WHEREAS, the DuPage Water Commission (the "Commission") was formed and exists pursuant to the Water Commission Act of 1985 (70 ILCS 3720/1 *et seq.*) and Division 11 of Article 135 of the Illinois Municipal Code (65 ILCS 5/11-135-1 *et seq.*) (collectively the "Act") for the purpose of financing, constructing, and operating a water supply system to serve its Charter Customers and other customers in DuPage County with a common source of supply of water from Lake Michigan; and

WHEREAS, the Village of Bartlett ("Bartlett") and the Commission have negotiated an Intergovernmental Agreement Concerning A Loan for Capital Cost Recovery to the Village of Bartlett (the "Capital Cost Recovery Charge Intergovernmental Agreement"), in substantially the form attached hereto and by this reference incorporated herein and made a part of as Exhibit A; and

WHEREAS, prior to or simultaneously with the execution of the Capital Cost Recovery Charge Intergovernmental Agreement, Bartlett and the Commission shall enter into a Water Purchase and Sale Contract for the Bartlett Unit System; and

WHEREAS, the Commission previously enacted Resolution R-79-04 allowing the Commission to finance the Capital Cost Recovery Charge for potential Subsequent Customers on a case-by case basis when a potential Subsequent Customer requests such accommodation and such accommodation would not be contrary to the best interests of the Commission as determined by the Board of Commissioners of the DuPage Water Commission; and

WHEREAS, Bartlett has requested, pursuant to Resolution R-79-04, that the Commission finance Bartlett's Capital Cost Recovery Charge which will be owed under the Water Purchase and Sale Contract for the Bartlett Unit System; and

WHEREAS, the Commission and Bartlett have each determined that it is in their respective best interests to enter into the Capital Cost Recovery Charge Intergovernmental Agreement.

NOW, THEREFORE, BE IT ORDAINED, by the Board of Commissioners of the DuPage Water Commission as follows:

SECTION ONE: The foregoing recitals are hereby incorporated herein as findings of the Board of Commissioners of the DuPage Water Commission.

SECTION TWO: An Intergovernmental Agreement Concerning A Loan for Capital Cost Recovery Charge to the Village of Bartlett, in substantially the form attached hereto as Exhibit A, is hereby approved.

SECTION THREE: The Chairman of the DuPage Water Commission shall be and hereby is authorized to and directed to execute an Intergovernmental Agreement Concerning A Loan for Capital Cost Recovery Charge to the Village of Bartlett in substantially the form attached hereto as Exhibit A; provided, however, that said Intergovernmental Agreement shall not be so executed on behalf of the DuPage Water Commission unless and until the Chairman shall have been presented with copies executed by the Village of Bartlett of the completed Intergovernmental Agreement Concerning A Loan for Capital Cost Recovery Charge and a Water Purchase and Sale Contract in substantially the form previously approved by the Commission.

Ordinance No. O-2-17

SECTION FOUR: Upon execution by the Chairman, the Intergovernmental Agreement Concerning A Loan for Capital Cost Recovery Charge, and all other things provided for therein, shall be deemed accepted by the DuPage Water Commission without further act.

SECTION FIVE: This Ordinance shall be in full force and effect from and after its adoption by a majority affirmative vote of all the Commissioners including the affirmative vote of at least 1/3 of the Commissioners appointed by the County Board Chairman and 40 percent of the Commissioners appointed by the Mayors.

AYES:

NAYS:

ABSENT:

ADOPTED this 19th day of January, 2017

Chairman

ATTEST:

Clerk

EXHIBIT A

INTERGOVERNMENTAL AGREEMENT CONCERNING LOAN FOR CAPITAL COST
RECOVERY CHARGE TO THE VILLAGE OF BARTLETT

THIS AGREEMENT, made and entered into as of this _____ day of February, 2017 (“Effective Date”), by and between the DuPAGE WATER COMMISSION, a county water commission created and existing under the laws of the State of Illinois (the “Commission”), and the VILLAGE OF BARTLETT, a municipal corporation created and existing under the laws of the State of Illinois (the “Village”),

WITNESSETH:

WHEREAS, the Commission was formed and exists pursuant to the Water Commission Act of 1985, 70 ILCS 3720/0.01 *et seq.*, and Division 135 of Article 11 of the Illinois Municipal Code, 65 ILCS 5/11-135-1 *et seq.*, for the purpose of securing an adequate source and supply of water for its customers; and

WHEREAS, the Commission operates a water system supplying a number of municipalities and other customers in DuPage County with water drawn from Lake Michigan; and

WHEREAS, the Village is seeking to obtain water for its residents from the Commission in the incorporated areas within the Village (the “Service Area”); and

WHEREAS, to carry out their duties and responsibilities, and desiring to create a method of providing an adequate supply of Lake Michigan water to the Service Area, the Commission and the Village concurrent with this Agreement are entering into a Water Purchase and Sale Contract dated February , 2017 (the “Enabling Agreement”); and

WHEREAS, to become a member of the Commission and comply with the Enabling Agreement, the Village must pay its proportional share of the costs for all of the property owned by the Commission (the "Capital Cost Recovery Charge") by February 24, 2024; an

WHEREAS, the Village does not currently have, nor does it foresee having, the ability to pay for the Capital Cost Recovery Charge by February 24, 2024; and

WHEREAS, the Commission previously enacted Resolution R-79-04 allowing the Commission the ability to finance the Capital Cost Recovery Charge for potential Subsequent Customers (customers other than Charter Customers) requesting such accommodation on a case-by case basis; and

WHEREAS, the matters set forth in this Agreement will serve the public interest, and the Commission and the Village deem it to be in each of their best interests for the Commission to loan the Village the money necessary to pay the Capital Cost Recovery Charge and enter into this Agreement; and

WHEREAS, pursuant to Section 10 of Article VII of the Illinois Constitution of 1970, the provisions of the Intergovernmental Cooperation Act, 5 ILCS 220/1 *et seq.*, and other applicable authority, the Commission and the Village are authorized to enter into this Agreement;

NOW, THEREFORE, in consideration of the foregoing and the mutual covenants and agreements hereinafter set forth, the Commission and the Village hereby agree as follows:

SECTION 1. PREAMBLES

The foregoing recitals are by this reference incorporated herein and made a part hereof as if fully set forth herein.

SECTION 2. COMMISSION FINANCING

A. Loan. The Commission shall, after the execution and delivery of this Agreement, loan to the Village the amount of \$13,030,632.00 (the "Loan").

B. Loan Repayment.

1. The Village shall repay the principal balance of the Loan in 360 monthly installments, commencing at the time the first payment is due under Subsection 7M in the Enabling Agreement (the "Monthly Payment Date"), and continuing in successive monthly installments on each Monthly Payment Date, with the final payment of any principal, if not sooner paid, on the 360th Monthly Payment Date. Each of the 360 monthly installments of principal on the Loan shall be in the amount of \$36,196.20.
2. Interest on the unpaid principal balance of the Loan, will accrue at the rate of zero percent (0%) per annum.

C. Tender of Loan Payments. Payments of the principal of and interest shall be made in lawful money of the United States of America in federal or other immediately available funds.

D. Application of Loan Proceeds. The proceeds of the Loan shall be paid to the Commission immediately upon receipt as full payment for the Capital Cost Recovery Charge identified in the Enabling Agreement. The parties agree that the amount owed to the Commission for the Capital Cost Recovery Charge is \$13,030,632.

E. Covenants. The covenants sets forth in Subsections 9A, 9B, 9C and 9D of the Enabling Agreement are incorporated into this Agreement by reference.

SECTION 3. DEFAULTS AND REMEDIES

A. Commission Defaults. The occurrence of the following shall constitute a default by the Commission under this Agreement: The failure by the Commission to observe and/or perform any covenant, condition, and/or agreement on its part to be observed and/or performed under this Agreement, and the continuation of said failure for thirty (30) days after the Commission's receipt of written notice thereof from the Village. However, if said failure cannot be remedied by the Commission within said thirty (30) day period, and the Commission shall have diligently pursued the resolution of the failure during said thirty (30) days, the period shall be extended by such additional time as may be reasonably required by the Commission to cure or correct said failure. In no event shall the period be extended by more than ninety (90) days. In the event of a default by the Commission under this Agreement, the Village shall have the same remedies as are provided for, and only the remedies provided for, in the Enabling Agreement for a default by the Commission.

B. Village Defaults. The occurrence of the following shall constitute a default by the Village under this Agreement: The failure by the Village to observe and/or perform any covenant, condition, and/or agreement on its part to be observed and/or performed under this Agreement, and the continuation of said failure for thirty (30) days after the Village's receipt of written notice thereof from the Commission. However, if said failure cannot be remedied by the Village within said thirty (30) day period, and the Village shall have diligently pursued the resolution of the failure during said thirty (30) days, the period shall be extended by such additional time as may be reasonably required by the Village to cure or correct said failure. In no event shall the period be extended by more than ninety (90) days. In the event of a default by the Village under

this Agreement, the Commission shall have the same remedies as are provided for, and only the remedies provided for, in the Enabling Agreement for a default by the Village.

C. Force Majeure. In case by reason of a force majeure event, either party to this Agreement shall be rendered unable wholly or in part to carry out its obligation under this Agreement, then if such party shall give notice and full particulars of such force majeure event in writing to the other party within a reasonable time after occurrence of the event or cause relied on, the obligation of the party giving such notice, so far as it is affected by such force majeure event, shall be suspended during the continuance of the inability then claimed, but for no longer period, and any such party shall endeavor to remove or overcome such inability with all reasonable dispatch. The term "force majeure event" as employed in this Agreement shall mean acts of God, strikes, lockouts, or other industrial disturbances, acts of public enemy, orders of any kind of the Government of the United States, of the State of Illinois, or of any civil or military authority, insurrections, riots, epidemics, landslides, lightning, earthquakes, fires, hurricanes, storms, floods, washouts, droughts, arrests, restraints of government and people, civil disturbances, explosions, breakage or accidents to machinery, pipelines, canals, or tunnels, partial or entire failure of water supply, and inability on the part of the Commission or of the Village to deliver Lake Michigan water, or of the Village to receive Lake Michigan water, on account of any other causes not reasonably within the control of the party claiming such inability. The settlement of strikes and lockouts shall be entirely within the discretion of the party having the difficulty and the above requirement that any "force majeure event" shall be remedied with all reasonable dispatch shall not require the settlement of strikes and lockouts by acceding to the

demands of the opposing party or parties when such settlement is unfavorable to it in the judgment of the party having the difficulty.

SECTION 4. LEGAL RELATIONSHIPS AND REQUIREMENTS

A. Supplemental Agreement. This Agreement shall be deemed to supplement the Enabling Agreement in connection with the supply of Lake Michigan water to the Service Area. If there is any other conflict or inconsistency between the terms of this Agreement and the terms of the Enabling Agreement, then the terms of this Agreement shall control. The Village shall at all times comply with all terms and conditions of the Enabling Agreement, except as otherwise provided in this Agreement.

B. Term of Agreement. This Agreement shall continue in full force and effect from the Effective Date until the Loan is paid in full by the Village.

C. Cooperation and Further Agreements. The Commission and the Village agree to cooperate in good faith throughout the term of this Agreement to implement the letter and spirit of the provisions set forth in this Agreement.

D. Assignment. This Agreement may not be assigned by any party, in whole or in part, without the prior written consent of the other party.

E. Notices. All notices required or permitted to be given under this Agreement shall be in writing and shall be deemed received by the addressee thereof when delivered in person on a business day at the address set forth below or on the third business day after being deposited in any main or branch United States post office, for delivery at the address set forth below by properly addressed, postage prepaid, certified or registered mail, return receipt requested.

Notices and communications to the Commission shall be addressed to, and delivered at, the following address:

DuPage Water Commission
600 East Butterfield Road
Elmhurst, Illinois 60126-4642
Attention: General Manager

Notices and communications to the Village shall be addressed to, and delivered at, the following address:

Village of Bartlett
228 S. Main Street
Bartlett, Illinois 60103
Attention: Village Manager

By notice complying with the requirements of this Section 4.E, the Commission and the Village each shall have the right to change the address or addressee or both for all future notices to it, but no notice of a change of address shall be effective until actually received.

F. No Oral Agreements. No oral agreements exist by or between the Commission and the Village with respect to this Agreement, nor was the making and execution of this Agreement induced by any representation, statement, warranty, agreement, or action other than those expressed or explicitly referenced in this Agreement.

G. No Waiver. No course of dealing or failure of the Commission or the Village to enforce strictly any term, right, or condition of this Agreement shall be construed as a waiver of such term, right, or condition. No express waiver of any term, right, or condition of this Agreement shall operate as a waiver of any other term, right, or condition.

H. No Third Party Beneficiaries. This Agreement is entered into solely for the benefit of the contracting parties, and nothing in this Agreement is intended, either expressly or impliedly, to provide any right or benefit of any kind whatsoever to any

person or entity who is not a party to this Agreement, or to acknowledge, establish, or impose any legal duty to any third party.

I. Governing Law and Venue. This Agreement shall be governed by and construed exclusively under the applicable laws, but not the conflict of laws rules, of the State of Illinois. Venue for any litigation arising out of this Agreement shall only be proper in the Eighteenth Judicial Circuit Court, DuPage County, Illinois.

J. Counterparts. This Agreement may be executed in several counterparts, each of which shall be deemed to be an original, and all of which shall constitute but one and the same instrument. Any such counterpart may be signed by one or more of the parties hereto so long as each of the parties hereto has signed one or more of such counterparts.

IN WITNESS WHEREOF, the Commission and the Village have caused this Agreement to be executed by their duly authorized officers, pursuant to proper authorization of their respective governing bodies, as of the date first stated above.

ATTEST:

DuPAGE WATER COMMISSION

By: _____

By: _____

Its: _____

Its: _____

ATTEST:

VILLAGE OF BARTLETT

By: _____

By: _____

Its: _____

Its: _____

DATE: January 12, 2017

REQUEST FOR BOARD ACTION

AGENDA SECTION	Administration Committee	ORIGINATING DEPARTMENT	General Manager's Office
ITEM	An Ordinance Approving and Authorizing the Execution of An Intergovernmental Agreement Between the DuPage Water Commission and the Village of Bartlett Concerning the Loan for Connection Facilities to Implement Water Service to the Village of Bartlett Ordinance No. O-3-17	APPROVAL	
Account No.: N/A			
<p>Ordinance No. O-3-17 would authorize and direct the Chairman to execute an Intergovernmental Agreement Concerning the Loan for Connection Facilities to Implement Water Service to the Village of Bartlett in substantially the form attached in Exhibit A.</p> <p>This Agreement would accommodate the request by the Village of Bartlett for the Commission to finance the connection facilities cost.</p> <p>The Loan amount would be capped at \$21,000,000.00 (the committed amount). The Commission would draw money from this amount as needed to complete the construction of all charges related to the completion of the connection facilities needed to supply water to the Village of Bartlett.</p> <p>The Loan would be repaid over 240 monthly payments (20 years) at an interest rate of the lower of the highest monthly average yield to maturity interest rate earned by the Commission (total all funds) as reported monthly on the Commission's Schedule of Investments for the immediately preceding fiscal year (May 1 – April 30) as determined by the Commission plus one percent (1%) or four percent (4%) per annum.</p> <p>Interest will begin to be charged as withdrawals from the loan are needed. Interest will be capitalized on a monthly basis until the Village of Bartlett begins making payments on this loan.</p> <p>Loan payments would begin on the earlier of the first month after the Village of Bartlett begins taking water from the Commission or January 10, 2020.</p>			
MOTION: To approve Ordinance No. O-3-17.			

DUPAGE WATER COMMISSION

ORDINANCE NO. O-3-17

AN ORDINANCE APPROVING AND AUTHORIZING THE EXECUTION OF AN INTERGOVERNMENTAL AGREEMENT BETWEEN THE DUPAGE WATER COMMISSION AND THE VILLAGE OF BARTLETT CONCERNING THE LOAN FOR CONNECTION FACILITIES TO IMPLEMENT WATER SERVICE TO THE VILLAGE OF BARTLETT

WHEREAS, the DuPage Water Commission (the "Commission") was formed and exists pursuant to the Water Commission Act of 1985 (70 ILCS 3720/1 *et seq.*) and Division 11 of Article 135 of the Illinois Municipal Code (65 ILCS 5/11-135-1 *et seq.*) (collectively the "Act") for the purpose of financing, constructing, and operating a water supply system to serve its Charter Customers and other customers in DuPage County with a common source of supply of water from Lake Michigan; and

WHEREAS, the Village of Bartlett ("Bartlett") and the Commission and have negotiated an Intergovernmental Agreement Concerning the Loan for Connection Facilities to Implement Water Service to the Village of Bartlett (the "Connection Facilities Loan Intergovernmental Agreement"), in substantially the form attached hereto and by this reference incorporated herein and made a part of as Exhibit A; and

WHEREAS, prior to or simultaneously with the execution of the Connection Facilities Loan Intergovernmental Agreement, Bartlett and the Commission shall enter into a Water Purchase and Sale Contract for the Bartlett Unit System; and

WHEREAS, the Commission previously enacted Resolution R-79-04 allowing the Commission to finance the Connection Facilities Cost for potential Subsequent Customers on a case-by case basis when a potential Subsequent Customer requests such accommodation and

such accommodation would not be contrary to the best interests of the Commission as determined by the Board of Commissioners of the DuPage Water Commission; and

WHEREAS, Bartlett has requested, pursuant to Resolution R-79-04, that the Commission finance Bartlett's Connection Facilities Cost which will be owed under the Water Purchase and Sale Contract for the Bartlett Unit System; and

WHEREAS, the Board of Commissioners for the DuPage Water Commission hereby find that financing Bartlett's Connection Facilities Cost in this instance would not be contrary to the best interests of the Commission; and

WHEREAS, the Commission and Bartlett have each determined that it is in their respective best interests to enter into the Connection Facilities Loan Intergovernmental Agreement.

NOW, THEREFORE, BE IT ORDAINED, by the Board of Commissioners of the DuPage Water Commission as follows:

SECTION ONE: The foregoing recitals are hereby incorporated herein as findings of the Board of Commissioners of the DuPage Water Commission.

SECTION TWO: An Intergovernmental Agreement Concerning the Loan for Connection Facilities to Implement Water Service to the Village of Bartlett, in substantially the form attached hereto as Exhibit A, is hereby approved.

SECTION THREE: The Chairman of the DuPage Water Commission shall be and hereby is authorized to and directed to execute an Intergovernmental Agreement Concerning the Loan for Connection Facilities to Implement Water Service to the Village of Bartlett in substantially the form attached hereto as Exhibit A; provided, however, that said Intergovernmental

Agreement shall not be so executed on behalf of the DuPage Water Commission unless and until the Chairman shall have been presented with copies executed by the Village of Bartlett of the completed Intergovernmental Agreement Concerning the Loan for Connection Facilities to Implement Water Service and a Water Purchase and Sale Contract in substantially the form previously approved by the Commission.

SECTION FOUR: Upon execution by the Chairman, the Intergovernmental Agreement Concerning the Loan for Connection Facilities to Implement Water Service, and all other things provided for therein, shall be deemed accepted by the DuPage Water Commission without further act.

SECTION FIVE: This Ordinance shall be in full force and effect from and after its adoption by a majority affirmative vote of all the Commissioners including the affirmative vote of at least 1/3 of the Commissioners appointed by the County Board Chairman and 40 percent of the Commissioners appointed by the Mayors.

AYES:

NAYS:

ABSENT:

ADOPTED this 19th day of January, 2017

Chairman

ATTEST:

Clerk

EXHIBIT A

INTERGOVERNMENTAL AGREEMENT CONCERNING THE LOAN FOR
CONNECTION FACILITIES TO IMPLEMENT WATER SERVICE TO THE VILLAGE OF
BARTLETT

THIS AGREEMENT, made and entered into as of this _____ day of February, 2017 ("Effective Date"), by and between the DuPAGE WATER COMMISSION, a county water commission created and existing under the laws of the State of Illinois (the "Commission"), and the VILLAGE OF BARTLETT, a municipal corporation created and existing under the laws of the State of Illinois (the "Village"),

WITNESSETH:

WHEREAS, the Commission was formed and exists pursuant to the Water Commission Act of 1985, 70 ILCS 3720/0.01 *et seq.*, and Division 135 of Article 11 of the Illinois Municipal Code, 65 ILCS 5/11-135-1 *et seq.*, for the purpose of securing an adequate source and supply of water for its customers; and

WHEREAS, the Commission operates

a water system supplying a number of municipalities and other customers in DuPage County with water drawn from Lake Michigan; and

WHEREAS, the Village is seeking to obtain water for its residents from the Commission in the incorporated areas within the Village (the "Service Area"); and

WHEREAS, the construction of certain improvements to the Commission's Water System will enable the Village to provide water to the Service Area (the "Improvements"); and

WHEREAS, to carry out their duties and responsibilities, and desiring to create a method of providing an adequate supply of Lake Michigan water to the Service Area,

the Commission and the Village concurrent with this Agreement are entering into a Water Purchase and Sale Contract dated February _____, 2017 (the "Enabling Agreement"); and

WHEREAS, it is in the best interests of the Commission and the Village to coordinate and implement the supply of Lake Michigan water to the Service Area in accordance with the Enabling Agreement; and

WHEREAS, the Commission previously enacted Resolution R-79-04 allowing the Commission the ability to finance the Capital Facilities Cost for potential Subsequent Customers (customers other than Charter Customers) requesting such accommodation on a case-by case basis; and

WHEREAS, the Commission and the Village desire to set forth their understanding regarding such coordination and implementation in this Agreement; and

WHEREAS, the matters set forth in this Agreement will serve the public interest and assure that the residents the Service Area are provided safe water to the greatest extent possible; and

WHEREAS, pursuant to Section 10 of Article VII of the Illinois Constitution of 1970, the provisions of the Intergovernmental Cooperation Act, 5 ILCS 220/1 *et seq.*, and other applicable authority, the Commission and the Village are authorized to enter into this Agreement;

NOW, THEREFORE, in consideration of the foregoing and the mutual covenants and agreements hereinafter set forth, the Commission and the Village hereby agree as follows:

SECTION 1. INCORPORATION OF PREAMBLES AND DEFINITIONS FROM ENABLING AGREEMENT

The foregoing recitals are by this reference incorporated herein and made a part hereof as if fully set forth herein. Further, to the extent any capitalized terms in this Agreement are set forth as a defined term in the Enabling Agreement, the capitalized terms in this Agreement shall have the same meaning in this Agreement as the definition in the Enabling Agreement.

SECTION 2. CONSTRUCTION OF IMPROVEMENTS; EXTENSION OF SERVICE

A. Description of the Connection Facilities. For purposes of this Agreement, the Connection Facilities shall include the water mains, metering station and appurtenances necessary to be built by the Commission to provide water to the Village, including portions of the Waterworks System constructed by the Commission to initially connect the Bartlett Unit System to the Commission's existing Waterworks System as depicted in preliminary plans attached to the Enabling Agreement as Exhibits B-1 and B-2.

B. Design of the Connection Facilities. The Commission shall be the contracting party with the design engineer and shall administer the design contract for the benefit of both the Commission and the Village for the Connection Facilities. The Commission shall keep the Village advised as to the progress of the design work. The Commission and the Village shall confer upon issues regarding the details of such design work. The final design of the Connection Facilities shall be subject to the review of both the Commission and the Village and subject to the approval of the Village.

C. Land Acquisition. The Commission shall be responsible for the acquisition and divestment of lands, easements, and rights of way over lands and waters

necessary for the construction, installation, removal, relocation, replacement and extension or improvements of the Connection Facilities outside the corporate limits of the Village of Bartlett and all administrative, title, surveying, and legal fees, costs and expenses associated therewith, including, if necessary, exercising the power of eminent domain to procure any necessary easements, which expenses shall be added to the loan amount that Bartlett shall repay the Commission. The Commission shall keep the Village advised of all land acquisition costs and any necessary condemnation proceedings. All land acquired and costs associated therewith within the Village of Bartlett shall be the sole responsibility of the Village and shall not be paid out of the Loan Commitment.

D. Construction and Acceptance of the Connection Facilities. The Commission shall solicit bids for the construction of the Connection Facilities. The Commission's standard form of bidding and construction contract documents shall be used. The Commission shall solicit, award, and administer all contracts for the project in the best interest of both the Commission and the Village and shall consult with, and keep advised, Village officials regarding the progress of the work and any problems encountered or changes recommended. The Commission, after receiving the written consent of the Village to do so, once the winning contractor and the construction cost have been determined, shall enter into a construction contract(s) with the selected contractor(s), and shall administer such construction contract(s) in conformance with this Agreement. Any change order, as well as final acceptance and approval of the completed Connection Facilities, shall be subject to the final approval of the Commission.

E. Connection Facilities Cost. In accordance with Section 3 of this Agreement, the Commission shall loan the Village funds needed for the Connection Facilities Cost, except for the acquisition of real property and easements within the Village of Bartlett, up to the amount of the Commitment Amount as that term is hereinafter defined, and the Village agrees to reimburse the Commission for those costs.

F. Possible Shortfall. To the extent the Loan Commitment is determined to be insufficient to pay the Connection Facilities Cost, Section 7C of the Enabling Agreement shall apply.

SECTION 3. COMMISSION FINANCING

A. Loan. The Commission shall, after the execution and delivery of this Agreement, make available as a loan to the Village an amount of not to exceed \$21,000,000 (the "Commitment Amount") to pay the Connection Facilities Cost as defined in the Enabling Agreement. The actual moneys borrowed by the Village pursuant to the Commitment Amount will constitute the "Loan".

B. Loan Repayment.

1. The Village shall repay the principal balance of the Loan, plus accrued and unpaid interest at the Interest Rate set forth in Subsection 3.B.2 of this Agreement from the Interest Commencement Date through the Loan Payment Commencement Date (the "Capitalized Interest"), as those terms are hereinafter defined on the unpaid principal balance, and any Capitalized Interest, of the Loan from and after the Loan Payment Commencement Date, as that term is hereinafter defined, in 240

monthly installments, commencing on the 10th day of every month (the "Monthly Payment Date") commencing on the Loan Payment Commencement Date, and continuing in successive monthly installments on each Monthly Payment Date in each month thereafter, with the final payment of any unpaid interest and principal, if not sooner paid, on the 240th Monthly Payment Date. Each of the 240 monthly installments of principal on the Loan shall be determined as of the last day of the month preceding the Monthly Payment Date in any given year during the term of the Loan (a "Principal Determination Date") and shall be determined by dividing the unpaid principal balance, and any Capitalized Interest, of the Loan as of the applicable Principal Determination Date by the number of monthly installments of principal remaining to be paid during the term of the Loan. This monthly payment shall be considered the Connection Facilities Cost Payment as set forth in the Enabling Agreement. The accrued and unpaid interest shall be capitalized on a monthly basis until the Loan Payment Commencement Date.

2. Interest on the unpaid principal balance, and any Capitalized Interest, of the Loan shall accrue at a rate (the "Interest Rate") which is the lesser of: (i) the highest monthly average yield to maturity interest rate earned by the Commission (total all funds) as reported monthly on the Commission's Schedule of Investments for the immediately preceding fiscal year (May 1 – April 30) as

determined by the Commission (the "Earned Interest Rate") plus one per cent (1%); or (ii) four per cent (4%) per annum. Interest shall only accrue on moneys actually borrowed under Subsection 3D of this Agreement, and shall begin to accrue when the Commission makes its first draw on the loan for the Village (the "Interest Commencement Date"). The Interest Rate for each year that the Loan remains outstanding shall be calculated on the basis of a calendar year consisting of 360 days of twelve 30-day months and shall be adjusted on May 1st of each year, and shall be applied to the outstanding unpaid principal balance, and any Capitalized Interest, as determined on the most recent Principal Determination Date, shall be paid commencing on the Monthly Payment Date, and continuing on the Monthly Payment Date each month thereafter until the principal balance of the Loan and all interest thereon has been paid in full.

3. Payments of principal and interest, including Capitalized Interest, shall begin on the earlier of January 10, 2020 or the 10th day of the first month after the first delivery of potable, filtered water drawn from Lake Michigan to the Bartlett Unit System as that term is defined in the Enabling Agreement (the "Loan Payment Commencement Date").

C. Tender of Loan Payments. Payments of the principal of and interest shall be made in lawful money of the United States of America in federal or other immediately available funds.

D. Procedure for Borrowing. Upon the Commission's receipt of invoices incurred arising out of the Connection Facilities Cost as that term is defined in the Enabling Agreement, the Commission shall pay the actual costs incurred from the Connection Facilities Cost. The Commission payments for the Connection Facilities Cost shall be paid out of the Commitment Amount and will be immediately considered part of the Loan. The Commission may make payments from the Loan no more than once per month, on the 10th day of the month, provided that the Commission shall give the Village irrevocable notice (which notice must be received by the Village prior to 10:00 a.m., local time, 7 days prior to the requested borrowing date), specifying the amount to be paid and the payment date. It is anticipated that only a single borrowing shall be requested each month. Each borrowing pursuant to this Agreement shall be in an aggregate principal amount less than the Available Commitment. For purposes of this Section 3.D, the Available Commitment at a particular time is an amount equal to the difference between the Commitment Amount and the aggregate principal balance of the Loan then outstanding.

E. Optional Prepayments. Subject to the limitations of this Section 3.E, the Village may, no more frequently than once in any given year, prepay, in whole or in part, the Loan, without premium or penalty, upon at least one business day's irrevocable notice to the Commission, specifying the date and amount of prepayment. The amount of any such optional prepayment shall be in increments of \$50,000. If such notice is given, the Village shall make such prepayment and the payment amount specified in such notice shall be due and payable on the date specified therein. The proceeds of any such prepayment shall be applied by the Commission first, to the payment of accrued and unpaid interest, if any, on the Loan and second, to the payment of the

unpaid principal balance of the Loan. The Village shall not be entitled to, nor receive any credit for, interest on any such prepayment.

F. Application of Loan Proceeds. The proceeds of the Loan shall be devoted to and used with due diligence for the purpose of paying the Connection Facilities Cost identified in Exhibit A; provided, however, that where an unexpended balance remains in any one or more of the various cost components of the Connection Facilities Cost detailed in Exhibit A attached hereto, such balance may be transferred and expended, in whole or in part, to and for any other cost component of the Connection Facilities Cost detailed in Exhibit A attached hereto.

G. Covenants. The Covenants set forth in Subsections 9A, 9B, 9C and 9D of the Enabling Agreement are incorporated into this Agreement by reference.

SECTION 4. DEFAULTS AND REMEDIES

A. Commission Defaults. The occurrence of the following shall constitute a default by the Commission under this Agreement: The failure by the Commission to observe and/or perform any covenant, condition, and/or agreement on its part to be observed and/or performed under this Agreement, and the continuation of said failure for thirty (30) days after the Commission's receipt of written notice thereof from the Village. However, if said failure cannot be remedied by the Commission within said thirty (30) day period, and the Commission shall have diligently pursued the resolution of the failure during said thirty (30) days, the period shall be extended by such additional time as may be reasonably required by the Commission to cure or correct said failure. In no event shall the period be extended by more than ninety (90) days. In the event of a default by the Commission under this Agreement, the Village shall have the same

remedies as are provided for, and only the remedies provided for, in the Enabling Agreement for a default by the Commission.

B. Village Defaults. The occurrence of the following shall constitute a default by the Village under this Agreement: The failure by the Village to observe and/or perform any covenant, condition, and/or agreement on its part to be observed and/or performed under this Agreement, and the continuation of said failure for thirty (30) days after the Village's receipt of written notice thereof from the Commission. However, if said failure cannot be remedied by the Village within said thirty (30) day period, and the Village shall have diligently pursued the resolution of the failure during said thirty (30) days, the period shall be extended by such additional time as may be reasonably required by the Village to cure or correct said failure. In no event shall the period be extended by more than ninety (90) days.

In the event of a default by the Village, the Commission shall: (i) be paid its reasonable attorneys' fees and costs incurred in connection with that default, in addition to any attorneys' fees and costs incurred in enforcing the terms of this Agreement; (2) be entitled to the right to enforce a lien against all income derived from the Bartlett Unit System, other than that income necessary to pay any loans to the State of Illinois or its agencies for the construction of the Bartlett Unit System, until the Loan is paid back in full; and (3) shall have the same remedies as are provided for in the Enabling Agreement for a default by the Village.

C. Force Majeure. In case by reason of a force majeure event, either party to this Agreement shall be rendered unable wholly or in part to carry out its obligation under this Agreement, then if such party shall give notice and full particulars of such force majeure event in writing to the other party within a reasonable time after

occurrence of the event or cause relied on, the obligation of the party giving such notice, so far as it is affected by such force majeure event, shall be suspended during the continuance of the inability then claimed, but for no longer period, and any such party shall endeavor to remove or overcome such inability with all reasonable dispatch. The term "force majeure event" as employed in this Agreement shall mean acts of God, strikes, lockouts, or other industrial disturbances, acts of public enemy, orders of any kind of the Government of the United States, of the State of Illinois, or of any civil or military authority, insurrections, riots, epidemics, landslides, lightning, earthquakes, fires, hurricanes, storms, floods, washouts, droughts, arrests, restraints of government and people, civil disturbances, explosions, breakage or accidents to machinery, pipelines, canals, or tunnels, partial or entire failure of water supply, and inability on the part of the Commission or of the Village to deliver Lake Michigan water, or of the Village to receive Lake Michigan water, on account of any other causes not reasonably within the control of the party claiming such inability. The settlement of strikes and lockouts shall be entirely within the discretion of the party having the difficulty and the above requirement that any "force majeure event" shall be remedied with all reasonable dispatch shall not require the settlement of strikes and lockouts by acceding to the demands of the opposing party or parties when such settlement is unfavorable to it in the judgment of the party having the difficulty.

SECTION 5. LEGAL RELATIONSHIPS AND REQUIREMENTS

A. Supplemental Agreement. This Agreement shall be deemed to supplement the Enabling Agreement in connection with the supply of Lake Michigan water to the Service Area. If there is any other conflict or inconsistency between the terms of this Agreement and the terms of the Enabling Agreement, then the terms of

this Agreement shall control. The Village shall at all times comply with all terms and conditions of the Enabling Agreement except as otherwise provided in this Agreement.

B. Term of Agreement. This Agreement shall continue in full force and effect from the Effective Date until the Loan is paid in full by the Village.

C. Cooperation and Further Agreements. The Commission and the Village agree to meet and cooperate in good faith throughout the term of this Agreement to implement the letter and spirit of the provisions set forth in this Agreement.

D. Assignment. This Agreement may not be assigned by any party, in whole or in part, without the prior written consent of the other party.

E. Notices. All notices required or permitted to be given under this Agreement shall be in writing and shall be deemed received by the addressee thereof when delivered in person on a business day at the address set forth below or on the third business day after being deposited in any main or branch United States post office, for delivery at the address set forth below by properly addressed, postage prepaid, certified or registered mail, return receipt requested.

Notices and communications to the Commission shall be addressed to, and delivered at, the following address:

DuPage Water Commission
600 East Butterfield Road
Elmhurst, Illinois 60126-4642
Attention: General Manager

Notices and communications to the Village shall be addressed to, and delivered at, the following address:

Village of Bartlett
228 S. Main Street
Bartlett, Illinois 60103
Attention: Village Manager

By notice complying with the requirements of this Section 5.E, the Commission and the Village each shall have the right to change the address or addressee or both for all future notices to it, but no notice of a change of address shall be effective until actually received.

F. No Oral Agreements. No oral agreements exist by or between the Commission and the Village with respect to this Agreement, nor was the making and execution of this Agreement induced by any representation, statement, warranty, agreement, or action other than those expressed or explicitly referenced in this Agreement.

G. No Waiver. No course of dealing or failure of the Commission or the Village to enforce strictly any term, right, or condition of this Agreement shall be construed as a waiver of such term, right, or condition. No express waiver of any term, right, or condition of this Agreement shall operate as a waiver of any other term, right, or condition.

H. No Third Party Beneficiaries. This Agreement is entered into solely for the benefit of the contracting parties, and nothing in this Agreement is intended, either expressly or impliedly, to provide any right or benefit of any kind whatsoever to any person or entity who is not a party to this Agreement, or to acknowledge, establish, or impose any legal duty to any third party.

I. Governing Law and Venue. This Agreement shall be governed by and construed exclusively under the applicable laws, but not the conflict of laws rules, of the State of Illinois. Venue for any litigation arising out of this Agreement shall only be proper in the Eighteenth Judicial Circuit Court, DuPage County, Illinois.

J. Counterparts. This Agreement may be executed in several counterparts, each of which shall be deemed to be an original, and all of which shall constitute but one and the same instrument. Any such counterpart may be signed by one or more of the parties hereto so long as each of the parties hereto has signed one or more of such counterparts.

IN WITNESS WHEREOF, the Commission and the Village have caused this Agreement to be executed by their duly authorized officers, pursuant to proper authorization of their respective governing bodies, as of the date first stated above.

ATTEST:

DuPAGE WATER COMMISSION

By: _____

By: _____

Its: _____

Its: _____

ATTEST:

VILLAGE OF BARTLETT

By: _____

By: _____

Its: _____

Its: _____

EXHIBIT A

Connection Facilities Cost

DRAFT

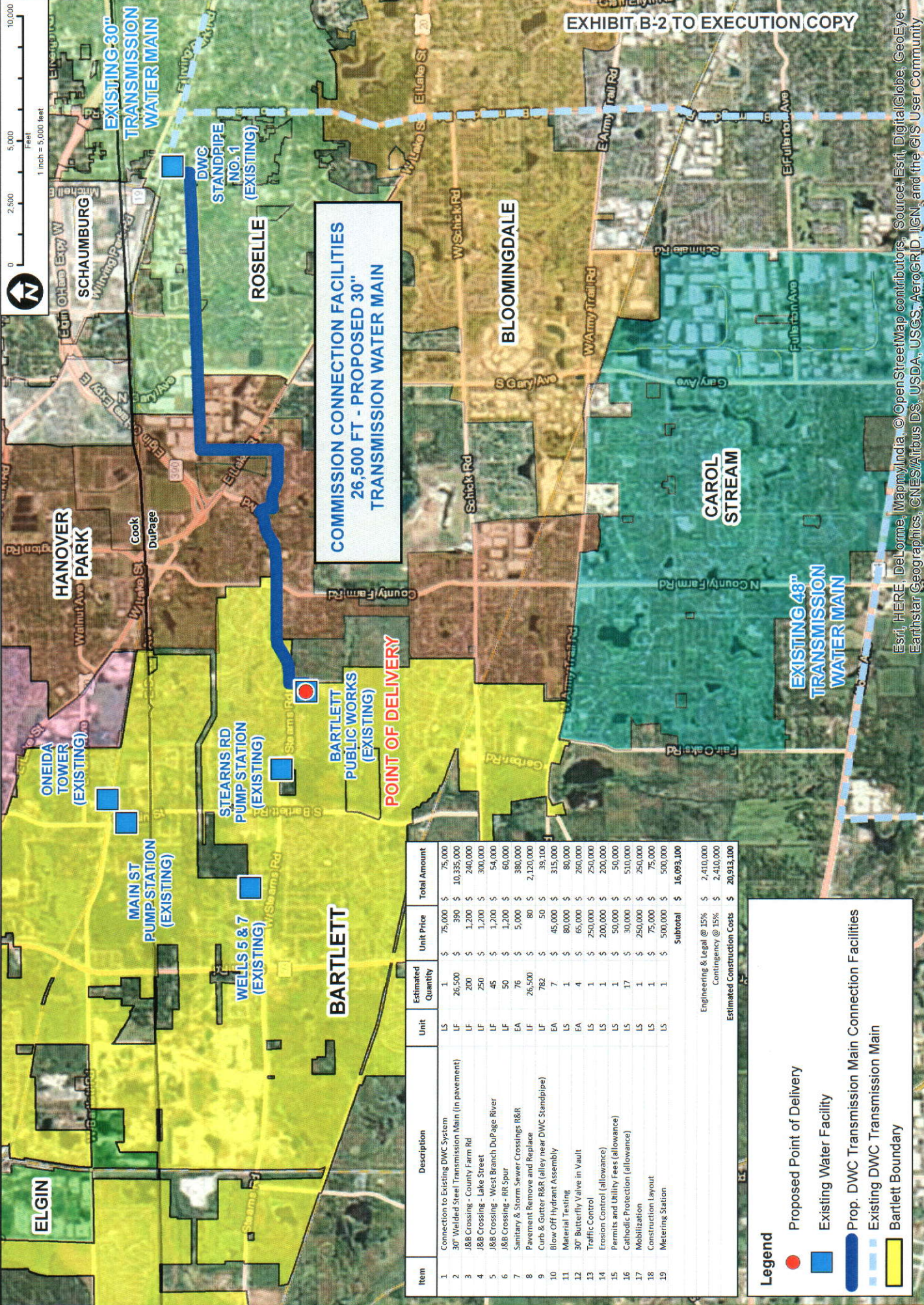

EXHIBIT B-2 TO EXECUTION COPY



**COMMISSION CONNECTION FACILITIES
26,500 FT - PROPOSED 30"
TRANSMISSION WATER MAIN**

POINT OF DELIVERY

Item	Description	Unit	Estimated Quantity	Unit Price	Total Amount
1	Connection to Existing DWC System	LS	1	\$ 75,000	\$ 75,000
2	30" Welded Steel Transmission Main (in pavement)	LF	26,500	\$ 390	\$ 10,335,000
3	J&B Crossing - County Farm Rd	LF	200	\$ 1,200	\$ 240,000
4	J&B Crossing - Lake Street	LF	250	\$ 1,200	\$ 300,000
5	J&B Crossing - West Branch DuPage River	LF	45	\$ 1,200	\$ 54,000
6	J&B Crossing - RT Spur	LF	50	\$ 1,200	\$ 60,000
7	Sanitary & Storm Sewer Crossings R&R	EA	76	\$ 5,000	\$ 380,000
8	Pavement Remove and Replace	LF	26,500	\$ 80	\$ 2,120,000
9	Curb & Gutter R&R (alley near DWC Standpipe)	LF	782	\$ 45	\$ 35,190
10	Blow Off Hydrant Assembly	EA	7	\$ 45,000	\$ 315,000
11	Material Testing	LS	1	\$ 80,000	\$ 80,000
12	30" Butterfly Valve in Vault	EA	4	\$ 65,000	\$ 260,000
13	Traffic Control	LS	1	\$ 250,000	\$ 250,000
14	Erosion Control (allowance)	LS	1	\$ 200,000	\$ 200,000
15	Permits and Utility Fees (allowance)	LS	1	\$ 50,000	\$ 50,000
16	Catholic Protection (allowance)	LS	17	\$ 30,000	\$ 510,000
17	Mobilization	LS	1	\$ 250,000	\$ 250,000
18	Construction Layout	LS	1	\$ 75,000	\$ 75,000
19	Metering Station	LS	1	\$ 500,000	\$ 500,000
Subtotal					\$ 16,093,100
Engineering & Legal @ 15%					\$ 2,410,000
Contingency @ 15%					\$ 2,410,000
Estimated Construction Costs					\$ 20,913,100

- Legend**
- Proposed Point of Delivery
 - Existing Water Facility
 - Prop. DWC Transmission Main Connection Facilities
 - - - Existing DWC Transmission Main
 - Bartlett Boundary

CHRISTOPHER B. BURKE ENGINEERING LTD
9575 West Higgins Road, Suite 600
Rosemont, Illinois 60018
(847) 823-0500

VILLAGE OF BARTLETT
228 S. Main Street
Bartlett, IL 60103

EXHIBIT B-2 TO EXECUTION COPY

**EXHIBIT
POINT OF DELIVERY**

NO.	REVISION	DATE	BY	APP'D.

PROJECT NO. 110404
DATE 01/12/17
DRAWING NO. EXH B-2

Esri, HERE, DeLorme, MapmyIndia, © OpenStreetMap contributors, Source: Esri, DigitalGlobe, GeoEye, Earthstar Geographics, CNES/Airbus DS, USDA, USGS, AeroGRID, IGN, and the GIS User Community

REQUEST FOR BOARD ACTION

AGENDA SECTION	Engineering and Construction Committee	ORIGINATING DEPARTMENT	Operations
ITEM	<p>Authorization for General Manager to execute a three (3) year Janitorial Services Contract with Eco Clean Maintenance Inc. estimated at \$75,182.40 for Periodic Janitorial Services at the DuPage Water Commission.</p> <p>Resolution No. R-1-17</p>	<p>APPROVAL</p> 	

Account Number: 01-60-629000

The Commission solicited sealed proposals for Janitorial Services at the DuPage Pumping Station by direct invitation, as well as by notice published in the *Daily Herald* on December 5 and 11, 2016 and by posting notice of the solicitation on the Commission's website starting December 5, 2016 and ending on January 4, 2017. Sealed proposals were received until 01:00 p.m., local time, January 04, 2017, at which time all proposals were publicly opened and read aloud.

Of the twenty companies that held copies of the Request for Proposals (RFP) document, three proposals were received (see tabulation below). Of the three proposals received, the proposal of Eco Clean Maintenance Inc. was found to be the lowest responsible bidder and most favorable to the interests of the Commission.

Company	Estimated Cost
Eco Clean Maintenance, Inc.	\$75,182.40
Multisystem Management Company	\$88,221.00
Perfect Cleaning Service Inc.	\$93,192.00

Staff recommends awarding the contract to the lowest responsible bidder Eco Clean Maintenance Inc. who is the Commission's current Janitorial Services provider. This contract included unit prices for periodic janitorial services at the DuPage Water Commission.

This request would authorize the General Manager to execute a three (3) year unit priced Janitorial Services contract with Eco Clean Maintenance Inc. estimated at \$75,182.40.

Resolution No. R-1-17 would award the contract to the lowest responsible bidder Eco Clean Maintenance, Inc.

The approved Management Budget for Fiscal Year 2016-2017 includes \$25,000.00 and tentative Management Budget for Fiscal Year 2017-2018 includes \$30,000.00 in account number 01-60-629000 for Janitorial Services at the DuPage Pumping Station. Board approval is required due to the three (3) year contract cost exceeding \$20,000.00.

MOTION: To authorize General Manager to execute a three (3) year Janitorial Services Contract with Eco Clean Maintenance Inc. estimated at \$75,182.40 for Periodic Janitorial Services at the DuPage Water Commission.

DuPAGE WATER COMMISSION
RESOLUTION NO. R-1-17
A RESOLUTION AWARDED A
CONTRACT FOR JANITORIAL SERVICES

WHEREAS, sealed proposals for the Janitorial Services Contract were received on January 4, 2017; and

WHEREAS, based upon staff's review of the proposals received, the Board of Commissioners of the DuPage Water Commission has determined that the proposal of Eco Clean Maintenance Inc. was the most favorable to the interests of the Commission;

NOW, THEREFORE, BE IT RESOLVED by the Board of Commissioners of the DuPage Water Commission as follows:

SECTION ONE: The foregoing recitals are incorporated herein as findings of the DuPage Water Commission.

SECTION TWO: The DuPage Water Commission hereby awards the Janitorial Services Contract to Eco Clean Maintenance Inc. for the unit prices set forth in its Contract/Proposal, estimated at \$75,182.40, conditioned upon the receipt of all contractually required documentation and such other additional information that may be requested by the General Manager of the Commission in accordance with the Request for Proposals document that is acceptable to the DuPage Water Commission.

SECTION THREE: This Resolution shall be in full force and effect from and after its adoption.

AYES:

NAYS:

ABSENT:

ADOPTED THIS ____ DAY OF _____, 2017.

Chairman

ATTEST:

Clerk

DATE: January 12, 2017

REQUEST FOR BOARD ACTION

AGENDA SECTION	Omnibus Vote Requiring Super-Majority or Special Majority Vote	ORIGINATING DEPARTMENT	Facilities Construction
ITEM	A Resolution Approving and Ratifying Certain Contract Change Orders for Masonry Rehabilitation and Window Replacement Work at the DuPage Pumping Station at the January 19, 2017, DuPage Water Commission Meeting Resolution No. R-2-17	APPROVAL	
Account Number: 01-60-771600			
Resolution No. R-2-17 would approve the following Change Orders:			
Change Order No. 1 for Masonry Rehabilitation and Window Replacement Work at the DuPage Pumping Station. Certain window units have failed over a several year span and had been identified in the 2014 Condition Assessment as part of the suggested building envelope rehabilitation but slated for replacement sometime in the future. Since the Commission received favorable pricing for the Masonry Rehabilitation and Window Replacement Work at the DuPage Pumping Station project, the scheduled additional window replacement work can be moved up for completion without impacting the current fiscal year's Capital Improvement Project budget.			
Approval of this Change Order would represent an increase in the Contract Price by \$34,470.00, increasing the Contract Price to \$320,915.00, but does not authorize or necessitate an increase in the Contract Price that is 50% or more of the original Contract Price nor, based upon the Contractor's sworn certification, authorize or necessitate an increase in the price of any subcontract under the Contract that is 50% or more of the original subcontract price.			
It is worth noting that during forensic investigation by the Contractor, the actual amount of masonry work needed and performed was much less than originally estimated and a future change order balancing the actual units will net a substantial decrease in contract price offsetting the cost of this change order.			
The Contractor's quotation is attached for reference.			
MOTION: To approve Resolution No. R-2-17.			

DuPAGE WATER COMMISSION

RESOLUTION NO. R-2-17

A RESOLUTION APPROVING AND RATIFYING
CERTAIN CONTRACT CHANGE ORDERS AT THE
JANUARY 19, 2017, DuPAGE WATER COMMISSION MEETING

BE IT RESOLVED by the Board of Commissioners of the DuPage Water Commission as follows:

SECTION ONE: The Change Orders set forth on Exhibit 1, attached hereto and by this reference incorporated herein and made a part hereof, shall be and hereby are approved and, if already issued, ratified because the Board of Commissioners of the DuPage Water Commission has determined that the circumstances said to necessitate the changes were not reasonably foreseeable at the time the contracts were signed, the Change Orders are germane to the original contracts as signed and/or the Change Orders are in the best interest of the DuPage Water Commission and authorized by law.

SECTION TWO: This Resolution shall constitute the written determination required by Section 33E-9 of Article 33E of the Criminal Code of 1961 and shall be in full force and effect from and after its adoption.

AYES:

NAYS:

ABSENT:

ADOPTED this _____ day of _____, 2017.

Chairman

ATTEST:

Clerk

Board\Resolutions\R-2-17.doc

Exhibit 1

Resolution No. R-2-17

1. Change Order No. 1 for Masonry Rehabilitation and Window Replacement Work at the DuPage Pumping Station in the net amount of \$34,470.00.

DUPAGE WATER COMMISSION
CHANGE ORDER

SHEET 1 OF 3

PROJECT NAME: DPPS Masonry Rehabilitation
And Window Replacements

CHANGE ORDER NO. 1

LOCATION: Elmhurst, Illinois

CONTRACT NO. N/A

CONTRACTOR: Mertes Contracting Corporation

DATE: January 19, 2016

I. A. DESCRIPTION OF CHANGES INVOLVED:

Add Lump Sum Price Item; C.O. #1, Add the Unit Price of \$34,470.00, and the number and type of units; 1 Ea., to the Schedule of Prices for Furnishing and Installing Replacement Windows for the Meter Shop Office Room 101, the Dispatch Office Room 102 (I/RF Supervisor), the Meeting Room (I/RF Tech Office) Room 104 and the Chlorine Building.

B. REASON FOR CHANGE:

Certain window units have failed over a several year span and had been identified in the 2014 Condition Assessment as part of the suggested building envelope rehabilitation but slated for replacement sometime in the future. Since the Commission received favorable pricing for the Masonry Rehabilitation and Window Replacement Work at the DuPage Pumping Station project, the scheduled additional window replacement work can be moved up for completion without impacting the current fiscal year's Capital Improvement Project budget.

REVISION IN CONTRACT PRICE:

Negotiated at \$34,470.00.

	<u> Unit Price Item </u>	<u> Unit </u>	<u> Number of Units </u>	<u> Price Per Unit </u>	<u> Extension </u>
C.O. #1	Add'l Replacement Windows	Ea.	1	\$34,470.00	\$34,470.00

II. CHANGE ORDER CONDITIONS:

1. The Completion Date established in the Contract, as signed or as modified by previous Change Orders, is hereby unchanged.
2. Any Work to be performed under this Change Order shall be provided, performed, and completed in full compliance with, and as required by or pursuant to, the Contract, including any Specifications and Contract Drawings for the Work to be performed under this Change Order and for Work of the same type as the Work to be performed under this Change Order, and as specified in the preceding "Description of Changes Involved."
3. Unless otherwise provided herein, all Work included in this Change Order shall be guaranteed and warranted as set forth in, and Contractor shall not be relieved from strict compliance with, the guaranty and warranty provisions of the Contract.
4. All Work included in this Change Order shall be covered under the Bonds and the insurance coverages specified in the Contract. If the Contract Price, including this Change Order, exceeds the Contract Price set forth in the Contract, as signed, by twenty percent (20%), Contractor shall submit to Owner satisfactory evidence of such increased coverage under the Bonds.

III. ADJUSTMENTS IN CONTRACT PRICE:

1.	Original Contract Price	\$	<u>286,445.00</u>
2.	Net (addition) (reduction) due to all previous Change Orders Nos. ____ to ____	\$	<u>0.00</u>
3.	Contract Price, not including this Change Order	\$	<u>286,445.00</u>
4.	(Addition) (Reduction) to Contract Price due to this Change Order	\$	<u>34,470.00</u>
5.	Contract Price including this Change Order	\$	<u>320,915.00</u>

RECOMMENDED FOR ACCEPTANCE:

ACCEPTED: By my authorized signature below, being first duly sworn on oath, I certify on behalf of Contractor that this Change Order does not authorize or necessitate an increase in the price of any subcontract under the Contract that is 50% or more of the original subcontract price.

CONTRACTOR: Mertes Contracting Corporation

By: _____ (_____)
Signature of Authorized Representative Date

DUPAGE WATER COMMISSION:

By: _____ (_____)
Signature of Authorized Date



MERTES CONTRACTING CORPORATION

2885 SOUTH 25TH AVENUE
BROADVIEW, ILLINOIS 60155-4691

Industrial and Commercial

PHONE 708/343-4800
FAX 708/343-5910

December 21, 2016

Chris Bostick
DuPage Water Commission
600 E. Butterfield Road
Elmhurst, IL 60126-4642

Re: Additional Window Replacement

Dear Chris Bostick:

Per your request, please review the following pricing for the above referenced project.

Mertes Contracting proposes to furnish all labor, material and equipment to complete the following:

Demo existing windows and install new thermal barrier single hung windows in dark bronze anodized finish along with dark aluminum mesh screen and automatic locking hardware limiting opening to 6". Glass will be the same as we installed on the south elevation of the Pump Building (1" Insulated 1/4" Bronze HS Tinted / Air / 5/16" Laminated (1/8" Solarban-60 / .060 / 1/8" Bronze HS)

We propose to complete this work as follows:

Bid #1 East Elevation of the Pump Building Three openings totaling twelve windows.	Total: \$24,835.00
Bid #2 North Elevation of the Chlorine Building Three openings totaling four windows.	Total: \$ 9,635.00

Note: No change in cost to change Bid #1 to three openings with three windows each.

We ask for your cooperation in providing us with access to the site, along with all necessary utilities, and a secure staging area for our equipment and material.
Mertes Contracting Corporation thanks you for the opportunity to present this proposal and hopes to be of service to you in the future. Should you have any questions please do not hesitate to call at any time.

Respectfully,

MERTES CONTRACTING CORPORATION



Mike Montgomery

"Over Fifty Years Experience"

All Types Building and Remodeling-Tuckpointing-Masonry Repair-Caulking-Concrete Restoration
Interest will be charged at the rate of 1 1/2 % per month on all accounts 30 days past due. • This proposal may be withdrawn if not accepted within 30 days.

DATE: January 12, 2017

REQUEST FOR BOARD ACTION

AGENDA SECTION Omnibus Vote Requiring Super-Majority or Special Majority Vote	ORIGINATING DEPARTMENT Facilities Construction/Safety Coordinator
ITEM A Resolution Approving and Ratifying Certain Change Orders for the Rehabilitation of Coating Systems and Fall Protection Systems for Tank Site No. 1 and No. 4 East (Contract SS-7/16) at the January 19, 2017, DuPage Water Commission Meeting Resolution No. R-3-17	APPROVAL   

Account Numbers: 01-60-770701

Resolution No. R-3-17 would approve the following Change Orders:

Change Order No. 1 to Contract Rehabilitation of Coating Systems and Fall Protection Systems for Tank Site No. 1 and No. 4 East (Contract SS-7/16).

1. During the execution of the work, it was determined that an unintentional omission was found in the specifications, not calling out the complete sandblasting and priming of the interiors of the standpipe pilasters as had been required on the previous rehabilitation contract. The Contractor submitted a proposal in the amount of \$20,000.00 to complete the additional work. The proposal was found to be acceptable to the Engineer and Staff accepted the proposal and the work was performed.
2. Included in the Contract Proposal are several indeterminate unit price items. The exact number of units was to be determined by the Resident Engineer and the final Contract Price determined accordingly. The modified units and Contract Price modification is as listed in the table below.
3. This Change Order would also grant Final Acceptance of the Work and Allow the General Manager to make Final Payment, including the release of all monies held in Retainage, conditioned upon receipt of all contractually required documentation.

Resolution No. R-3-17

AGENDA SECTION Omnibus Vote Requiring Super-Majority or Special Majority Vote	ORIGINATING DEPARTMENT Facilities Construction/Safety Coordinator
ITEM A Resolution Approving and Ratifying Certain Change Orders for the Rehabilitation of Coating Systems and Fall Protection Systems for Tank Site No. 1 and No. 4 East (Contract SS-7/16) at the January 19, 2017, DuPage Water Commission Meeting Resolution No. R-3-17	APPROVAL

<u>Item</u>	<u>Description</u>	<u>Unit</u>	<u>Contract Quantity</u>	<u>Price Per Unit</u>	<u>Final Quantity</u>	<u>Adjusted Quantity</u>	<u>Extension</u>
D.1	Repair Welding	Man-Hours	50	\$70.00	0	(50)	(\$3,500.00)
E.1	Pit Filling and Surfacing	Gallons	6	\$150.00	0	(6)	(\$900.00)
F.1	Interior Chipping and Grinding	Man-Hours	140	\$50.00	0	(140)	(\$7,000.00)
G.1	Balcony Drain Holes	Each	50	\$100.00	20	(30)	(\$3,000.00)
H.1	Grout Repair	Lineal Ft.	4	\$20.00	0	(4)	(\$80.00)
I.1	Crack Repair	Lineal Ft.	40	\$40.00	0	(40)	(\$1,600.00)
J.1	Spall Repair	Square Ft.	4	\$125.00	0	(4)	(\$500.00)
K.1	Miscellaneous Additional Work	Man-Hours	100	\$50.00	0	(100)	(\$5,000.00)
CO#1	Additional Sandblast/Painting	Lump Sum	0	\$10,000.00	2	2	\$20,000.00
Net Decrease							(\$1,580.00)

Approval of this Change Order would decrease the net Contract Price by \$1,580.00 making the Final Contract Price \$2,906,000.00.

Approval of this Change Order does not authorize or necessitate a decrease in the Contract Price that is 50% or more of the original Contract Price nor, based upon the Contractor's sworn certification, authorize or necessitate an increase in the price of any subcontract under the Contract that is 50% or more of the original subcontract price.

MOTION: To approve Resolution No. R-3-17.

DuPAGE WATER COMMISSION

RESOLUTION NO. R-3-17

A RESOLUTION APPROVING AND RATIFYING
CERTAIN CONTRACT CHANGE ORDERS AT THE
JANUARY 19, 2017, DuPAGE WATER COMMISSION MEETING

BE IT RESOLVED by the Board of Commissioners of the DuPage Water Commission as follows:

SECTION ONE: The Change Orders set forth on Exhibit 1, attached hereto and by this reference incorporated herein and made a part hereof, shall be and hereby are approved and, if already issued, ratified because the Board of Commissioners of the DuPage Water Commission has determined, based upon the representations of staff and the Contractors, that the circumstances said to necessitate the changes were not reasonably foreseeable at the time the contracts were signed, the Change Orders are germane to the original contracts as signed and/or the Change Orders are in the best interest of the DuPage Water Commission and authorized by law.

SECTION TWO: This Resolution shall constitute the written determination required by Section 33E-9 of Article 33E of the Criminal Code of 1961 and shall be in full force and effect from and after its adoption.

AYES:

NAYS:

ABSENT:

ADOPTED this _____ day of _____, 2017.

Chairman

ATTEST:

Clerk

Exhibit 1

Resolution No. R-3-17

1. Change Order No. 1 to Contract Rehabilitation of Coating Systems and Fall Protection Systems for Tank Site No. 1 and No. 4 East (Contract SS-7/16) for a \$1,580.00 net decrease in the Contract Price due to the balancing of indeterminate items and to Grant Final Acceptance of the Work.

DuPAGE WATER COMMISSION
CHANGE ORDER

SHEET 1 OF 3

PROJECT NAME: Rehabilitation of Coating Systems
and Fall Protection Systems for
Tank Site No. 1 and No. 4 East

CHANGE ORDER NO. 1

LOCATION: DuPage County, Illinois

CONTRACT NO. SS-7/16

CONTRACTOR: Era-Valdivia Contractors, Inc.

DATE: January 19, 2017

I. A. DESCRIPTION OF CHANGES INVOLVED:

1. Balancing of final indeterminate unit price items and grant Final Acceptance.

B. REASON FOR CHANGE:

1. Close out of indeterminate items.

C. REVISION IN CONTRACT PRICE:

1. Net Decrease of \$1,580.00 as detailed below.

<u>Item</u>	<u>Description</u>	<u>Unit</u>	<u>Contract Quantity</u>	<u>Price Per Unit</u>	<u>Final Quantity</u>	<u>Adjusted Quantity</u>	<u>Extension</u>
D.1	Repair Welding	Man-Hours	50	\$70.00	0	(50)	(\$3,500.00)
E.1	Pit Filling and Surfacing	Gallons	6	\$150.00	0	(6)	(\$900.00)
F.1	Interior Chipping and Grinding	Man-Hours	140	\$50.00	0	(140)	(\$7,000.00)
G.1	Balcony Drain Holes	Each	50	\$100.00	20	(30)	(\$3,000.00)
H.1	Grout Repair	Lineal Ft.	4	\$20.00	0	(4)	(\$80.00)
I.1	Crack Repair	Lineal Ft.	40	\$40.00	0	(40)	(\$1,600.00)
J.1	Spall Repair	Square Ft.	4	\$125.00	0	(4)	(\$500.00)
K.1	Miscellaneous Additional Work	Man-Hours	100	\$50.00	0	(100)	(\$5,000.00)
CO#1	Additional Sandblast/Painting	Lump Sum	0	\$10,000.00	2	2	\$20,000.00
Net Decrease							(\$1,580.00)

II. CHANGE ORDER CONDITIONS:

1. The Contract Period established in the Contract, as signed or as modified by previous Change Orders, maintains the Contract Completion Date of November 4, 2016.
2. Any Work to be performed under this Change Order shall be provided, performed, and completed in full compliance with, and as required by or pursuant to, the Contract, including any Specifications and Contract Drawings for the Work to be performed under this Change Order and for Work of the same type as the Work to be performed under this Change Order, and as specified in the preceding "Description of Changes Involved."
3. Unless otherwise provided herein, all Work included in this Change Order shall be guaranteed and warranted as set forth in, and Contractor shall not be relieved from strict compliance with, the guaranty and warranty provisions of the Contract.
4. All Work included in this Change Order shall be covered under the Bonds and the insurance coverages specified in the Contract. If the Contract Price, including this Change Order, exceeds the Contract Price set forth in the Contract, as signed, by twenty percent (20%), Contractor shall submit to Owner satisfactory evidence of such increased coverage under the Bonds if requested by Owner.

III. ADJUSTMENTS IN CONTRACT PRICE:

1.	Original Contract Price	\$	<u>2,907,580.00</u>
2.	Net (addition) (reduction) due to all previous Change Orders	\$	<u>0.00</u>
3.	Contract Price, not including this Change Order	\$	<u>2,907,580.00</u>
4.	(Addition) Reduction to Contract Price due to this Change Order	\$	<u>-1,580.00</u>
5.	Contract Price including this Change Order	\$	<u>2,906,000.00</u>

RECOMMENDED FOR ACCEPTANCE:

CONSULTING ENGINEERS: Dixon Engineering, Inc.

By: _____ (_____)
 Signature of Authorized Representative Date

ACCEPTED: By my authorized signature below, being first duly sworn on oath, I certify on behalf of Contractor that this Change Order does not authorize or necessitate an increase in the price of any subcontract under the Contract that is 50% or more of the original subcontract price.

CONTRACTOR: Era-Valdivia Contractors, Inc.

By: _____ (_____)
 Signature of Authorized Representative Date

DUPAGE WATER COMMISSION:

By: _____ (_____)
 Signature of Authorized Representative Date

DATE: January 6, 2017

REQUEST FOR BOARD ACTION

AGENDA SECTION	Engineering Committee	ORIGINATING DEPARTMENT	Instrumentation/Remote Facilities
ITEM	Telephone Services Over New Fiber Optic Cable	APPROVAL	<i>[Handwritten initials]</i> <i>[Handwritten initials]</i> <i>[Handwritten initials]</i>

Account Number: 01-60-651401

The Commission's current telephone services are through AT&T over a copper ISDN data circuit. This type of service is becoming obsolete with a sunset date of December, 2017. This technology is being replaced using a managed internet service over fiber optic cable. The Commission solicited quotations from ATT and two other third party telephone companies. Of the three quotations received, AT&T's proposal is the most favorable to the interests of the Commission. Staff is requesting the normal purchasing procedures of the Commission's By-Laws be suspended.

Telephone Service Provider	Internet Service	PRI with 15 Call Paths	Monthly Cost	3-Year Term Total
AT&T	\$599.00	\$153.75	\$752.75	\$27,099.00
Access One	\$689.90	\$185.00	\$874.90	\$31,496.40
SNet Communications	\$734.99	\$150.00	\$884.99	\$31,859.64

Note: These prices do not include taxes and other fees.

MOTION: To suspend the purchasing procedures of the Commission's By-Laws and to authorize General Manager to execute a 3-year term contract with AT&T for telephone services.



DuPage Water Commission

MEMORANDUM

TO: John Spatz, General Manager

FROM: Cheryl Peterson, Financial Administrator *CP* *JS*

DATE: January 10, 2017

SUBJECT: Accounts Payable Listings

Following is a summary of the Accounts Payable to be considered at the January 19, 2017 Commission meeting:

December 7, 2016 to January 10, 2017 A/P Report	\$8,268,216.34
Accrued and estimated payments required before February 2017 Commission meeting	<u>695,330.00</u>
Total	<u>\$8,963,546.34</u>

cc: Chairman and Commissioners



Payable Number	Description	Post Date	Payable Amount	Net Amount
Payable Account: 01-211000 - ACCOUNTS PAYABLE				
Vendor: 2083 130833	AIR COMFORT CORPORATION HVAC Services	12/31/2016	2,006.25	Payable Count: (1) 2,006.25
Vendor: 1306 INV0001479	AMWA Annual Dues: December 31, 2017	12/13/2016	5,000.00	Payable Count: (1) 5,000.00
Vendor: 1516 8640604	ARAMARK REFRESHMENTS Supplies	01/10/2017	52.68	Payable Count: (1) 52.68
Vendor: 1802 BT1045793	BAKER TILLY VIRCHOW KRAUSE, LLP PROFESSIONAL SERVICES: 11/28/16-12/22/16	12/31/2016	2,722.50	Payable Count: (1) 2,722.50
Vendor: 1692 27612	BRIDGEPOINT TECHNOLOGIES Hosting Services: January 2017	01/05/2017	45.00	Payable Count: (1) 45.00
Vendor: 1972 F-66195-0	CENTRO INC. Aquamatic valve rebuild kits	12/31/2016	370.14	Payable Count: (1) 370.14
Vendor: 2142 185303	CITY OF AURORA Monthly Microbial Analysis	12/22/2016	50.00	Payable Count: (1) 50.00
Vendor: 1134 INV0001511	CITY OF CHICAGO DEPARTMENT OF WATER LEX PUMP STATION LABOR: November 2016	12/31/2016	35,417.06	Payable Count: (1) 35,417.06
Vendor: 1135 INV0001510	CITY OF CHICAGO SUPERINTENDENT OF WATER COLLECTION WATER BILLING: December 2016	12/31/2016	8,033,912.88	Payable Count: (1) 8,033,912.88
Vendor: 1377 76304	CLC LUBRICANTS CO. Oil for pumps and motors	01/05/2017	1,201.20	Payable Count: (1) 1,201.20
Vendor: 1902 73491621	CONSTELLATION ENERGY SERVICES, INC. ELEC SVC: 11/29/16-12/30/16	12/31/2016	130,613.94	Payable Count: (1) 130,613.94
Vendor: 1797 INV0001517	DANIEL J. LOFTUS Serv. as Commissioner: July-December 2016	01/05/2017	300.00	Payable Count: (1) 300.00
Vendor: 1798 INV0001518	DAVID C. RUSSO Serv. as Commissioner: July-December 2016	01/05/2017	300.00	Payable Count: (1) 300.00
Vendor: 2076 INV0001523	DAVID NOVOTNY Serv. as Commissioner: July-December 2016	01/05/2017	300.00	Payable Count: (1) 300.00
Vendor: 1965 9019601	DISCOUNT TIRE Replace all 4 tires: M63637	12/22/2016	516.00	Payable Count: (1) 516.00
Vendor: 2003 5969	ECO CLEAN MAINTENANCE, INC. JANITORIAL SERVICE: December 2016	12/31/2016	1,858.45	Payable Count: (1) 1,858.45
Vendor: 2041 002-301602344	F.E. MORAN, INC. Prepare security fire systems	12/31/2016	520.00	Payable Count: (1) 520.00
Vendor: 1420 ILELM20691	FASTENAL COMPANY Pipeline Gloves	12/31/2016	709.21	Payable Count: (1) 709.21
Vendor: 1570 2470397 2470569	FIVE STAR SAFETY EQUIPMENT, INC. Pipeline Supplies Pipeline Supplies	12/31/2016 01/10/2017	516.75 450.00	Payable Count: (2) 966.75 516.75 450.00
Vendor: 1843	FLEETMATICS			Payable Count: (1) 313.74

Board Open Payable Report

As Of 01/10/2017

Payable Number	Description	Post Date	Payable Amount		Net Amount
<u>IN1546086</u>	VEHICLE TRACKING SUBSCRIPTION	12/31/2016	313.74		313.74
Vendor: 2037 <u>1602</u>	GREEN WINDOW CLEANING SERVICES MONTHLY CLEANING: November 2016	12/31/2016	453.50	Payable Count: (1)	453.50
Vendor: 1068 <u>10236905</u> <u>10238318</u>	HACH COMPANY Chemicals for Analyzers Monthly Chemicals	12/22/2016 12/31/2016	213.21 309.89	Payable Count: (2)	523.10
Vendor: 1197 <u>G500808</u>	HD SUPPLY WATERWORKS, LTD. Sensus Omni Chamber Gaskets	12/31/2016	122.23	Payable Count: (1)	122.23
Vendor: 1243 <u>INV0001515</u>	IGFOA 2017 Membership renewal: Peterson	01/05/2017	375.00	Payable Count: (1)	375.00
Vendor: 1063 <u>200026131</u> <u>200026283</u>	ILLINOIS SECTION AWWA Watercon 2017: Weed & Spatz Watercon 2017: Schori	12/22/2016 12/31/2016	500.00 250.00	Payable Count: (2)	750.00
Vendor: 1904 <u>05015000</u>	IT SAVVY LLC IT Network Support	01/05/2017	6,701.00	Payable Count: (1)	6,701.00
Vendor: 2077 <u>INV0001522</u>	JOSEPH FENNELL Serv. as Commissioner: July-December 2016	01/05/2017	300.00	Payable Count: (1)	300.00
Vendor: 2098 <u>5719</u> <u>5722</u>	KRAMER DATAPOWER, INC. Battery system maintenance Services for switchgear and generator batteries	12/22/2016 12/31/2016	770.00 1,152.00	Payable Count: (2)	1,922.00
Vendor: 1795 <u>INV0001516</u>	LAURA CRAWFORD Serv. as Commissioner: July-December 2016	01/05/2017	300.00	Payable Count: (1)	300.00
Vendor: 1195 <u>1/891610</u>	LESMAN INSTRUMENT COMPANY AC Isolator Module for data logger	12/31/2016	317.96	Payable Count: (1)	317.96
Vendor: 1823 <u>501440449196</u>	MARSH USA INC. Casualty Consulting 16/17	12/31/2016	31,421.75	Payable Count: (1)	31,421.75
Vendor: 1799 <u>INV0001519</u>	MICHAEL R. SCHECK Serv. as Commissioner: July-December 2016	01/05/2017	300.00	Payable Count: (1)	300.00
Vendor: 1395 <u>886851336001</u>	OFFICE DEPOT Office Supplies	12/22/2016	30.58	Payable Count: (1)	30.58
Vendor: 1178 <u>T4457056</u>	PADDOCK PUBLICATIONS, INC. Public Notice	12/31/2016	78.20	Payable Count: (1)	78.20
Vendor: 1113 <u>PM600260904</u>	PATTEN INDUSTRIES, INC. Service for diesel generator	12/31/2016	178.55	Payable Count: (1)	178.55
Vendor: 1321 <u>85469</u>	PERSPECTIVES, LTD. EMPLOYEE ASSISTANCE SVC: 1st QUARTER	01/05/2017	273.00	Payable Count: (1)	273.00
Vendor: 1059 <u>000000012-S045</u>	RED WING SHOE STORE Safety Shoes: Arredondo	01/10/2017	267.74	Payable Count: (1)	267.74
Vendor: 1811 <u>INV0001521</u>	RICHARD R. FURSTENAU Serv. as Commissioner: July-December 2016	01/05/2017	300.00	Payable Count: (1)	300.00
Vendor: 2075 <u>INV0001520</u>	ROBERT GANS Serv. as Commissioner: July-December 2016	01/05/2017	300.00	Payable Count: (1)	300.00
Vendor: 1044 <u>92240</u> <u>92241</u>	ROYAL GRAPHICS PRINTERS Office Supplies Office Supplies	12/13/2016 12/13/2016	227.51 42.00	Payable Count: (2)	269.51
Vendor: 2156	Russo Power Equipment			Payable Count: (1)	1,699.96

Board Open Payable Report

As Of 01/10/2017

Payable Number	Description	Post Date	Payable Amount		Net Amount
<u>3694756</u>	Replacment Concrete Saws	01/10/2017	1,699.96		1,699.96
Vendor: <u>2101</u>	SITEONE LANDSCAPE SUPPLY, LLC			Payable Count: (1)	833.35
<u>78739121</u>	Salt and CaCl	12/22/2016	833.35		833.35
Vendor: <u>1043</u>	SOOPER LUBE			Payable Count: (4)	136.09
<u>279815</u>	Vehicle Maint: M149226	12/22/2016	45.20		45.20
<u>279821</u>	Vehicle Maint: M184222	12/22/2016	36.95		36.95
<u>280063</u>	Vehicle Maint: M66159	12/22/2016	36.95		36.95
<u>280919</u>	Vehicle Maintenance: M78556	01/10/2017	16.99		16.99
Vendor: <u>1223</u>	SUBURBAN LABORATORIES, INC.			Payable Count: (2)	689.00
<u>140569</u>	BAC-T Sample Analysis	12/22/2016	190.00		190.00
<u>141300</u>	BAC-T Sample Analysis	12/31/2016	499.00		499.00
Vendor: <u>1123</u>	THOMPSON ELEVATOR INSPECTION SERVICE, INC.			Payable Count: (1)	55.00
<u>16-4041</u>	Semi annual elevator inspection	12/31/2016	55.00		55.00
Vendor: <u>1125</u>	TOTAL FIRE & SAFETY, INC.			Payable Count: (1)	309.60
<u>101790</u>	Annual fire extinguisher inspection	12/31/2016	309.60		309.60
Vendor: <u>2029</u>	TREE TOWNS IMAGING & COLOR GRAPHICS			Payable Count: (1)	43.42
<u>0000242967</u>	Reduced plan sets of Meter Stations	12/13/2016	43.42		43.42
Vendor: <u>2096</u>	William A. Fates			Payable Count: (1)	1,250.00
<u>INV0001524</u>	Services as Treasurer: January 2017	01/05/2017	1,250.00		1,250.00
Vendor: <u>2127</u>	Windy City Electric Co.			Payable Count: (1)	840.00
<u>18454</u>	QRE 7/15 Bond and Insurance	12/31/2016	840.00		840.00
Payable Account 01-211000				Payable Count: (58)	Total: 8,268,216.34

Payable Account Summary

Account	Count	Amount
01-211000 - ACCOUNTS PAYABLE	58	8,268,216.34
Report Total:	58	8,268,216.34

Payable Fund Summary

Fund	Count	Amount
01 - WATER FUND	58	8,268,216.34
Report Total:	58	8,268,216.34

DUPAGE WATER COMMISSION
ITEMS TO BE PAID BY 2-16-17
Board Meeting Date: January 19, 2017

Estimate Amount	Description	Check Number	Payment Date	Payment Amount
52,000.00	Blue Cross Blue Shield - Health Insurance			
6,000.00	Euclid Managers - Dental Insurance			
10,000.00	Illinois Public Risk Fund - Workers Comp.			
200.00	Envision Health Care - Administration Fees			
300.00	Healthiest You			
20,000.00	ComEd - Utility Charges			
300,000.00	Constellation (Exelon Energy) - Utility Charges			
180,000.00	City of Chicago - Lexington. Electric			
2,000.00	City of Chicago - Repairs & Maintenance			
2,000.00	City of Naperville -Meter Station Electric Bills			
15,000.00	Nicor - Gas			
250.00	Comcast - Internet Service			
2,000.00	AT & T - Telephone Charges			
2,600.00	AT & T - Scada Backhaul Network			
1,000.00	Fed - Ex - Postage/Delivery			
5,000.00	Procurement Card Charges			
200.00	Anderson - Pest Control			
400.00	Republic Services - Disposal Services			
200.00	Elecsys - Cell Data Services			
1,500.00	Konica Minolta - Copy and Lease Charges			
525.00	Pitney Bowes - Postage			
8,000.00	Grainger - Supplies for Operations			
2,500.00	Verizon - Wireless Service			
1,250.00	William Fates - Treasurer			
5,200.00	Baker Tilly			
6,700.00	Gorski & Good			
1,500.00	Rory Group			
6,000.00	John J. Millner & Assoc			
7,000.00	IT Savvy - Network Support			
255.00	City of Elmhurst - Wireless Radio			
200.00	Edward Coughlin/Ken Lafin - Security			
250.00	Storino Ramello & Durkin			
500.00	Local 399 Training courses			
20,000.00	Irth Solutions			
1,000.00	AMS Environmental - Chemical Disposal			
350.00	Cintas - Safety Supplies			
50.00	City of Aurora - Lab Testing			
1,800.00	Comprehensive Communications - Routers			

DUPAGE WATER COMMISSION
ITEMS TO BE PAID BY 2-16-17
Board Meeting Date: January 19, 2017

200.00 Crown Battery - Generator Battery
6,500.00 Door Systems - Overhead door repairs
200.00 Elmhurst Plaza Standard - Vehicle Repairs
300.00 Fastenal - Pipeline Gloves
1,500.00 Gas Depot - Gasoline
300.00 Glenbard - Replacement Transformer
500.00 Green Windows - Window Cleaning
400.00 Hach - Monthly Chemicals
50.00 Hi-Line - Meter Station Supplies
600.00 Hughes Lock - Door Repairs
1,300.00 Illinois Fire Extinguisher - Repairs
100.00 ISAWWA - AWWA Seminar for Weed
3,000.00 Kramer Datapower - Services for Switchgear
500.00 National Lift Truck - Manlift Inspections
150.00 Networkfleet - Monthly Diagnostics
400.00 Office Depot - Office Supplies
7,000.00 Peterson Product - Plug for Pipe Repair
2,000.00 Park Place - Server Maintenance Agreement
500.00 Red Wing - Safety Shoes
800.00 Specialty Mat - Cleaning Services
2,500.00 Staking University - Training Class
300.00 Staples - Office Supplies
100.00 Triton College - Training
400.00 Watercon - Weed and Spatz
2,000.00 Whiting Services - Repairs to Crane and Hoists

695,330.00



DuPage Water Commission

MEMORANDUM

TO: Chairman Zay and Commissioners

FROM: John F. Spatz 
General Manager

DATE: January 12, 2017

SUBJECT: December 2016 Invoice

I reviewed the Gorski & Good, LLP (Schirott, Luetkehans & Garner) December 2016 invoice for services rendered during the period December 1, 2016 – December 31, 2016 and recommend it for approval. This invoice should be placed on the January 19, 2017 Commission meeting accounts payable.

December 2016
Gorski & Good /
(Schirott, Luetkehans & Garner)

CATEGORY	<u>FEES</u>	<u>HOURS BILLED</u>	<u>AVERAGE HOURLY RATE</u>	<u>ATTORNEYS & PARALEGALS EMPLOYED</u>	<u>MAJOR ACTIVITIES</u>
General	\$6,540.00	32.7	\$200.00	Good (.5 @ \$200/hr.) Luetkehans (32.40 @\$200/hr.)	Discussion of agreements and Board packet material
Misc:	<u>\$22.95</u>				
	<u>\$6,562.95</u>	<u>32.7</u>	<u>\$200.00</u>		