



DuPage Water Commission

600 E. Butterfield Road, Elmhurst, IL 60126-4642
(630) 834-0100 Fax: (630) 834-0120

AGENDA

DUPAGE WATER COMMISSION

THURSDAY, AUGUST 15, 2019
6:30 P.M.

600 EAST BUTTERFIELD ROAD
ELMHURST, IL 60126

I. Call to Order and Pledge of Allegiance

II. Roll Call

(Majority of the Commissioners then in Office—minimum 7)

III. Oath of Office

Kathleen Rush, County Representative District 3

IV. Public Comments (limited to 3 minutes per person)

V. Approval of Minutes

(Concurrence of a Majority of those Commissioners Present, provided there is a quorum—minimum 4)

RECOMMENDED MOTION: To approve the Minutes of the June 20, 2019 Regular Meeting of the DuPage Water Commission (Voice Vote).

VI. Treasurer's Reports – June and July 2019

(Concurrence of a Majority of those Commissioners Present, provided there is a quorum—minimum 4)

RECOMMENDED MOTION: To accept the June and July 2019 Treasurer's Reports (Voice Vote).

VII. Committee Reports

A. Finance Committee

1. Report of 8/15//19 Finance Committee

2. The 2019 Annual Audit Report

(Concurrence of a Majority of those Commissioners Present, provided there is a quorum- minimum 4)

All visitors must present a valid driver's license or other government-issued photo identification, sign in at the reception area and wear a visitor badge while at the DuPage Pumping Station.

RECOMMENDED MOTION: To accept the draft audit report for the fiscal year ending April 30, 2019, to direct the auditors to print the final report, and to direct staff to distribute the FY2019 audit report to the Commission's customers and other interested parties (Roll Call)

3. Actions on Other Items Listed on 8/15/19 Finance Committee Agenda

B. Administration Committee

1. Report of 8/15/19 Administration Committee
2. Resolution No. R-27-19: A Resolution Authorizing and Ratifying the Disposal of Certain Personal Property Owned by the DuPage Water Commission (**no cost**)

(Concurrence of a Majority of the Appointed Commissioners - 7)

RECOMMENDED MOTION: To adopt item number 2 under the Administration Report section of the Agenda in a single group pursuant to the Omnibus Vote Procedures (Roll Call).

3. Actions on Other Items Listed on 8/15/19 Administration Committee Agenda

C. Engineering & Construction Committee

1. Report of 8/15/19 Engineering & Construction Committee
2. Ordinance No. O-5-19: An Ordinance Determining the Prevailing Rate of Wages in DuPage County and Cook County (**no cost**)

(Concurrence of a Majority of the Appointed Commissioners - 7)

3. Resolution No. R-22-19: A Resolution Directing Advertisement for Bids on a contract for 36-month Maintenance, Parts and Repair service for Large Electric Motors (**no cost**)

(Concurrence of a Majority of the Appointed Commissioners - 7)

4. Resolution No. R-23-19: A Resolution approving a First Amendment to Task Order No. 1 under a Master Contract with **Greeley and Hansen (for an additional cost not-to-exceed \$8,000.00)**

(Concurrence of a Majority of the Appointed Commissioners - 7)

5. Resolution No. R-24-19: A Resolution Approving and Ratifying Certain Work Authorization Orders Under Quick Response Contract QR-11/17 at the August 15, 2019, DuPage Water Commission Meeting (**John Neri Construction Co., Inc., in the amount of \$3,100.00**)

(Affirmative Majority of the Appointed Commissioners, containing the votes of at least 1/3 of the County Appointed Commissioners and 40% of the Municipal Appointed Commissioners—3 County + 3 Muni+1=7)

6. Resolution No. R-25-19: A Resolution Approving and Ratifying Certain Work Authorization Orders Under Quick Response Electrical Contract QRE-8/17 at the August 15, 2019, DuPage Water Commission Meeting (**Volt Electric, Inc., in an estimated cost of \$11,221.00**)

(Concurrence of a Majority of the Appointed Commissioners - 7)

7. Resolution No. R-26-19: A Resolution to Suspend Purchasing Procedures and Authorize the General Manager to Purchase Spare Medium Voltage Breakers and Power Transformer (**Industrial Electric Manufacturing at an estimated cost of \$68,000.00**)

(TO SUSPEND PURCHASING PROCEDURES: 2/3 Majority of those Commissioners Present, provided there is a quorum)

(Affirmative Majority of the Appointed Commissioners, containing the votes of at least 1/3 of the County Appointed Commissioners and 40% of the Municipal Appointed Commissioners—3 County + 3 Muni+1=7)

8. Resolution No. R-28-19: A Resolution Approving and Ratifying Certain Work Authorization Orders Under Quick Response Electrical Contract QRE-8/17 at the August 15, 2019, DuPage Water Commission Meeting (**WAO #12 to Volt Electric, Inc. at an estimated cost of \$6,240.00 and WAO #13 to McWilliams Electric, Inc., at an estimated cost of \$9,540.00**)

(Concurrence of a Majority of the Appointed Commissioners - 7)

9. Resolution No. R-29-19: A Resolution Directing Advertisement for Bids on a Contract for the Fabrication of Valve Stem Risers (**no cost**)

(Concurrence of a Majority of the Appointed Commissioners - 7)

RECOMMENDED MOTION: To adopt item numbers 2 through 9 under the Engineering & Construction Report section of the Agenda in a single group pursuant to the Omnibus Vote Procedures (Roll Call).

10. Actions on Other Items Listed on 8/15/19 Engineering & Construction Committee Agenda

VIII. Accounts Payable – June and July 2019

(Affirmative Majority of the Appointed Commissioners, containing the votes of at least 1/3 of the County Appointed Commissioners and 40% of the Municipal Appointed Commissioners—3 County + 3 Muni+1=7)

RECOMMENDED MOTION: To approve the Accounts Payable in the amount of \$9,001,104.08 (June 2019, disbursements made with concurrence of Commission's Chairman) and \$11,158,828.80 (July 2019) subject to submission of all contractually required documentation, for invoices that have been received (Roll Call).

RECOMMENDED MOTION: To approve the Accounts Payable in the amount of \$1,147,825.00 (June 2019, disbursements made with concurrence of Commission's Chairman) and \$940,525.00 (July 2019) subject to submission of all contractually required documentation, for invoices that have not yet been received but have been estimated (Roll Call).

- IX. Chairman's Report
- X. Omnibus Vote Requiring Majority Vote
- XI. Omnibus Vote Requiring Super-Majority or Special Majority Vote
- XII. Old Business
- XIII. New Business
- XIV. Executive Session

(Concurrence of a Majority of those Commissioners Present, provided there is a quorum—minimum 4)

RECOMMENDED MOTION: To go into Executive Session to discuss security procedures pursuant to 5 ILCS 120/2(c)(8), to discuss matters related to personnel pursuant to 5 ILCS 120/2(c)(1) and (2), to discuss acquisition of real estate pursuant to 5 ILCS 120/2(c)(5), to discuss pending, probable, or imminent litigation pursuant to 5 ILCS 120/2(c)(11), and/or to discuss minutes of closed meetings pursuant to 5 ILCS 120/2(c)(21) (Roll Call).

RECOMMENDED MOTION: To come out of Executive Session (Voice Vote).

- XV. Adjournment

(Concurrence of a Majority of those Commissioners Present, provided there is a quorum—minimum 4)

**MINUTES OF A MEETING OF THE
DUPAGE WATER COMMISSION
HELD ON THURSDAY, JUNE 20, 2019
600 E. BUTTERFIELD ROAD
ELMHURST, ILLINOIS**

The meeting was called to order by Chairman Zay at 6:33 P.M.

Commissioners in attendance: J. Broda, J. Fennell, R. Gans, J. Healy, D. Novotny, R. Obarski, J. Pruyne, F. Saverino, and J. Zay

Commissioners Absent: D. Bouckaert, D. Russo, and P. Sues

Also in attendance: Treasurer W. Fates, J. Spatz, C. Peterson, A. Stark, T. McGhee, F. Frelka, J. Schori, D. Cuvalo, C. Bostick and P. Luetkehans of Schirott, Luetkehans & Garner, LLC.

Chairman Zay began by asking for a moment of silence in remembrance of Commission employee Michael Ladegaard who passed away due to illness noting his friendly personality and dedication would be greatly missed.

PUBLIC COMMENT

None

APPROVAL OF MINUTES

Commissioner Healy moved to approve the Minutes of the April 18, 2019 Regular Meeting of the DuPage Water Commission. Seconded by Commissioner Broda and unanimously approved by a Voice Vote.

All voted aye. Motion carried.

TREASURER'S REPORT

Treasurer Fates presented the April and May 2019 Treasurer's Reports each consisting of 12 pages, noting that pages 1 and 2 contained a brief summary of the reports.

April 2019

Treasurer Fates pointed out the \$171.2 million of cash and investments on page 4, which reflected a decrease of about \$1.1 million from the previous month. Treasurer Fates also pointed out the schedule of investments on pages 5 through 10 totaling \$153.4 million and the market yield on the total portfolio showed 2.17% which has slightly increased from the prior month. On page 11, the statement of cash flows showed a decrease in cash and investments by about \$3.4 million and operating activities generated \$11.0 million, and roughly \$113,000 of sales tax was received. On page 12, the monthly cash/operating report showed that the Commission had met or exceeded all of its reserve requirements.

Minutes of the 6/20/2019 Commission Meeting

May 2019

Treasurer Fates pointed out the \$172.1 million of cash and investments on page 4, which reflected an increase of about \$0.9 million from the previous month. Treasurer Fates also pointed out the schedule of investments on pages 5 through 10 totaling \$153.7 million and the market yield on the total portfolio showed 2.17% which was unchanged from the prior month. On page 11, the statement of cash flows showed an increase in cash and investments by about \$0.9 million and operating activities generated \$0.7 million. On page 12, the monthly cash/operating report showed that the Commission had met or exceeded all of its reserve requirements.

Commissioner Broda moved to accept the April and May 2019 Treasurer's Reports.
Seconded by Commissioner Obarski and unanimously approved by a Voice Vote.

All voted aye. Motion carried.

COMMITTEE REPORTS

Finance Committee – Reported by Commissioner Pruyn

Commissioner Pruyn reported that the Finance Committee had reviewed all items on the Finance Committee Agenda with no action items for consideration.

Administration Committee

Meeting Cancelled

Engineering & Construction Committee – Reported by Commissioner Fennell

Commissioner Fennell reported that the Engineering & Construction Committee reviewed and recommended for approval all action items listed on the Engineering & Construction Committee Agenda and welcomed any questions. Hearing none, Commissioner Fennell moved to adopt item numbers 2 through 5 under the Engineering & Construction Report section of the Agenda in a single group pursuant to the Omnibus Vote Procedures. Seconded by Commissioner Saverino and unanimously approved by a Roll Call Vote.

Ayes: J. Broda, J. Fennell, R. Gans, J. Healy, D. Novotny, R. Obarski, J. Pruyn, F. Saverino, and J. Zay

Nays: None

Absent: D. Bouckaert, D. Russo and P. Suess

Item 2: Resolution No. R-18-19: A Resolution Approving and Ratifying Certain Task Orders Under a master Contract with AECOM Technical Services, Inc. at the June 20, 2019 DuPage Water Commission Meeting (AECOM Technical Services at an increase cost from \$15,000.00 to \$35,000.00)

Minutes of the 6/20/2019 Commission Meeting

- Item 3: Resolution No. R-19-19: A Resolution Approving and Ratifying Certain Task Orders Under a Master Contract with Carollo Engineering at the June 20, 2019, DuPage Water Commission Meeting (Carollo Engineering, Inc. in the amount of \$883,434.00)
- Item 4: Resolution No. R- 20-19: A Resolution Approving and Ratifying Certain Contract Change Orders at the June 20, 2019 DuPage Water Commission Meeting (Contract MS-21/19 - JJ Henderson and Son, Inc. net increase of \$36,457.00)
- Item 5: Resolution No. R-21-19: A Resolution Directing Advertisement for Bids on a Contract for the DPPS Sodium Hypochlorite Facility Improvements (Contract PSD-8/19 – no cost)

ACCOUNTS PAYABLE

Commissioner Pruyn moved to approve the Accounts Payable in the amount of \$8,229,110.46 (April 2019, disbursements made with concurrence of Commission's Chairman) and \$8,511,008.89 (May 2019) subject to submission of all contractually required documentation, for invoices that have been received and to approve the Accounts Payable in the amount of \$1,401,575.00 (April 2019, disbursements made with concurrence of Commission's Chairman) and \$1,163,225.00 (May 2019) subject to submission of all contractually required documentation, for invoices that have not yet been received but have been estimated. Seconded by Commissioner Broda and unanimously approved by a Roll Call Vote.

Ayes: J. Broda, J. Fennell, R. Gans, J. Healy, D. Novotny, R. Obarski, J. Pruyn, F. Saverino, and J. Zay

Nays: None

Absent: D. Bouckaert, D. Russo and P. Sues

CHAIRMAN'S REPORT

Chairman Zay began by thanking staff for their work on completing the Village of Bartlett project noting that the ribbon cutting ceremony went very well and thanked those that were able to attend.

Chairman Zay stated that staff met with representatives from the Village of Bolingbrook, as well as the Village of Shorewood both of which are interested in the possibility of the Commission supplying water to their communities. General Manager Spatz added that he had reviewed a cost analysis with the Village of Shorewood and that the Village seemed interested in discussing further.

OMNIBUS VOTE REQUIRING MAJORITY VOTE

None

OMNIBUS VOTE REQUIRING SUPER-MAJORITY OR SPECIAL MAJORITY VOTE

None

OLD BUSINESS

General Manager Spatz began by noting that the Commission had received a Citation and Notification of Penalty from the Illinois Department of Labor regarding the fatal accident involving employee Rocky Ellingsworth. He noted that although there were no fees or fines associated with the citation, the Commission has taken corrective active by updating its safety policy, as well as provide further training. In addition, the Commission would be preparing a letter to the Illinois Department of Labor which would state the abatement steps taken and include all supportive documentation in an effort to close the case.

Next, General Manager Spatz referred back to the December 2018 meeting in which employee salary adjustments had been discussed and approved based upon comparisons to other cities. It was also decided that the General Manager would hold on employee cost of living increases until the summer of 2019. With that said, General Manager Spatz noted that he had researched the 2019 national averages and found that the average increase was at 3% with averages being slightly higher for the year 2020. Since salary adjustments were approved back in December, General Manager Spatz recommended a 2% cost of living increase starting July 1st and asked for a consensus to move forward with the increase. With no further comments, it was the consensus of the Board members to authorize the General Manager to move forward with a 2% employee cost of living salary increase beginning July 1, 2019.

Lastly, General Manager Spatz referred to the Lead Legislation going on in Springfield noting that language had been included in the legislation to prevent water systems from passing any lead related costs onto the consecutive systems. Unfortunately, that piece of legislation had died, for now, due to funding issues. General Manager Spatz added how well respected the Commission's consultant John Millner is and how he made sure staff was introduced to the right people to get this accomplished.

NEW BUSINESS

None

EXECUTIVE SESSION

None

Commissioner Healy moved to adjourn the meeting at 6:50 P.M. Seconded by Commissioner Gans and unanimously approved by a Voice Vote.

All voted aye. Motion carried.

**DUPAGE WATER COMMISSION
INTEROFFICE MEMORANDUM**

TO: Chairman and Commissioners
FROM: Bill Fates, Treasurer
DATE: July 9, 2019
SUBJECT: TREASURER'S REPORT – June 30, 2019

I am pleased to report that I have reviewed and approved all journal entries and bank reconciliations for the month of June. I have also reviewed the monthly financial statements and budget status reports, and found them to be in order.

Summary of Cash & Investments (Page 4)

1. Cash and investments totaled \$172.6 million at June 30th, an increase of \$0.5 million compared to the previous month.
2. The balance in the BMO Harris checking account was \$18.8 million at June 30th, up \$0.4 million compared to the \$18.4 million reported last month.
3. The BMO Harris money market accounts had \$12.5 million at month-end, relatively unchanged from the prior month balance.
4. During the month of June, the IIIT money market accounts increased by approximately \$0.3 million from the prior month.
5. In June, our holdings of asset backed securities increased by \$4.2 million and U.S. Treasury and U.S. Agency investments decreased by \$2.3 million and \$2.1 million, respectively.
6. The current holdings of cash and investments are in compliance with the approved investment policy.
7. For the two months ended June 30, 2019, the Commission's cash and investments increased a total of \$1.4 million.
 - The Operating & Maintenance Account increased by 1.1 million for an ending balance of \$31.3 million.
 - The General Account increased by approximately \$51,000 for an ending balance of \$11.7 million.
 - The Sales Tax Account remained unchanged at \$286.
 - The Capital Reserve Fund increased by about \$98,000 for a balance of \$45.8 million.
 - The Operating Reserve Account increased \$143,000 for a balance of \$66.7 million.

- The Long-Term Capital Reserve Account increased by \$63,000 for a balance of \$17.1 million.

The following table presents a summary of the changes in cash position by account.

Cash and Investments by Account

Account	Balance 4/30/2019	Balance 06/30/2019	Increase (Decrease)
Operations & Maintenance	\$30,247,871	\$31,332,527	\$1,084,656
General Account	11,602,893	11,653,904	51,011
Sales Tax	285	286	1
Operating Reserve	66,581,413	66,724,314	142,901
Capital Reserve	45,676,743	45,775,168	98,425
Long-Term Cap. Reserve	17,042,753	17,105,701	62,948
Total Cash & Investments	\$171,151,958	\$172,591,900	\$1,439,942

Schedule of Investments (Pages 5-10)

1. The average yield to maturity on the Commission's investments was 2.18%, a slight increase from the prior month average yield to maturity of 2.17%.
2. The portfolio ended the month of June 2019 with \$1.2 million of unrealized gains, compared to \$0.4 million in unrealized losses at April 30, 2019.
3. The amortized cost of our investments was \$153.8 million at June 30th.

Statement of Cash Flows (Page 11)

1. The statement of cash flows shows a breakdown of the \$1.4 million increase in cash and investments for the fiscal year.
2. Operating activities generated \$1.0 million as of the end of June 2019.
3. The increase in Loans Receivable, primarily related to Bartlett activity, decreased cash by approximately \$65,000.
4. Capital Assets purchased were \$52,000.
5. Cash flow from investment activity generated \$0.5 million of income.

Reserve Analysis (Page 12)

1. The reserve analysis report shows the Commission has met or exceeded all recommended reserve balances at June 30th.
2. The Operating and Maintenance Account was \$31.3 million which is a balance currently sufficient enough to cover an estimated 86 days of normal operation and maintenance costs.
3. The Operating Reserve account was \$66.7 million which is approximately 183 days, this amount meets the minimum balance per the reserve policy.

Respectfully submitted,



Bill Fates, CPA
Treasurer

DU PAGE WATER COMMISSION
 TREASURER'S REPORT
 SUMMARY OF CASH AND INVESTMENTS
 June 30, 2019

FUNDS CONSIST OF:	June 30, 2019	May 31, 2019	INCR. - (DECR.)
PETTY CASH	1,300.00	1,300.00	0.00
CASH AT HARRIS BANK	18,813,344.43	18,405,405.86	407,938.57
TOTAL CASH	18,814,644.43	18,406,705.86	407,938.57
IIIT MONEY MARKET FUNDS	7,162,177.04	6,889,995.05	272,181.99
BMO HARRIS MONEY MARKET FUNDS	12,517,882.39	12,491,580.26	26,302.13
U. S. TREASURY INVESTMENTS	72,913,242.91	75,208,058.13	(2,294,815.22)
U. S. AGENCY INVESTMENTS	24,984,777.78	27,081,570.00	(2,096,792.22)
MUNICIPAL BONDS	5,482,350.37	5,482,733.73	(383.36)
COMMERCIAL PAPER	3,490,485.35	3,483,120.76	7,364.59
ASSET BACKED SEC/COLLATERALIZED MORTGAGE OBLIG	27,226,339.71	23,020,541.87	4,205,797.84
CERTIFICATES OF DEPOSIT	0.00	0.00	0.00
TOTAL INVESTMENTS	153,777,255.55	153,657,599.80	119,655.75
TOTAL CASH AND INVESTMENTS	172,591,899.98	172,064,305.66	527,594.32
	June 30, 2019	May 31, 2019	% CHANGE
IIIT MONEY MARKET FUNDS	4.7%	4.5%	4.0%
BMO HARRIS MONEY MARKET FUNDS	8.1%	8.1%	0.2%
U. S. TREASURY INVESTMENTS	47.4%	48.9%	-3.1%
U. S. AGENCY INVESTMENTS	16.2%	17.6%	-7.7%
MUNICIPAL BONDS	3.6%	3.6%	0.0%
COMMERCIAL PAPER	2.3%	2.3%	0.2%
ASSET BACKED SEC/COLLATERALIZED MORTGAGE OBLIG	17.7%	15.0%	18.3%
CERTIFICATES OF DEPOSIT	0.0%	0.0%	N/A
TOTAL INVESTMENTS	100.0%	100.0%	0.1%

Note 1 - Investments are carried at amortized cost.

DU PAGE WATER COMMISSION
 INVESTMENTS
 (Unaudited)
 June 30, 2019

FUND SOURCE	COUPON RATE	PURCHASE DATE	MATURITY DATE		YIELD TO MATURITY (COST)	PAR VALUE	PURCHASE PRICE	AMORTIZED DISCOUNT (PREMIUM)	AMORTIZED COST	ACCRUED INTEREST 06/30/19
Water Fund Oper. & Maint. Acct. (01-121103)										
BMO Harris - Money Market	2.590%	06/30/19	07/01/19	1	2.590%	\$ 12,517,882.39	\$ 12,517,882.39	0.00	\$ 12,517,882.39	-
Water Fund General Account (01-121700)										
III - Money Market	2.390%	06/30/19	07/01/19	1	2.390%	6,488,558.92	6,488,558.92	0.00	6,488,558.92	-
FNMA Notes	0.875%	08/31/16	08/28/19	59	1.050%	1,675,000.00	1,672,387.00	2,472.74	1,674,859.74	5,722.92
American Honda Finance CP	0.000%	04/25/19	07/25/19	25	2.500%	1,750,000.00	1,739,029.44	8,077.23	1,747,106.67	-
MUFG Bank LTD/ NY Commercial Paper	0.000%	04/25/19	08/23/19	54	2.590%	1,750,000.00	1,735,008.33	8,370.35	1,743,378.68	-
			Weighted Avg Maturity		2.244%	\$ 11,663,558.92	\$ 11,634,983.69	18,920.32	\$ 11,653,904.01	\$ 5,722.92
Sales Tax Funds (01-123000)										
III - Money Market	2.390%	06/30/19	07/01/19	1	2.390%	286.15	286.15	0.00	286.15	-
			Weighted Avg Maturity		2.390%	\$ 286.15	\$ 286.15	0.00	\$ 286.15	\$ -

DU PAGE WATER COMMISSION
INVESTMENTS
(Unaudited)
June 30, 2019

FUND SOURCE	COUPON RATE	PURCHASE DATE	MATURITY DATE		YIELD TO MATURITY (COST)	PAR VALUE	PURCHASE PRICE	AMORTIZED DISCOUNT (PREMIUM)	AMORTIZED COST	ACCRUED INTEREST 06/30/19
Water Fund Operating Reserve (01-121800)										
IIIT - Money Market	2.390%	06/30/19	07/01/19	1	2.390%	316,636.50	316,636.50	0.00	316,636.50	-
US Treasury Notes	2.125%	12/30/15	08/31/20	428	1.740%	375,000.00	381,489.26	(4,818.80)	376,670.46	2,663.47
US Treasury Notes	2.625%	05/03/16	11/15/20	504	1.210%	250,000.00	265,507.81	(10,715.48)	254,792.33	838.15
US Treasury Notes	2.000%	03/24/16	11/30/20	519	1.380%	1,000,000.00	1,028,007.81	(19,356.18)	1,008,651.63	1,693.99
US Treasury Notes	2.375%	03/31/16	12/31/20	550	1.280%	775,000.00	813,931.64	(26,401.56)	787,530.08	50.02
US Treasury Notes	2.000%	07/06/16	02/28/21	609	0.920%	775,000.00	812,902.34	(24,129.16)	789,773.18	5,180.71
US Treasury Notes	1.250%	06/27/16	03/31/21	640	0.980%	1,265,000.00	1,281,108.99	(10,096.29)	1,271,012.70	3,974.73
US Treasury Notes	2.000%	01/05/17	05/31/21	701	1.870%	1,300,000.00	1,307,007.81	(3,883.62)	1,303,124.19	2,202.19
US Treasury Notes	2.000%	09/01/16	05/31/21	701	1.220%	1,950,000.00	2,020,078.13	(41,290.92)	1,978,787.21	3,303.28
US Treasury Notes	2.000%	12/05/16	08/31/21	793	1.930%	2,100,000.00	2,106,234.37	(3,301.03)	2,102,933.34	14,038.04
US Treasury Notes	1.250%	03/13/17	10/31/21	854	2.110%	205,000.00	197,232.42	3,758.50	200,990.92	431.73
US Treasury Notes	2.000%	08/30/17	10/31/21	854	1.640%	2,000,000.00	2,028,515.63	(12,309.27)	2,016,206.36	6,739.13
US Treasury Notes	1.750%	04/03/17	11/30/21	884	1.860%	850,000.00	845,882.82	1,939.08	847,821.90	1,259.90
US Treasury Notes	1.750%	10/03/17	11/30/21	884	1.860%	1,500,000.00	1,495,195.31	1,972.26	1,497,167.57	2,223.36
US Treasury Notes	2.125%	06/28/17	12/31/21	915	1.720%	4,000,000.00	4,070,781.25	(30,876.53)	4,039,904.72	230.98
US Treasury Notes	1.750%	08/01/17	02/28/22	974	1.780%	1,800,000.00	1,797,539.06	1,009.71	1,798,548.77	10,528.53
US Treasury Notes	1.750%	05/11/17	04/30/22	1,035	1.930%	1,050,000.00	1,040,935.55	3,796.79	1,044,732.34	3,095.79
US Treasury Notes	1.875%	01/02/18	09/30/22	1,188	2.240%	275,000.00	270,552.73	1,349.87	271,902.60	1,296.11
US Treasury Notes	2.125%	09/05/18	12/31/22	1,280	2.770%	1,175,000.00	1,144,248.05	5,568.32	1,149,816.37	67.85
US Treasury Notes	1.750%	06/04/18	01/31/23	1,311	2.760%	3,600,000.00	3,442,640.63	34,460.52	3,477,101.15	26,279.01
US Treasury Notes	1.375%	12/10/18	08/30/23	1,461	2.710%	1,000,000.00	943,085.94	6,568.19	949,654.13	37.36
US Treasury Notes	2.250%	01/29/19	12/31/23	1,645	2.560%	1,270,000.00	1,251,991.80	1,454.40	1,253,446.20	77.65
US Treasury Notes	2.750%	02/28/19	02/15/24	1,691	2.460%	1,330,000.00	1,347,767.97	(1,154.39)	1,346,613.58	13,740.88
US Treasury Notes	2.375%	03/01/19	02/29/24	1,705	2.560%	550,000.00	545,208.98	291.40	545,500.38	4,366.00
US Treasury Notes	2.125%	04/01/19	03/31/24	1,736	2.300%	1,050,000.00	1,041,140.63	410.11	1,041,550.74	5,608.61
US Treasury Notes	2.000%	05/28/19	04/30/24	1,766	2.100%	1,420,000.00	1,413,121.88	124.98	1,413,246.86	4,784.78
US Treasury Notes	2.500%	06/03/19	05/15/24	1,781	1.900%	1,200,000.00	1,233,843.75	(462.39)	1,233,381.36	3,831.52
African Development Bank Note	1.125%	09/14/16	09/20/19	82	1.160%	505,000.00	504,464.70	495.58	504,960.28	1,593.91
Intl Bank of Recons and Dev Notes (World Bank)	1.625%	03/14/16	03/09/21	618	1.730%	925,000.00	920,597.00	2,869.96	923,466.96	4,676.39
Intl Bank of Recons and Dev Notes Global Notes	2.750%	07/18/18	07/23/21	754	2.830%	790,000.00	788,151.40	559.23	788,710.63	9,534.86
FL ST Board Admin Fin Corp Taxable Rev Bonds	2.163%	03/08/16	07/01/19	1	2.160%	925,000.00	925,000.00	0.00	925,000.00	10,003.88
CT ST Taxable GO Bonds	1.300%	08/03/16	08/15/19	46	1.230%	710,000.00	711,533.60	(1,470.05)	710,063.55	3,486.89
MS ST Taxable GO Bonds	1.679%	02/18/15	10/01/19	93	1.680%	310,000.00	310,000.00	0.00	310,000.00	1,301.23
NY Trans Fin Auth, NY Txb Rev Bonds	2.750%	04/23/15	02/01/20	216	1.880%	375,000.00	389,816.25	(12,935.18)	376,881.07	4,296.88
NY ST Dom Auth Pts Txb Rev Bonds	3.100%	12/12/18	03/15/21	624	3.100%	610,000.00	610,000.00	0.00	610,000.00	5,567.94
NY Trans Fin Auth, NY Txb Rev Bonds	1.500%	07/14/16	05/01/21	671	1.500%	600,000.00	600,000.00	0.00	600,000.00	1,500.00

DU PAGE WATER COMMISSION
INVESTMENTS
(Unaudited)
June 30, 2019

FUND SOURCE	COUPON RATE	PURCHASE DATE	MATURITY DATE	YIELD TO MATURITY (COST)	PAR VALUE	PURCHASE PRICE	AMORTIZED DISCOUNT (PREMIUM)	AMORTIZED COST	ACCRUED INTEREST 06/30/19		
Water Fund Operating Reserve (01-121800) Continued...											
FHMS K731 A1	3.481%	04/13/18	04/25/24	1,761 2.740%	339,842.95	346,639.82	(1,435.23)	345,204.59	985.83		
FNMA Pool #AJ3174	3.500%	02/17/16	10/01/26	2,850 2.270%	213,829.63	227,193.99	(2,943.21)	224,250.78	623.67		
FNMA Pool #AT3221	3.500%	06/17/16	03/01/27	2,801 2.270%	233,051.52	247,762.90	(2,713.60)	245,049.30	679.73		
FN AL2092	3.000%	03/06/18	07/25/27	2,947 2.900%	425,323.94	425,855.81	(124.76)	425,730.85	1,063.31		
FN AP4718	2.500%	07/20/18	08/25/27	2,978 2.960%	296,270.77	290,391.85	428.85	290,820.50	617.23		
Fannie Mae Pool	3.500%	04/05/18	02/01/28	3,138 2.770%	581,719.97	584,990.46	(2,363.39)	592,627.07	1,696.68		
Fannie Mae Pool	3.500%	04/05/18	03/01/28	3,167 2.780%	116,052.05	120,745.11	(487.36)	120,257.75	344.32		
FN CA1940	4.000%	07/11/18	06/01/28	3,259 3.080%	441,649.88	454,761.35	(1,903.04)	452,858.31	1,472.17		
FNMA Pool #AU1266	3.000%	10/31/17	07/25/28	3,313 2.240%	471,760.18	483,775.31	(1,142.50)	482,632.81	1,179.40		
Fannie Mae Pool	4.000%	03/18/19	03/25/29	3,556 3.050%	306,528.10	315,963.42	(411.54)	315,551.88	1,021.76		
FNMA Pool #AS4197	3.500%	07/16/15	01/01/30	3,838 2.620%	195,551.74	207,040.42	(2,555.51)	204,484.91	570.36		
FHLMC Pool #U49048	3.000%	03/17/16	08/01/30	4,050 2.350%	308,068.50	321,594.62	(2,368.50)	319,226.12	770.17		
FNMA Pool #AL7738	3.500%	02/17/16	11/01/30	4,142 2.550%	311,452.62	331,648.36	(4,204.69)	327,443.67	908.40		
FG G16720	3.500%	01/25/19	11/15/31	4,521 3.110%	345,489.94	351,050.17	(258.62)	350,791.55	1,007.68		
FG G16635	3.000%	04/18/19	02/15/32	4,613 2.790%	559,374.79	563,810.46	(74.86)	563,735.60	1,398.44		
Fannie Mae Pool	3.500%	02/13/18	01/25/33	4,958 2.980%	519,191.31	531,197.60	(1,667.65)	529,529.95	1,514.31		
Freddie Mac Pool	4.000%	06/07/18	02/15/33	4,979 3.260%	246,876.59	254,321.47	(827.89)	253,493.58	822.92		
FN CA1455	4.000%	12/20/18	03/25/33	5,017 3.290%	534,603.70	548,511.75	(736.68)	547,775.07	1,782.01		
FN CA2261	4.000%	02/05/19	08/01/33	5,146 3.130%	298,226.58	307,918.95	(412.13)	307,506.82	994.09		
Fannie Mae Pool	4.000%	03/01/19	02/25/34	5,354 3.240%	643,424.61	662,023.61	(752.77)	661,270.84	2,144.75		
FN BM5830	3.500%	06/05/19	04/25/34	5,413 2.540%	648,908.79	673,242.87	(54.48)	673,188.39	1,892.65		
Fannie Mae Series 2015-M13 ASQ2	1.646%	10/30/15	09/01/19	63 1.080%	770.43	778.14	(7.71)	770.43	1.06		
FHLMC Multifamily Structured Pool	4.251%	06/12/18	01/25/20	209 1.570%	514,664.41	525,118.53	(6,965.89)	518,152.64	1,823.20		
Fannie Mae Series 2016-M1 ASQ2	2.132%	01/29/16	02/01/21	582 1.680%	483,319.41	488,144.08	(3,845.75)	484,298.33	856.70		
FHMS KJ23 A1	3.174%	12/07/18	03/01/22	975 3.050%	754,491.38	754,485.35	(0.01)	754,485.34	1,995.63		
FHLMC Multifamily Structured Pool	2.396%	03/28/19	06/25/22	1,091 2.440%	600,000.00	598,640.63	28.86	598,669.49	1,198.00		
FHLMC Multifamily Structured Pool	2.716%	04/02/19	06/25/22	1,091 2.460%	650,000.00	651,625.00	(187.32)	651,437.68	1,471.17		
FHLMC Multifamily Structured Pool	2.682%	06/13/19	10/25/22	1,213 1.700%	650,000.00	659,750.00	0.00	659,750.00	1,452.75		
FHLMC Multifamily Structured Pool	2.510%	06/12/19	11/25/22	1,244 1.920%	650,000.00	655,687.50	0.00	655,687.50	1,359.58		
FHLMC Series K032 A1	3.018%	06/13/18	02/01/23	1,312 2.880%	192,048.91	192,506.53	(210.06)	192,296.47	482.68		
FHLMC Multifamily Structured Pool	2.669%	06/13/18	02/25/23	1,336 2.810%	217,944.79	216,829.54	148.26	216,977.80	484.75		
FHMS J22F A1	3.454%	11/07/18	05/25/23	1,425 3.280%	336,961.75	336,952.67	(0.02)	336,952.65	969.89		
FHMS KP05 A1	3.203%	12/07/18	07/01/23	1,462 3.110%	274,317.49	274,316.66	0.01	274,316.67	732.20		
FHLMC Multifamily Structured Pool	2.741%	10/31/17	10/25/23	1,578 2.010%	633,176.72	645,839.00	(3,609.89)	642,229.11	1,446.28		
FHLMC Multifamily Structured Pool	2.951%	12/15/17	02/25/24	1,701 2.240%	624,415.29	636,881.77	(3,168.34)	633,713.43	1,535.54		
FHMS K732 A1	3.627%	06/20/18	09/25/24	1,914 2.900%	340,969.13	347,783.75	(1,109.70)	346,674.05	1,030.58		
FNA 2017-M15 AV1	2.723%	11/30/17	11/25/24	1,975 2.230%	70,139.31	70,986.73	(159.88)	70,826.85	159.16		
FHMS K047 A1	2.827%	06/18/19	12/25/24	2,005 2.140%	659,377.20	670,710.26	0.00	670,710.26	1,553.38		
FHLMC Multifamily Structured Pool	3.139%	04/11/19	06/25/25	2,187 2.420%	688,388.21	702,155.28	(375.25)	701,780.03	1,800.71		
FHS 287 150	1.500%	12/21/17	10/15/27	3,029 2.480%	477,757.70	463,424.96	1,081.04	464,506.00	597.20		
Freddie Mac	3.000%	05/03/19	04/15/34	5,403 2.860%	639,639.87	642,788.10	(71.15)	642,716.95	1,599.10		
FHLMC Agency	1.375%	04/19/17	04/20/20	295 1.490%	1,075,000.00	1,071,323.50	2,677.13	1,074,000.63	2,915.19		
FHLB Notes	1.375%	09/08/17	09/28/20	456 1.480%	600,000.00	598,074.00	1,132.52	599,206.52	2,131.25		
FHLB Global Note	1.125%	08/02/16	07/14/21	745 1.210%	1,000,000.00	996,160.00	2,232.64	998,392.64	5,218.75		
FHLB Global Note	1.125%	07/14/16	07/14/21	745 1.250%	1,525,000.00	1,515,726.48	5,425.41	1,521,151.89	7,958.59		
Federal Home Loan Banks Notes	3.000%	09/13/18	09/20/21	813 3.000%	1,335,000.00	1,335,000.00	0.00	1,335,000.00	11,236.25		
Fannie Mae Notes	1.875%	04/06/17	04/05/22	1,010 1.970%	1,120,000.00	1,114,971.20	2,183.27	1,117,154.47	5,016.67		
FHLB (Callable) Notes	2.700%	05/02/19	04/29/22	1,034 2.700%	320,000.00	320,000.00	0.00	320,000.00	1,488.00		
Fannie Mae Notes	2.500%	02/07/19	02/05/24	1,681 2.580%	930,000.00	926,540.40	258.82	926,799.22	9,235.42		
FHLB Bonds	2.500%	02/14/19	02/13/24	1,689 2.580%	1,020,000.00	1,016,389.20	257.05	1,016,646.25	9,633.33		
				Weighted Avg Maturity	1.440	2.123%	\$ 66,554,216.66	\$ 66,892,181.17	(167,867.47)	\$ 66,724,313.70	\$ 261,380.64

DU PAGE WATER COMMISSION
INVESTMENTS
(Unaudited)
June 30, 2019

FUND SOURCE	COUPON RATE	PURCHASE DATE	MATURITY DATE		YIELD TO MATURITY (COST)	PAR VALUE	PURCHASE PRICE	AMORTIZED DISCOUNT (PREMIUM)	AMORTIZED COST	ACCRUED INTEREST 06/30/19
Water Fund L-T Water Capital Reserve (01-121900)										
IIIT - Money Market (PFM Asset Management)	2.390%	06/30/19	07/01/19	1	2.390%	134,831.94	134,831.94	0.00	134,831.94	-
US Treasury Notes	2.500%	06/04/18	05/31/20	336	2.510%	85,000.00	84,990.04	5.39	84,995.43	179.99
US Treasury Notes	1.750%	02/03/16	10/31/20	489	1.350%	250,000.00	254,628.91	(3,298.32)	251,330.59	737.09
US Treasury Notes	2.000%	03/28/16	11/30/20	519	1.380%	265,000.00	272,442.77	(5,138.62)	267,304.15	448.91
US Treasury Notes	1.625%	11/14/16	11/30/20	519	1.400%	320,000.00	322,800.00	(1,801.88)	320,998.12	440.44
US Treasury Notes	2.000%	03/28/16	10/31/21	854	1.520%	275,000.00	282,014.65	(4,016.69)	277,997.96	926.63
US Treasury Notes	1.875%	01/12/15	11/30/21	884	1.780%	260,000.00	261,675.78	(1,063.66)	260,612.12	412.91
US Treasury Notes	1.500%	12/30/15	01/31/22	946	2.040%	75,000.00	72,697.27	1,291.10	73,988.37	469.27
US Treasury Notes	1.500%	09/03/15	01/31/22	946	1.870%	350,000.00	342,234.38	4,524.74	346,759.12	2,189.92
US Treasury Notes	1.875%	05/01/19	04/30/22	1,035	2.230%	500,000.00	494,863.28	272.06	495,135.34	1,579.48
US Treasury Notes	1.625%	02/26/15	08/15/22	1,142	1.820%	175,000.00	172,662.11	1,321.76	173,983.87	1,068.37
US Treasury Notes	1.625%	12/04/15	11/15/22	1,234	1.930%	200,000.00	196,109.38	1,938.13	198,047.51	415.08
US Treasury Notes	1.500%	02/01/17	03/31/23	1,370	2.210%	425,000.00	407,800.78	6,455.96	414,256.74	1,602.46
US Treasury Notes	1.750%	04/24/15	05/15/23	1,415	1.790%	195,000.00	194,390.62	306.03	194,696.65	435.84
US Treasury Notes	1.375%	08/31/17	06/30/23	1,461	1.850%	175,000.00	170,378.91	1,401.12	171,780.03	6.54
US Treasury Notes	1.375%	09/01/16	08/31/23	1,523	1.470%	125,000.00	124,208.99	310.24	124,519.23	574.47
US Treasury Notes	1.375%	01/03/17	08/31/23	1,523	2.240%	200,000.00	189,320.31	3,806.64	193,126.95	919.16
US Treasury Notes	2.750%	12/05/16	11/15/23	1,599	2.260%	60,000.00	61,877.34	(661.32)	61,212.02	210.73
US Treasury Notes	2.750%	03/28/16	11/15/23	1,599	1.720%	150,000.00	160,974.61	(4,511.70)	156,462.91	526.83
US Treasury Notes	2.750%	10/09/15	11/15/23	1,599	1.910%	155,000.00	164,766.21	(4,308.51)	160,457.70	544.40
US Treasury Notes	2.750%	05/26/16	11/15/23	1,599	1.650%	275,000.00	296,097.66	(8,414.28)	287,683.38	965.86
US Treasury Notes	2.750%	10/05/16	02/15/24	1,691	1.460%	75,000.00	81,738.28	(2,421.47)	79,316.81	774.86
US Treasury Notes	2.750%	05/09/19	04/30/24	1,766	2.220%	500,000.00	500,605.47	(15.93)	500,589.54	1,895.38
US Treasury Notes	2.500%	03/16/17	05/15/24	1,781	2.450%	300,000.00	300,960.94	(286.05)	300,674.89	957.88
US Treasury Notes	2.500%	06/03/19	05/15/24	1,781	1.900%	350,000.00	359,871.09	(134.86)	359,736.23	1,117.53
US Treasury Notes	2.000%	06/28/17	05/31/24	1,797	1.970%	285,000.00	285,545.51	(149.40)	285,396.11	482.79
US Treasury Notes	2.375%	03/28/16	08/15/24	1,873	1.810%	200,000.00	208,679.69	(3,219.02)	205,460.67	1,784.53
US Treasury Notes	2.375%	08/02/17	08/15/24	1,873	2.070%	200,000.00	204,039.06	(1,038.88)	203,000.18	1,784.53
US Treasury Notes	2.125%	12/01/17	11/30/24	1,980	2.280%	475,000.00	470,416.99	969.22	471,386.21	854.94
US Treasury Notes	2.125%	05/03/16	05/15/25	2,146	1.760%	150,000.00	154,558.59	(1,511.15)	153,047.44	407.10
US Treasury Notes	2.875%	07/02/18	05/31/25	2,162	2.830%	250,000.00	250,732.42	(93.68)	250,638.74	608.78
US Treasury Notes	2.250%	07/06/16	11/15/25	2,330	1.320%	105,000.00	113,613.28	(2,631.11)	110,982.17	301.73
US Treasury Notes	2.250%	06/27/16	11/15/25	2,330	1.450%	115,000.00	123,036.52	(2,457.71)	120,578.81	330.47
US Treasury Notes	1.625%	06/04/18	05/15/26	2,511	2.930%	250,000.00	227,099.61	2,790.68	229,890.29	518.85
US Treasury Notes	1.625%	09/10/18	05/15/26	2,511	2.900%	275,000.00	250,980.47	2,280.20	253,260.67	570.74
US Treasury Notes	1.500%	11/06/18	08/15/26	2,603	3.160%	150,000.00	132,949.22	1,270.64	134,219.86	845.30
US Treasury Notes	2.000%	12/04/18	11/15/26	2,695	2.920%	225,000.00	210,445.31	938.95	211,384.26	574.73
US Treasury Notes	2.250%	06/04/18	08/15/27	2,968	2.950%	250,000.00	236,035.16	1,446.25	237,481.41	2,113.26
US Treasury Notes	2.250%	05/01/19	11/15/27	3,060	2.440%	250,000.00	246,328.13	64.82	246,392.95	718.41
US Treasury Notes	2.750%	01/30/19	02/15/28	3,152	2.710%	250,000.00	250,722.66	(27.94)	250,694.72	2,582.87
US Treasury Notes	3.125%	05/01/19	02/15/28	3,152	2.470%	150,000.00	158,320.31	(126.48)	158,193.83	598.68
US Treasury Notes	2.625%	06/03/19	02/15/29	3,518	2.120%	100,000.00	104,406.25	(28.49)	104,377.76	877.38
US Treasury Notes	2.625%	04/01/19	02/15/29	3,518	2.490%	150,000.00	151,769.53	(37.40)	151,732.13	1,316.07
Intl Bank of Recons and Dev Notes (World Bank)	1.625%	03/14/16	03/09/21	618	1.730%	150,000.00	149,286.00	465.40	149,751.40	758.33
Asian Development Bank Note	1.625%	03/16/16	03/16/21	625	1.640%	150,000.00	149,884.50	74.98	149,959.48	710.94
Intl Bank of Recons and Dev Notes Global Notes	2.750%	07/18/18	07/23/21	754	2.830%	250,000.00	249,415.00	176.97	249,591.97	3,017.36
FL ST Board Admin Fin Corp Taxable Rev Bonds	2.163%	03/08/16	07/01/19	1	2.160%	150,000.00	150,000.00	0.00	150,000.00	1,622.25
MS ST Taxable GO Bonds	1.679%	02/18/15	10/01/19	93	1.680%	40,000.00	40,000.00	0.00	40,000.00	167.90
NY Trans Fin Auth, NY Txbi Rev Bonds	2.750%	04/23/15	02/01/20	216	1.880%	75,000.00	77,963.25	(2,587.04)	75,376.21	859.38
CT ST Taxable GO Bonds	2.294%	03/25/15	03/15/20	259	2.290%	70,000.00	70,000.00	0.00	70,000.00	472.82
UNIV OF CAL Taxable Rev Bonds	2.253%	03/25/15	05/15/20	320	2.250%	50,000.00	50,000.00	0.00	50,000.00	143.94
NY Trans Fin Auth, NY Txbi Rev Bonds	1.500%	07/14/16	05/01/21	671	1.500%	100,000.00	100,000.00	0.00	100,000.00	250.00
NY ST Dorm Auth Pits Txbi Rev Bonds	3.250%	12/12/18	03/15/23	1,354	3.250%	180,000.00	180,000.00	0.00	180,000.00	1,722.50

DU PAGE WATER COMMISSION
INVESTMENTS
(Unaudited)
June 30, 2019

FUND SOURCE	COUPON RATE	PURCHASE DATE	MATURITY DATE		YIELD TO MATURITY (COST)	PAR VALUE	PURCHASE PRICE	AMORTIZED DISCOUNT (PREMIUM)	AMORTIZED COST	ACCRUED INTEREST 06/30/19
Water Fund L-T Water Capital Reserve (01-121900) Continued...										
FNMA Pool #AJ3174	3.500%	02/17/16	10/01/26	2,650	2.270%	34,249.77	36,390.36	(471.40)	35,918.96	99.90
FNMA Pool #AT3221	3.500%	06/17/16	03/01/27	2,801	2.270%	42,588.08	45,276.44	(495.87)	44,780.57	124.22
FNMA Pool #AU1266	3.000%	10/31/17	07/25/28	3,313	2.240%	108,867.73	111,640.47	(263.67)	111,376.80	272.17
Fannie Mae Pool	4.000%	03/18/19	03/25/29	3,556	3.050%	65,021.10	67,022.54	(87.31)	66,935.23	216.74
FNMA Pool #AS4197	3.500%	07/16/15	01/01/30	3,838	2.620%	48,312.79	51,151.17	(631.36)	50,519.81	140.91
FHLMC Pool #U49048	3.000%	03/17/16	08/01/30	4,050	2.350%	46,210.27	48,239.19	(355.28)	47,883.91	115.53
FNMA Pool #AL7738	3.500%	02/17/16	11/01/30	4,142	2.550%	51,404.82	54,738.11	(693.99)	54,044.12	149.93
FG G16635	3.000%	04/18/19	02/15/32	4,613	2.790%	119,866.02	120,816.52	(16.04)	120,800.48	299.67
FN BM5462	3.000%	06/21/19	11/25/32	4,897	2.450%	164,323.83	168,046.80	(0.01)	168,046.79	410.81
Freddie Mac Pool	4.000%	06/07/18	02/15/33	4,979	3.260%	75,961.99	78,252.71	(254.72)	77,997.99	253.21
FN CA1455	4.000%	12/20/18	03/25/33	5,017	3.290%	119,824.97	122,942.28	(165.11)	122,777.17	399.42
FN CA2261	4.000%	02/05/19	08/01/33	5,146	3.130%	63,905.70	65,982.64	(88.32)	65,894.32	213.02
Fannie Mae Pool	4.000%	03/01/19	02/25/34	5,354	3.240%	131,502.84	135,304.10	(153.86)	135,150.24	438.34
FN BM5830	3.500%	06/05/19	04/25/34	5,413	2.540%	162,227.20	168,310.72	(13.62)	168,297.10	473.16
Fannie Mae Series 2015-M13 ASQ2	1.646%	10/30/15	09/01/19	63	1.080%	145.01	146.46	(1.45)	145.01	0.20
Fannie Mae Series 2016-M1 ASQ2	2.132%	01/29/16	02/01/21	582	1.680%	91,438.80	92,351.58	(727.58)	91,624.00	162.46
FHMS J2F A1	3.454%	11/07/18	05/25/23	1,425	3.280%	11,356.61	71,354.70	(0.02)	71,354.68	205.39
FHMS KP05 A1	3.203%	12/07/18	07/01/23	1,462	3.110%	57,518.19	57,518.02	0.00	57,518.02	153.53
FHLMC Multifamily Structured Pool	2.741%	10/31/17	10/25/23	1,578	2.010%	121,764.76	124,199.81	(694.20)	123,505.61	278.13
FHLMC Multifamily Structured Pool	2.951%	12/15/17	02/25/24	1,701	2.240%	192,127.79	195,963.62	(974.86)	194,988.76	472.47
FHMS K732 A1	3.627%	06/20/18	09/25/24	1,914	2.900%	97,419.76	99,366.79	(317.05)	99,049.74	294.45
FHMS K047 A1	2.827%	06/18/19	12/25/24	2,005	2.140%	168,769.16	171,669.89	0.00	171,669.89	397.59
FHLMC Multifamily Structured Pool	3.139%	04/11/19	06/25/25	2,187	2.420%	149,649.61	152,642.45	(81.57)	152,560.88	381.46
Freddie Mac	3.000%	05/03/19	04/15/34	5,403	2.860%	118,087.36	118,668.57	(13.13)	118,655.44	295.22
FNMA Notes	1.000%	10/19/16	08/28/19	59	1.040%	1,385,000.00	1,383,476.50	1,438.24	1,384,914.74	4,732.08
FHLB Global Note	1.125%	07/13/16	07/14/21	745	1.230%	250,000.00	248,767.50	721.51	249,489.01	1,304.69
Federal Home Loan Banks Notes	3.000%	09/13/18	09/20/21	813	3.000%	285,000.00	285,000.00	0.00	285,000.00	2,398.75
Fannie Mae Notes	1.875%	04/06/17	04/05/22	1,010	1.970%	500,000.00	497,755.00	974.68	498,729.68	2,239.58
FHLB (Callable) Notes	2.700%	05/02/19	04/29/22	1,034	2.700%	135,000.00	135,000.00	0.00	135,000.00	627.75
Fannie Mae Notes	2.500%	02/07/19	02/05/24	1,681	2.580%	195,000.00	194,274.60	54.27	194,328.87	1,936.46
FHLB Bonds	2.500%	02/14/19	02/13/24	1,689	2.580%	215,000.00	214,238.90	54.18	214,293.08	2,030.56
FNMA Notes	2.125%	04/26/16	04/24/26	2,490	2.210%	210,000.00	208,357.80	483.98	208,841.78	830.52
FNMA Notes	2.125%	06/04/18	04/24/26	2,490	3.070%	250,000.00	233,645.00	2,004.87	235,649.87	988.72
FNMA Benchmark Note	1.875%	12/20/18	09/24/26	2,643	2.970%	500,000.00	462,350.00	2,309.53	464,658.53	2,526.04
		Weighted Avg Maturity	1.723		2.151%	\$ 17,147,376.10	\$ 17,122,030.42	(16,329.47)	\$ 17,105,700.95	\$ 72,269.69
Capital Reserve (01-122000)										
IIIT - Money Market (PFM Asset Management)										
	2.390%	06/30/19	07/01/19	1	2.390%	221,863.53	221,863.53	0.00	221,863.53	-
US Treasury Notes	1.375%	05/08/17	05/31/20	336	1.570%	500,000.00	497,128.90	1,998.70	499,127.60	582.31
US Treasury Notes	1.625%	06/28/17	06/30/20	366	1.500%	3,300,000.00	3,311,988.28	(7,950.17)	3,304,038.11	145.72
US Treasury Notes	1.375%	08/30/17	08/31/20	428	1.450%	2,000,000.00	1,995,703.13	2,605.61	1,998,308.74	9,191.58
US Treasury Notes	1.375%	10/05/17	09/30/20	458	1.640%	1,620,000.00	1,607,533.59	7,182.47	1,614,716.06	5,599.18
US Treasury Notes	1.375%	11/01/17	10/31/20	489	1.770%	1,200,000.00	1,186,406.25	7,463.18	1,193,869.43	2,779.89
US Treasury Notes	2.000%	03/24/16	11/30/20	519	1.380%	1,000,000.00	1,028,007.82	(19,356.19)	1,008,651.63	1,693.99
US Treasury Notes	1.750%	12/01/17	12/31/20	550	1.910%	2,500,000.00	2,488,281.25	5,925.50	2,494,206.75	118.89
US Treasury Notes	1.375%	01/02/18	01/31/21	581	2.050%	750,000.00	735,029.30	7,146.74	742,176.04	4,301.62
US Treasury Notes	2.375%	03/11/19	04/15/21	655	2.470%	500,000.00	498,984.38	150.49	499,134.87	2,498.29
US Treasury Notes	2.625%	06/11/18	05/15/21	685	2.660%	500,000.00	499,531.25	168.17	499,699.42	1,676.29
US Treasury Notes	2.625%	07/02/18	05/15/21	685	2.640%	1,475,000.00	1,474,308.59	250.15	1,474,558.74	4,945.06
US Treasury Notes	1.125%	09/05/18	09/30/21	823	2.720%	535,000.00	510,005.47	6,467.97	516,473.44	1,512.91
US Treasury Notes	2.500%	01/29/19	01/15/22	930	2.550%	1,800,000.00	1,897,550.78	344.21	1,897,894.99	21,912.98
US Treasury Notes	1.500%	01/07/19	01/31/22	946	2.490%	2,500,000.00	2,427,343.75	10,932.40	2,438,276.15	15,642.27
US Treasury Notes	1.750%	03/07/19	02/28/22	974	2.460%	2,250,000.00	2,204,296.88	4,652.82	2,208,949.70	13,160.67
US Treasury Notes	2.250%	05/28/19	04/15/22	1,020	2.090%	820,000.00	823,683.59	(113.83)	823,569.76	3,881.56
US Treasury Notes	1.875%	05/01/19	04/30/22	1,035	2.230%	1,700,000.00	1,682,535.16	924.98	1,683,460.14	5,370.24
US Treasury Notes	1.875%	05/09/19	05/31/22	1,066	2.220%	2,000,000.00	1,979,843.75	921.35	1,980,765.10	3,176.23
US Treasury Notes	1.875%	06/03/19	05/31/22	1,066	1.850%	2,500,000.00	2,501,757.81	(40.51)	2,501,717.30	3,970.29
African Development Bank Note	1.125%	09/14/16	09/20/19	82	1.160%	235,000.00	234,750.90	230.61	234,981.51	741.72
Intl Bank of Recons and Dev Notes Global Notes	2.750%	07/18/18	07/23/21	754	2.830%	420,000.00	419,017.20	297.31	419,314.51	5,089.17

DU PAGE WATER COMMISSION
INVESTMENTS
(Unaudited)
June 30, 2019

FUND SOURCE	COUPON RATE	PURCHASE DATE	MATURITY DATE		YIELD TO MATURITY (COST)	PAR VALUE	PURCHASE PRICE	AMORTIZED DISCOUNT (PREMIUM)	AMORTIZED COST	ACCRUED INTEREST 06/30/19
Capital Reserve (01-122000) Continued...										
FL ST Board Admin Fin Corp Taxable Rev Bonds	2.163%	03/08/16	07/01/19	1	2.160%	600,000.00	600,000.00	0.00	600,000.00	6,489.00
CT ST Taxable GO Bonds	1.300%	08/03/16	08/15/19	46	1.230%	330,000.00	330,712.80	(683.26)	330,029.54	1,626.67
NY ST Dom Auth Pits Txbi Rev Bonds	3.100%	12/12/18	03/15/21	624	3.100%	355,000.00	355,000.00	0.00	355,000.00	3,240.36
FN AB8565	2.000%	04/09/18	03/25/23	1,364	2.520%	186,363.15	184,150.09	373.55	184,523.64	310.61
Fannie Mae Pool	3.500%	04/17/18	06/25/26	2,552	2.820%	376,883.00	383,714.00	(750.49)	382,963.51	1,089.24
Fannie Mae Pool	3.500%	04/17/18	08/25/26	2,613	2.830%	352,405.72	358,793.06	(681.65)	358,111.41	1,027.85
FN AL2092	3.000%	03/06/18	07/25/27	2,947	2.900%	324,128.16	324,531.34	(95.09)	324,436.25	810.32
Fannie Mae Pool	3.500%	04/05/18	02/25/28	3,162	2.770%	484,766.66	495,825.40	(1,969.49)	493,855.91	1,413.90
Fannie Mae Pool	3.500%	04/05/18	03/25/28	3,191	2.780%	275,454.80	281,738.62	(1,137.18)	280,601.44	803.41
Fannie Mae Pool	3.500%	04/05/18	04/25/28	3,222	2.820%	346,195.56	353,768.59	(1,396.61)	352,371.98	1,009.74
FN CA1940	4.000%	07/11/18	06/01/28	3,259	3.080%	319,670.40	329,160.61	(1,377.44)	327,783.17	1,065.57
Fannie Mae Pool	4.000%	03/18/19	03/25/29	3,556	3.050%	181,130.24	186,705.65	(243.18)	186,462.47	603.77
Fannie Mae Pool	4.000%	03/01/19	02/25/34	5,354	3.240%	375,722.40	386,583.12	(439.56)	386,143.56	1,252.41
Fannie Mae Series 2015-M13 ASQ2	1.646%	10/30/15	09/01/19	63	1.090%	498.50	503.49	(4.99)	498.50	0.68
Freddie Mac Series 4459 NB	4.500%	06/11/15	01/01/20	185	0.770%	56.14	58.86	(2.46)	56.40	0.21
FHMS K006 A2	4.251%	06/12/18	01/25/20	209	1.570%	372,519.01	380,085.80	(5,041.98)	375,043.82	1,319.65
FNMA Series 2015-M12 FA	0.540%	09/30/15	04/25/20	300	0.540%	5,295.09	5,293.19	1.90	5,295.09	12.86
FHMS KJ23 A1	3.174%	12/07/18	03/01/22	975	3.050%	391,943.58	391,940.44	0.00	391,940.44	1,036.69
FHLMC Multifamily Structured Pool	2.396%	04/02/19	06/25/22	1,091	2.440%	350,000.00	349,207.03	16.84	349,223.87	698.83
FHLMC Multifamily Structured Pool	2.396%	04/02/19	06/25/22	1,091	2.440%	350,000.00	349,207.03	16.84	349,223.87	698.83
FHLMC Multifamily Structured Pool	2.716%	04/02/19	06/25/22	1,091	2.460%	500,000.00	501,250.00	(144.09)	501,105.91	1,131.67
FHLMC Multifamily Structured Pool	2.682%	06/13/19	10/25/22	1,213	1.700%	450,000.00	456,750.00	0.00	456,750.00	1,005.75
FHLMC Multifamily Structured Pool	2.510%	06/12/19	11/25/22	1,244	1.920%	450,000.00	453,937.50	0.00	453,937.50	941.25
FHLMC Series K032 A1	3.016%	06/13/18	02/01/23	1,312	2.880%	139,235.46	139,567.23	(152.29)	139,414.94	349.95
FHLMC Multifamily Structured Pool	2.669%	06/13/18	02/25/23	1,336	2.810%	160,176.31	159,356.66	108.96	159,465.62	356.26
FHMS J22F A1	3.454%	11/07/18	05/25/23	1,425	3.280%	206,141.30	206,135.75	(0.02)	206,135.73	593.34
FHMS K047 A1	2.827%	06/18/19	12/25/24	2,005	2.140%	451,359.39	459,117.14	0.00	459,117.14	1,063.33
FNMA Notes	1.500%	07/28/17	07/30/20	396	1.600%	2,500,000.00	2,492,425.00	4,802.70	2,497,227.70	15,729.17
FHLB Notes	1.375%	09/08/17	09/28/20	456	1.480%	1,300,000.00	1,295,827.00	2,453.79	1,298,280.79	4,617.71
Fannie Mae Notes	2.875%	10/30/18	10/30/20	488	2.910%	1,500,000.00	1,499,130.00	284.63	1,499,414.63	7,307.29
Federal Home Loan Banks Notes	3.000%	09/13/18	09/20/21	813	3.000%	910,000.00	910,000.00	0.00	910,000.00	7,659.17
FHLB (Callable) Notes	2.700%	05/02/19	04/29/22	1,034	2.700%	905,000.00	905,000.00	0.00	905,000.00	4,208.25
Weighted Avg Maturity			895		2.149%	\$ 45,876,806.40	\$ 45,751,026.96	24,141.39	\$ 45,775,168.35	\$ 177,448.60
TOTAL ALL FUNDS					2.181%	\$153,760,126.62	\$153,918,390.78	(141,135.23)	\$ 153,777,255.55	\$ 516,821.85
Less: Net Unsettled Trades									\$ 153,777,255.55	
June 30, 2019					90 DAY US TREASURY YIELD		2.12%			
					3 month US Treasury Bill Index		2.09%			
					0-3 Year US Treasury Index		1.87%			
					1-3 Year US Treasury Index		1.80%			
					1-5 Year US Treasury Index		1.78%			
					1-10 Year US Treasury Index		1.80%			

DUPAGE WATER COMMISSION
ELMHURST, ILLINOIS
TREASURER'S REPORT
STATEMENT OF CASH FLOWS
For the Period from May 1, 2019 to June 30, 2019

CASH FLOWS FROM OPERATING ACTIVITIES

Cash received from customers	\$ 19,605,123
Cash payments to suppliers	(17,874,316)
Cash payments to employees	<u>(685,144)</u>
Net cash from operating activities	1,045,663

CASH FLOWS FROM NONCAPITAL
FINANCING ACTIVITIES

Cash received from sales taxes	0
Cash received/paid from long term loans	(65,195)
Cash payments for net pension activity	<u>0</u>
Net cash from noncapital financing activities	(65,195)

CASH FLOWS FROM CAPITAL AND
RELATED FINANCING ACTIVITIES

Interest paid	0
Principal Paid	0
Construction and purchase of capital assets	<u>(52,312)</u>
Net cash from capital and related financing activities	(52,312)

CASH FLOWS FROM INVESTING ACTIVITIES

Investment income	<u>511,787</u>
Net cash from investing activities	511,787

Net Increase (Decrease) in cash and investments 1,439,943

CASH AND INVESTMENTS, MAY 1, 2019 171,151,957

CASH AND INVESTMENTS, JUNE 30, 2019 \$ 172,591,900

June 30, 2019
 TREASURER'S REPORT
 DPWC MONTHLY CASH/OPERATING REPORT

	6/30/2019		
	YEAR END TARGETED Reserve or Monthly Cash Amount-Needed	Amount On Hand	Amount Over - (Under) Target
TABLE 1	A	B	C
RESERVE ANALYSIS			
A .Operating Reserve <i># of days per current fiscal year management budget</i>	\$ 65,791,115 180	\$ 66,724,314 183	\$ 933,199
B. Capital Reserve	\$ 44,739,500	\$ 44,904,372	\$ 164,872
C. Long Term Water Capital Reserve	\$ 16,225,000	\$ 17,105,701	\$ 880,701
D. O+M Account (1)	\$ 11,606,675	\$ 31,332,527	\$ 19,725,852
E. Current Construction Obligation and Customer Construction Escrows	\$ 870,796	\$ 870,796	\$ -
TOTAL SUMMARY CASH + RESERVE ANALYSIS	\$ 139,233,086	\$ 160,937,710	\$ 21,704,624

TABLE 2		
OTHER CASH		
F. General Fund		\$ 11,653,904
G. Sales Tax		\$ 286
TOTAL TABLE 2-OTHER CASH		\$ 11,654,190
TOTAL MONTH END FUNDS CASH BALANCE-Table1+2		\$ 172,591,900

Note 1: The O&M Account target varies from month to month. The cash balance should be enough to cover the current months operating cash outflows.

DUPAGE WATER COMMISSION INTEROFFICE MEMORANDUM

TO: Chairman and Commissioners
FROM: Bill Fates, Treasurer
DATE: August 6, 2019
SUBJECT: TREASURER'S REPORT – July 31, 2019

I am pleased to report that I have reviewed and approved all journal entries and bank reconciliations for the month of July. I have also reviewed the monthly financial statements and budget status reports, and found them to be in order.

Summary of Cash & Investments (Page 4)

1. Cash and investments totaled \$173.8 million at July 31st, an increase of \$1.2 million compared to the previous month.
2. The balance in the BMO Harris checking account was \$19.6 million at July 31st, up \$0.8 million compared to the \$18.8 million reported last month.
3. The BMO Harris money market accounts had \$12.5 million at month-end, relatively unchanged from the prior month balance.
4. During the month of July, the IIIT money market accounts increased by approximately \$2.4 million from the prior month.
5. In July, our holdings of U.S. Treasury investments increased by \$1.9 million, and municipal bonds and commercial paper investments decreased by \$1.7 million each.
6. The current holdings of cash and investments are in compliance with the approved investment policy.
7. For the three months ended July 31, 2019, the Commission's cash and investments increased a total of \$2.6 million.
 - The Operating & Maintenance Account increased by 1.9 million for an ending balance of \$32.2 million.
 - The General Account increased by approximately \$71,000 for an ending balance of \$11.7 million.
 - The Sales Tax Account remained unchanged at \$287.
 - The Capital Reserve Fund increased by about \$246,000 for a balance of \$45.9 million.
 - The Operating Reserve Account increased \$328,000 for a balance of \$66.9 million.

- The Long-Term Capital Reserve Account increased by \$77,000 for a balance of \$17.1 million.

The following table presents a summary of the changes in cash position by account.

Cash and Investments by Account

Account	Balance 4/30/2019	Balance 07/31/2019	Increase (Decrease)
Operations & Maintenance	\$30,247,871	\$32,175,332	\$1,927,461
General Account	11,602,893	11,674,124	71,231
Sales Tax	285	287	2
Operating Reserve	66,581,413	66,909,134	327,721
Capital Reserve	45,676,743	45,922,473	245,730
Long-Term Cap. Reserve	17,042,753	17,119,656	76,903
Total Cash & Investments	\$171,151,958	\$173,801,006	\$2,649,048

Schedule of Investments (Pages 5-10)

1. The average yield to maturity on the Commission's investments was 2.16%, a slight decrease from the prior month average yield to maturity of 2.18%.
2. The portfolio ended the month of July 2019 with \$0.8 million of unrealized gains, compared to \$0.4 million in unrealized losses at April 30, 2019.
3. The amortized cost of our investments was \$154.2 million at July 31st.

Statement of Cash Flows (Page 11)

1. The statement of cash flows shows a breakdown of the \$2.6 million increase in cash and investments for the fiscal year.
2. Operating activities generated \$2.2 million as of the end of June 2019.
3. The increase in Loans Receivable, primarily related to Bartlett activity, decreased cash by approximately \$372,000.
4. Capital Assets purchased were \$165,000.
5. Cash flow from investment activity generated \$1.0 million of income.

Reserve Analysis (Page 12)

1. The reserve analysis report shows the Commission has met or exceeded all recommended reserve balances at July 31st.
2. The Operating and Maintenance Account was \$32.2 million which is a balance currently sufficient enough to cover an estimated 88 days of normal operation and maintenance costs.
3. The Operating Reserve account was \$66.9 million which is approximately 183 days, this amount meets the minimum balance per the reserve policy.

Respectfully submitted,

Bill Fates

Bill Fates, CPA
Treasurer

DU PAGE WATER COMMISSION
 TREASURER'S REPORT
 SUMMARY OF CASH AND INVESTMENTS
 July 31, 2019

FUNDS CONSIST OF:	July 31, 2019	June 30, 2019	INCR. - (DECR.)
PETTY CASH	1,300.00	1,300.00	0.00
CASH AT HARRIS BANK	19,629,650.16	18,813,344.43	816,305.73
TOTAL CASH	19,630,950.16	18,814,644.43	816,305.73
IIIT MONEY MARKET FUNDS	9,574,503.26	7,162,177.04	2,412,326.22
BMO HARRIS MONEY MARKET FUNDS	12,544,382.23	12,517,882.39	26,499.84
U. S. TREASURY INVESTMENTS	74,765,020.83	72,913,242.91	1,851,777.92
U. S. AGENCY INVESTMENTS	24,986,651.79	24,984,777.78	1,874.01
MUNICIPAL BONDS	3,806,967.02	5,482,350.37	(1,675,383.35)
COMMERCIAL PAPER	1,747,251.52	3,490,485.35	(1,743,233.83)
ASSET BACKED SEC/COLLATERALIZED MORTGAGE OBLIG	26,745,278.72	27,226,339.71	(481,060.99)
CERTIFICATES OF DEPOSIT	0.00	0.00	0.00
TOTAL INVESTMENTS	154,170,055.37	153,777,255.55	392,799.82
TOTAL CASH AND INVESTMENTS	173,801,005.53	172,591,899.98	1,209,105.55
	July 31, 2019	June 30, 2019	% CHANGE
IIIT MONEY MARKET FUNDS	6.3%	4.7%	33.7%
BMO HARRIS MONEY MARKET FUNDS	8.1%	8.1%	0.2%
U. S. TREASURY INVESTMENTS	48.5%	47.4%	2.5%
U. S. AGENCY INVESTMENTS	16.2%	16.2%	0.0%
MUNICIPAL BONDS	2.5%	3.6%	-30.6%
COMMERCIAL PAPER	1.1%	2.3%	-49.9%
ASSET BACKED SEC/COLLATERALIZED MORTGAGE OBLIG	17.3%	17.7%	-1.8%
CERTIFICATES OF DEPOSIT	0.0%	0.0%	N/A
TOTAL INVESTMENTS	100.0%	100.0%	0.3%

Note 1 - Investments are carried at amortized cost.

DU PAGE WATER COMMISSION
 INVESTMENTS
 (Unaudited)
 July 31, 2019

FUND SOURCE	COUPON RATE	PURCHASE DATE	MATURITY DATE		YIELD TO MATURITY (COST)	PAR VALUE	PURCHASE PRICE	AMORTIZED DISCOUNT (PREMIUM)	AMORTIZED COST	-ACCRUED INTEREST 07/31/19
<u>Water Fund Oper. & Maint. Acct. (01-121103)</u>										
BMO Harris - Money Market	2.470%	07/31/19	08/01/19	1	2.470%	\$ 12,544,382.23	\$ 12,544,382.23	0.00	\$ 12,544,382.23	-
<u>Water Fund General Account (01-121700)</u>										
IIT - Money Market	2.330%	07/31/19	08/01/19	1	2.330%	8,251,938.97	8,251,938.97	0.00	8,251,938.97	-
FNMA Notes	0.875%	08/31/16	08/28/19	28	1.050%	1,675,000.00	1,672,387.00	2,546.55	1,674,933.55	7,118.75
MUFG Bank LTD/ NY Commercial Paper	0.000%	04/25/19	08/23/19	23	2.590%	1,750,000.00	1,735,008.33	12,243.19	1,747,251.52	-
			Weighted Avg Maturity	6	2.185%	\$ 11,676,938.97	\$ 11,659,334.30	14,789.74	\$ 11,674,124.04	\$ 7,118.75
<u>Sales Tax Funds (01-123000)</u>										
IIT - Money Market	2.330%	07/31/19	08/01/19	1	2.330%	286.72	286.72	0.00	286.72	-
			Weighted Avg Maturity	1	2.330%	\$ 286.72	\$ 286.72	0.00	\$ 286.72	\$ -

DU PAGE WATER COMMISSION
 INVESTMENTS
 (Unaudited)
 July 31, 2019

FUND SOURCE	COUPON RATE	PURCHASE DATE	MATURITY DATE		YIELD TO MATURITY (COST)	PAR VALUE	PURCHASE PRICE	AMORTIZED DISCOUNT (PREMIUM)	AMORTIZED COST	ACCRUED INTEREST 07/31/19
Water Fund Operating Reserve (01-121800)										
IIIT - Money Market	2.330%	07/31/19	08/01/19	1	2.330%	734,350.63	734,350.63	0.00	734,350.63	-
US Treasury Notes	2.125%	12/30/15	08/31/20	397	1.740%	375,000.00	381,489.26	(4,938.17)	376,551.09	3,334.75
US Treasury Notes	2.625%	05/03/16	11/15/20	473	1.210%	250,000.00	265,507.81	(11,007.72)	254,500.09	1,390.96
US Treasury Notes	2.000%	03/24/16	11/30/20	488	1.380%	1,000,000.00	1,028,007.81	(19,870.18)	1,008,137.63	3,387.98
US Treasury Notes	2.375%	03/31/16	12/31/20	519	1.280%	775,000.00	813,931.64	(27,102.02)	786,829.62	1,600.54
US Treasury Notes	2.000%	07/06/16	02/28/21	578	0.920%	775,000.00	812,902.34	(24,819.93)	788,082.41	6,486.41
US Treasury Notes	1.250%	06/27/16	03/31/21	609	0.980%	1,265,000.00	1,281,108.99	(10,385.12)	1,270,723.87	5,314.04
US Treasury Notes	2.000%	01/05/17	05/31/21	670	1.870%	1,300,000.00	1,307,007.81	(4,019.77)	1,302,988.04	4,404.37
US Treasury Notes	2.000%	09/01/16	05/31/21	670	1.220%	1,950,000.00	2,020,078.13	(42,551.89)	1,977,526.24	6,606.56
US Treasury Notes	2.000%	12/05/16	08/31/21	762	1.930%	2,100,000.00	2,106,234.37	(3,412.60)	2,102,821.77	17,576.09
US Treasury Notes	1.250%	03/13/17	10/31/21	823	2.110%	205,000.00	197,232.42	3,900.11	201,132.53	647.59
US Treasury Notes	2.000%	08/30/17	10/31/21	823	1.640%	2,000,000.00	2,028,515.63	(12,884.59)	2,015,631.04	10,108.70
US Treasury Notes	1.750%	04/03/17	11/30/21	853	1.860%	850,000.00	845,882.82	2,014.01	847,896.83	2,519.81
US Treasury Notes	1.750%	10/03/17	11/30/21	853	1.860%	1,500,000.00	1,495,195.31	2,069.71	1,497,265.02	4,446.72
US Treasury Notes	2.125%	06/28/17	12/31/21	884	1.720%	4,000,000.00	4,070,781.25	(32,199.69)	4,038,581.56	7,391.30
US Treasury Notes	1.750%	08/01/17	02/28/22	943	1.780%	1,800,000.00	1,797,539.06	1,054.42	1,798,593.48	13,182.07
US Treasury Notes	1.875%	01/02/18	09/30/22	1,004	1.930%	1,050,000.00	1,040,935.55	3,949.54	1,044,885.09	4,643.68
US Treasury Notes	1.625%	07/01/19	11/15/22	1,157	2.240%	275,000.00	270,552.73	1,427.76	271,980.49	1,732.84
US Treasury Notes	1.625%	07/01/19	11/15/22	1,203	1.740%	1,000,000.00	996,250.00	89.72	996,339.72	3,444.29
US Treasury Notes	2.125%	09/05/18	12/31/22	1,249	2.770%	1,175,000.00	1,144,248.05	6,150.14	1,150,398.19	2,171.20
US Treasury Notes	1.750%	06/04/18	01/31/23	1,280	2.760%	3,600,000.00	3,442,640.63	37,243.57	3,479,884.20	171.20
US Treasury Notes	1.375%	12/10/18	06/30/23	1,430	2.710%	1,000,000.00	943,085.94	7,579.81	950,665.75	1,195.65
US Treasury Notes	2.250%	01/29/19	12/31/23	1,614	2.560%	1,270,000.00	1,251,991.80	1,748.94	1,253,740.74	2,484.78
US Treasury Notes	2.750%	02/26/19	02/15/24	1,680	2.480%	1,330,000.00	1,347,767.97	(1,442.99)	1,346,324.98	16,873.00
US Treasury Notes	2.375%	03/01/19	02/29/24	1,674	2.580%	550,000.00	545,208.98	367.96	545,576.94	5,466.37
US Treasury Notes	2.125%	04/01/19	03/31/24	1,705	2.300%	1,050,000.00	1,041,140.63	552.97	1,041,693.60	7,498.46
US Treasury Notes	2.000%	05/28/19	04/30/24	1,735	2.100%	1,420,000.00	1,413,121.88	238.94	1,413,360.82	7,177.17
US Treasury Notes	2.500%	06/03/19	05/15/24	1,750	1.900%	1,200,000.00	1,233,843.75	(1,013.71)	1,232,830.04	6,358.70
African Development Bank Note	1.125%	09/14/16	09/20/19	51	1.160%	505,000.00	504,464.70	510.66	504,975.36	2,067.34
Intl Bank of Recons and Dev Notes (World Bank)	1.625%	03/14/16	03/09/21	587	1.730%	925,000.00	920,597.00	2,944.45	923,541.45	5,928.99
Intl Bank of Recons and Dev Notes Global Notes	2.750%	07/18/18	07/23/21	723	2.830%	790,000.00	788,151.40	609.79	788,761.19	482.78
CT ST Taxable GO Bonds	1.300%	08/03/16	08/15/19	15	1.230%	710,000.00	711,533.60	(1,513.38)	710,020.22	4,256.06
MS ST Taxable GO Bonds	1.679%	02/18/15	10/01/19	52	1.580%	310,000.00	310,000.00	0.00	310,000.00	1,734.97
NY Trans Fin Auth, NY Txb Rev Bonds	2.750%	04/23/15	02/01/20	185	1.880%	375,000.00	389,816.25	(13,201.75)	376,614.50	5,156.25
NY ST Dorm Auth Pits Txb Rev Bonds	3.100%	12/12/18	03/15/21	593	3.100%	610,000.00	610,000.00	0.00	610,000.00	7,143.78
NY Trans Fin Auth, NY Txb Rev Bonds	1.500%	07/14/16	05/01/21	640	1.500%	600,000.00	600,000.00	0.00	600,000.00	2,250.00

DU PAGE WATER COMMISSION
 INVESTMENTS
 (Unaudited)
 July 31, 2019

FUND SOURCE	COUPON RATE	PURCHASE DATE	MATURITY DATE	YIELD TO MATURITY (COST)	PAR VALUE	PURCHASE PRICE	AMORTIZED DISCOUNT (PREMIUM)	AMORTIZED COST	ACCRUED INTEREST 07/31/19
Water Fund Operating Reserve (01-121800) Continued...									
FHMS K731 A1	3.481%	04/13/18	04/25/24	1.730 2.740%	338,863.21	345,640.49	(1,532.19)	344,108.30	982.99
FNMA Pool #ALJ3174	3.500%	02/17/16	10/01/26	2,619 2.270%	205,643.60	218,708.83	(2,823.27)	215,785.56	600.38
FNMA Pool #AT3221	3.500%	06/17/16	03/01/27	2,770 2.270%	223,056.18	237,136.60	(2,689.16)	234,447.44	650.58
FN AL2092	3.000%	03/06/18	07/25/27	2,916 2.900%	415,514.78	416,034.19	(130.90)	415,903.29	1,038.79
FN AP4718	2.500%	07/20/18	08/25/27	2,947 2.960%	286,936.89	281,242.99	457.10	281,700.09	597.79
Fannie Mae Pool	3.500%	04/05/18	02/01/28	3,107 2.770%	575,027.82	588,145.65	(2,458.59)	585,687.06	1,677.16
Fannie Mae Pool	3.500%	04/05/18	03/01/28	3,136 2.780%	115,772.75	118,413.81	(503.12)	117,910.69	337.67
FN CA1940	4.000%	07/11/18	06/01/28	3,228 3.080%	430,555.65	443,337.76	(1,990.98)	441,346.78	1,435.19
FNMA Pool #AU1266	3.000%	10/31/17	07/25/28	3,282 2.240%	467,207.28	479,106.45	(1,203.27)	477,903.18	1,168.02
Fannie Mae Pool	4.000%	03/18/19	03/25/29	3,525 3.050%	301,091.61	310,359.59	(527.26)	309,832.33	1,003.64
FNMA Pool #AS4197	3.500%	07/16/15	01/01/30	3,807 2.620%	193,906.14	205,298.14	(2,578.85)	202,719.29	565.56
FHLMC Pool #U49048	3.000%	03/17/16	08/01/30	4,019 2.350%	305,780.73	319,206.40	(2,384.23)	316,822.17	764.45
FNMA Pool #AL7738	3.500%	02/17/16	11/01/30	4,111 2.550%	306,074.93	325,921.96	(4,195.92)	321,726.04	892.72
FG G16720	3.500%	01/25/19	11/15/31	4,490 3.110%	340,302.18	345,778.92	(307.37)	345,471.55	992.55
FG G16635	3.000%	04/18/19	02/15/32	4,582 2.790%	551,282.36	555,653.86	(116.75)	555,537.11	1,378.21
Fannie Mae Pool	3.500%	02/13/18	01/25/33	4,927 2.980%	505,581.60	517,273.17	(1,697.73)	515,575.44	1,474.61
Freddie Mac Pool	4.000%	06/07/18	02/15/33	4,948 3.260%	244,180.43	251,544.00	(869.70)	250,674.30	813.93
FN CA1455	4.000%	12/20/18	03/25/33	4,986 3.290%	521,696.14	535,268.39	(827.90)	534,440.49	1,738.99
FN CA2261	4.000%	02/05/19	08/01/33	5,115 3.130%	296,461.04	306,096.03	(503.42)	305,592.61	988.20
Fannie Mae Pool	4.000%	03/01/19	02/25/34	5,323 3.240%	632,058.57	650,329.02	(955.39)	649,373.63	2,106.86
FN BM5830	3.500%	06/05/19	04/25/34	5,382 2.540%	642,555.31	666,651.13	(360.45)	666,290.68	1,874.12
FHLMC Multifamily Structured Pool	4.251%	06/12/18	01/25/20	178 1.570%	433,910.86	442,724.67	(6,358.10)	436,366.57	1,537.13
Fannie Mae Series 2016-M1 ASQ2	2.132%	01/29/16	02/01/21	551 1.680%	480,683.27	485,481.63	(3,919.35)	481,562.28	854.01
FHMS KJ23 A1	3.174%	12/07/18	03/01/22	944 3.050%	751,745.28	751,739.27	0.00	751,739.27	1,988.37
FHLMC Multifamily Structured Pool	2.396%	03/28/19	06/25/22	1,060 2.440%	600,000.00	598,640.63	38.68	598,679.31	1,198.00
FHLMC Multifamily Structured Pool	2.716%	04/02/19	06/25/22	1,060 2.460%	650,000.00	651,625.00	(256.01)	651,368.99	1,471.17
FHLMC Multifamily Structured Pool	2.682%	06/13/19	10/25/22	1,182 1.700%	650,000.00	659,750.00	(231.56)	659,518.44	1,452.75
FHLMC Multifamily Structured Pool	2.510%	06/12/19	11/25/22	1,213 1.920%	650,000.00	655,687.50	(149.11)	655,538.39	1,359.58
FHLMC Series K032 A1	3.016%	06/13/18	02/01/23	1,281 2.880%	187,894.34	188,342.06	(221.79)	188,120.27	472.24
FHLMC Multifamily Structured Pool	2.669%	06/13/18	02/25/23	1,305 2.810%	213,083.85	211,993.47	157.16	212,150.63	473.93
FHMS J22F A1	3.454%	11/07/18	05/25/23	1,394 3.280%	317,589.06	317,580.50	(0.01)	317,580.49	914.13
FHMS KP05 A1	3.203%	12/07/18	07/01/23	1,431 3.110%	263,686.39	263,685.59	0.01	263,685.60	703.82
FHLMC Multifamily Structured Pool	2.741%	10/31/17	10/25/23	1,547 2.010%	631,999.66	644,638.40	(3,791.38)	640,847.02	1,443.59
FHLMC Multifamily Structured Pool	2.951%	12/15/17	02/25/24	1,670 2.240%	622,819.57	635,254.19	(3,340.18)	631,914.01	1,531.62
FHMS K732 A1	3.627%	06/20/18	09/25/24	1,883 2.900%	340,117.39	346,914.99	(1,205.66)	345,709.33	1,028.00
FNA 2017-M15 AV1	2.723%	11/30/17	11/25/24	1,944 2.230%	66,121.14	66,920.01	(219.18)	66,700.83	145.19
FHMS K047 A1	2.827%	06/18/19	12/25/24	1,974 2.140%	655,114.73	666,374.53	(127.76)	666,246.77	1,543.34
FHLMC Multifamily Structured Pool	3.139%	04/11/19	06/25/25	2,156 2.420%	687,538.33	701,288.40	(572.30)	700,716.10	1,798.49
FHS 287 150	1.500%	12/21/17	10/15/27	2,998 2.480%	466,751.04	452,748.50	1,133.94	453,882.44	583.44
Freddie Mac	3.000%	05/03/19	04/15/34	5,372 2.860%	632,828.30	635,943.00	(111.44)	635,831.56	1,582.07
FHLMC Agency	1.375%	04/19/17	04/20/20	264 1.490%	1,075,000.00	1,071,323.50	2,780.39	1,074,103.89	4,146.96
FHLB Notes	1.375%	09/08/17	09/28/20	425 1.480%	600,000.00	598,074.00	1,185.29	599,259.29	2,818.75
FHLB Global Note	1.125%	08/02/16	07/14/21	714 1.210%	1,000,000.00	996,160.00	2,297.69	998,457.69	531.25
FHLB Global Note	1.125%	07/14/16	07/14/21	714 1.250%	1,525,000.00	1,515,726.48	5,581.05	1,521,307.53	810.16
Federal Home Loan Banks Notes	3.000%	09/13/18	09/20/21	782 3.000%	1,335,000.00	1,335,000.00	0.00	1,335,000.00	14,573.75
Fannie Mae Notes	1.875%	04/06/17	04/05/22	979 1.970%	1,120,000.00	1,114,971.20	2,266.88	1,117,238.08	6,766.67
FHLB (Callable) Notes	2.700%	05/02/19	04/29/22	1,003 2.700%	320,000.00	320,000.00	0.00	320,000.00	2,208.00
Fannie Mae Notes	2.500%	02/07/19	02/05/24	1,650 2.580%	930,000.00	926,540.40	313.11	926,853.51	11,172.92
FHLB Bonds	2.500%	02/14/19	02/13/24	1,658 2.580%	1,020,000.00	1,016,389.20	313.75	1,016,702.95	11,758.33
Weighted Avg Maturity			1.413	2.116%	\$ 66,750,983.04	\$ 67,079,780.64	(170,646.24)	\$ 66,909,134.40	\$ 276,585.47

DU PAGE WATER COMMISSION
INVESTMENTS
(Unaudited)
July 31, 2019

FUND SOURCE	COUPON RATE	PURCHASE DATE	MATURITY DATE		YIELD TO MATURITY (COST)	PAR VALUE	PURCHASE PRICE	AMORTIZED DISCOUNT (PREMIUM)	AMORTIZED COST	ACCRUED INTEREST 07/31/19
Water Fund L-T Water Capital Reserve (01-121900)										
HIT - Money Market (PFM Asset Management)										
	2.330%	07/31/19	08/01/19	1	2.330%	76,283.29	76,283.29	0.00	76,283.29	-
US Treasury Notes	2.500%	06/04/18	05/31/20	305	2.510%	85,000.00	84,990.04	5.81	84,995.85	359.97
US Treasury Notes	1.750%	02/03/16	10/31/20	458	1.350%	250,000.00	254,628.91	(3,381.87)	251,247.04	1,105.64
US Treasury Notes	2.000%	03/28/16	11/30/20	488	1.380%	265,000.00	272,442.77	(5,275.52)	267,167.25	897.81
US Treasury Notes	1.625%	11/14/16	11/30/20	488	1.400%	320,000.00	322,800.00	(1,861.17)	320,938.83	880.87
US Treasury Notes	2.000%	03/28/16	10/31/21	823	1.520%	275,000.00	282,014.65	(4,123.26)	277,891.39	1,389.95
US Treasury Notes	1.875%	01/12/15	11/30/21	853	1.780%	260,000.00	261,675.78	(1,084.74)	260,591.04	825.82
US Treasury Notes	1.500%	12/30/15	01/31/22	915	2.040%	75,000.00	72,697.27	1,323.66	74,020.93	3.06
US Treasury Notes	1.500%	09/03/15	01/31/22	915	1.870%	350,000.00	342,234.38	4,629.30	346,863.68	14.27
US Treasury Notes	1.875%	05/01/19	04/30/22	1,004	2.230%	500,000.00	494,863.28	412.62	495,275.90	2,369.23
US Treasury Notes	1.625%	02/26/15	08/15/22	1,111	1.820%	175,000.00	172,662.11	1,348.77	174,010.88	1,311.90
US Treasury Notes	1.625%	12/04/15	11/15/22	1,203	1.930%	200,000.00	196,109.38	1,985.46	198,094.84	688.86
US Treasury Notes	1.500%	02/01/17	03/31/23	1,339	2.210%	425,000.00	407,800.78	6,688.89	414,489.67	2,142.42
US Treasury Notes	1.750%	04/24/15	05/15/23	1,384	1.790%	195,000.00	194,390.62	312.42	194,703.04	723.30
US Treasury Notes	1.375%	08/31/17	06/30/23	1,430	1.850%	175,000.00	170,378.91	1,466.80	171,845.71	209.24
US Treasury Notes	1.375%	09/01/16	08/31/23	1,492	1.470%	125,000.00	124,208.99	319.66	124,528.65	719.26
US Treasury Notes	1.375%	01/03/17	08/31/23	1,492	2.240%	200,000.00	189,320.31	3,939.04	193,259.35	1,150.82
US Treasury Notes	2.750%	12/05/16	11/15/23	1,568	2.260%	60,000.00	61,877.34	(683.68)	61,193.66	349.73
US Treasury Notes	2.750%	03/28/16	11/15/23	1,568	1.720%	150,000.00	160,974.61	(4,631.87)	156,342.74	874.32
US Treasury Notes	2.750%	10/09/15	11/15/23	1,568	1.910%	155,000.00	164,766.21	(4,409.60)	160,356.61	903.46
US Treasury Notes	2.750%	05/26/16	11/15/23	1,568	1.650%	275,000.00	286,097.66	(8,650.46)	287,447.20	1,602.92
US Treasury Notes	2.750%	10/05/16	02/15/24	1,680	1.480%	75,000.00	81,738.28	(2,498.62)	79,239.66	961.48
US Treasury Notes	2.750%	05/09/19	04/30/24	1,735	2.220%	500,000.00	500,605.47	(25.42)	500,580.05	2,843.07
US Treasury Notes	2.500%	03/16/17	05/15/24	1,750	2.450%	300,000.00	300,960.94	(297.07)	300,663.87	1,589.67
US Treasury Notes	2.500%	06/03/19	05/15/24	1,750	1.900%	350,000.00	359,871.09	(295.66)	359,575.43	1,854.62
US Treasury Notes	2.000%	06/28/17	05/31/24	1,766	1.970%	285,000.00	285,545.51	(155.92)	285,389.59	965.57
US Treasury Notes	2.375%	03/28/16	08/15/24	1,842	1.810%	200,000.00	208,679.69	(3,305.93)	205,373.76	2,191.30
US Treasury Notes	2.375%	08/02/17	08/15/24	1,842	2.070%	200,000.00	204,039.66	(1,086.31)	202,952.75	2,191.30
US Treasury Notes	2.125%	12/01/17	11/30/24	1,949	2.280%	475,000.00	470,416.99	1,022.55	471,439.54	1,709.87
US Treasury Notes	2.125%	07/01/19	02/15/25	2,026	1.820%	250,000.00	252,412.11	(32.43)	252,379.68	2,306.63
US Treasury Notes	2.125%	05/03/16	05/15/25	2,115	1.760%	150,000.00	154,558.59	(1,552.75)	153,005.84	675.61
US Treasury Notes	2.875%	07/02/18	05/31/25	2,131	2.830%	250,000.00	250,732.42	(102.13)	250,630.29	1,217.55
US Treasury Notes	2.250%	07/06/16	11/15/25	2,299	1.320%	105,000.00	113,613.28	(2,707.06)	110,906.22	500.75
US Treasury Notes	2.250%	06/27/16	11/15/25	2,299	1.450%	115,000.00	123,036.52	(2,528.25)	120,508.27	548.44
US Treasury Notes	1.625%	06/04/18	05/15/26	2,480	2.930%	250,000.00	227,099.61	3,014.21	230,113.82	861.07
US Treasury Notes	1.625%	09/10/18	05/15/26	2,480	2.900%	275,000.00	250,980.47	2,522.04	253,502.51	947.18
US Treasury Notes	1.500%	11/06/18	08/15/26	2,572	3.160%	150,000.00	132,949.22	1,439.27	134,388.49	1,037.98
US Treasury Notes	2.000%	12/04/18	11/15/26	2,664	2.920%	225,000.00	210,445.31	1,079.02	211,524.33	953.80
US Treasury Notes	2.250%	06/04/18	08/15/27	2,937	2.950%	250,000.00	236,035.16	1,562.72	237,597.88	2,594.96
US Treasury Notes	2.250%	05/01/19	11/15/27	3,029	2.440%	250,000.00	246,328.13	97.65	246,425.78	1,192.26
US Treasury Notes	2.750%	01/30/19	02/15/28	3,121	2.710%	250,000.00	250,722.66	(34.05)	250,688.61	3,171.62
US Treasury Notes	3.125%	05/01/19	02/15/28	3,121	2.470%	150,000.00	158,320.31	(192.19)	158,128.12	993.55
US Treasury Notes	2.625%	06/03/19	02/15/29	3,487	2.120%	100,000.00	104,406.25	(62.45)	104,343.80	1,098.51
US Treasury Notes	2.625%	04/01/19	02/15/29	3,487	2.490%	150,000.00	151,769.53	(50.43)	151,719.10	1,647.76
Infl Bank of Recons and Dev Notes (World Bank)	1.625%	03/14/16	03/09/21	587	1.730%	150,000.00	149,286.00	477.48	149,763.48	961.46
Asian Development Bank Note	1.625%	03/16/16	03/16/21	594	1.640%	150,000.00	149,884.50	76.93	149,961.43	914.06
Infl Bank of Recons and Dev Notes Global Notes	2.750%	07/18/18	07/23/21	723	2.830%	250,000.00	249,415.00	192.97	249,607.97	152.78
MS ST Taxable GO Bonds	1.679%	02/18/15	10/01/19	62	1.680%	40,000.00	40,000.00	0.00	40,000.00	223.87
NY Trans Fin Auth, NY Txbi Rev Bonds	2.750%	04/23/15	02/01/20	185	1.880%	75,000.00	77,963.25	(2,640.35)	75,322.90	1,031.25
CT ST Taxable GO Bonds	2.294%	03/25/15	03/15/20	228	2.290%	70,000.00	70,000.00	0.00	70,000.00	606.64
UNIV OF CAL Taxable Rev Bonds	2.253%	03/25/15	05/15/20	289	2.250%	50,000.00	50,000.00	0.00	50,000.00	237.82
NY Trans Fin Auth, NY Txbi Rev Bonds	1.500%	07/14/16	05/01/21	640	1.500%	100,000.00	100,000.00	0.00	100,000.00	375.00
NY ST Dorm Auth Pits Txbi Rev Bonds	3.250%	12/12/18	03/15/23	1,323	3.250%	180,000.00	180,000.00	0.00	180,000.00	2,210.00

DU PAGE WATER COMMISSION
INVESTMENTS
(Unaudited)
July 31, 2019

FUND SOURCE	COUPON RATE	PURCHASE DATE	MATURITY DATE	YIELD TO MATURITY (COST)	PAR VALUE	PURCHASE PRICE	AMORTIZED DISCOUNT (PREMIUM)	AMORTIZED COST	ACCRUED INTEREST 07/31/19	
Water Fund L-T Water Capital Reserve (01-121900) Continued...										
FNMA Pool #AJ3174	3.500%	02/17/16	10/01/26	2.619	2.270%	32,970.62	35,031.26	(468.21)	34,563.05	96.16
FNMA Pool #AT3221	3.500%	06/17/16	03/01/27	2,770	2.270%	40,761.52	43,334.58	(491.41)	42,843.17	118.89
FNMA Pool #AU1266	3.000%	10/31/17	07/25/28	3,282	2.240%	107,817.06	110,563.04	(277.70)	110,285.34	269.54
Fannie Mae Pool	4.000%	03/18/19	03/25/29	3,525	3.050%	63,867.90	65,833.84	(111.85)	65,721.99	212.89
FNMA Pool #AS4197	3.500%	07/16/15	01/01/30	3,807	2.620%	47,906.23	50,720.72	(637.12)	50,083.60	139.73
FHLMC Pool #U49048	3.000%	03/17/16	08/01/30	4,019	2.350%	45,867.11	47,880.96	(357.64)	47,523.32	114.67
FNMA Pool #AL7738	3.500%	02/17/16	11/01/30	4,111	2.550%	50,517.24	53,792.98	(692.54)	53,100.44	147.34
FG G16635	3.000%	04/18/19	02/15/32	4,582	2.790%	118,131.93	119,068.68	(25.02)	119,043.66	295.33
FN BM5462	3.000%	06/21/19	11/25/32	4,866	2.450%	161,965.24	165,634.77	(25.55)	165,609.22	404.91
Freddie Mac Pool	4.000%	06/07/18	02/15/33	4,948	3.260%	75,132.40	77,398.10	(267.59)	77,130.51	250.44
FN CA1455	4.000%	12/20/18	03/25/33	4,986	3.290%	116,931.90	119,973.95	(185.56)	119,788.39	389.77
FN CA2261	4.000%	02/05/19	08/01/33	5,115	3.130%	63,527.37	65,592.01	(107.88)	65,484.13	211.76
Fannie Mae Pool	4.000%	03/01/19	02/25/34	5,323	3.240%	129,179.85	132,913.96	(195.27)	132,718.69	430.60
FN BM5830	3.500%	06/05/19	04/25/34	5,382	2.540%	160,638.83	166,662.79	(90.12)	166,572.67	468.53
Fannie Mae Series 2016-M1 ASQ2	2.132%	01/29/16	02/01/21	551	1.680%	90,940.07	91,847.87	(741.50)	91,106.37	161.57
FHMS J22F A1	3.454%	11/07/18	05/25/23	1,394	3.280%	67,254.16	67,252.36	(0.02)	67,252.34	193.58
FHMS KP05 A1	3.203%	12/07/18	07/01/23	1,431	3.110%	55,289.09	55,288.93	(0.01)	55,288.92	147.68
FHLMC Multifamily Structured Pool	2.741%	10/31/17	10/25/23	1,547	2.010%	121,538.40	123,968.92	(729.11)	123,239.81	277.61
FHLMC Multifamily Structured Pool	2.951%	12/15/17	02/25/24	1,670	2.240%	191,636.80	195,462.83	(1,027.74)	194,435.09	471.27
FHMS K732 A1	3.627%	06/20/18	09/25/24	1,883	2.900%	97,176.41	99,118.58	(344.47)	98,774.11	293.72
FHMS K047 A1	2.827%	06/18/19	12/25/24	1,974	2.140%	167,678.17	170,560.15	(32.70)	170,527.45	395.02
FHLMC Multifamily Structured Pool	3.139%	04/11/19	06/25/25	2,156	2.420%	149,464.85	152,453.99	(124.41)	152,329.58	390.98
Freddie Mac	3.000%	05/03/19	04/15/34	5,372	2.860%	116,829.84	117,404.86	(20.57)	117,384.29	292.07
FNMA Notes	1.000%	10/19/16	08/28/19	28	1.040%	1,385,000.00	1,383,476.50	1,483.11	1,384,959.61	5,886.25
FHLB Global Note	1.125%	07/13/16	07/14/21	714	1.230%	250,000.00	248,767.50	742.18	249,509.68	132.81
Federal Home Loan Banks Notes	3.000%	09/13/18	09/20/21	782	3.000%	285,000.00	285,000.00	0.00	285,000.00	3,111.25
Fannie Mae Notes	1.875%	04/06/17	04/05/22	979	1.970%	500,000.00	497,755.00	1,012.00	498,767.00	3,020.83
FHLB (Callable) Notes	2.700%	05/02/19	04/29/22	1,003	2.700%	135,000.00	135,000.00	0.00	135,000.00	931.50
Fannie Mae Notes	2.500%	02/07/19	02/05/24	1,650	2.580%	195,000.00	194,274.60	65.65	194,340.25	2,342.71
FHLB Bonds	2.500%	02/14/19	02/13/24	1,658	2.580%	215,000.00	214,238.90	66.13	214,305.03	2,478.47
FNMA Notes	2.125%	04/26/16	04/24/26	2,459	2.210%	210,000.00	208,357.80	497.13	208,854.93	1,202.40
FNMA Notes	2.125%	06/04/18	04/24/26	2,459	3.070%	250,000.00	233,645.00	2,163.14	235,808.14	1,431.42
FNMA Benchmark Note	1.875%	12/20/18	09/24/26	2,612	2.970%	500,000.00	462,350.00	2,674.82	465,024.82	3,307.29
		Weighted Avg Maturity	1.715		2.144%	\$ 17,159,306.28	\$ 17,135,658.07	(16,001.75)	\$ 17,119,656.32	\$ 89,299.17
Capital Reserve (01-122000)										
IIIT - Money Market (PFM Asset Management)	2.330%	07/31/19	08/01/19	1	2.330%	511,643.65	511,643.65	0.00	511,643.65	-
US Treasury Notes	1.375%	05/08/17	05/31/20	305	1.570%	500,000.00	497,128.90	2,079.08	499,207.98	1,164.62
US Treasury Notes	1.625%	06/28/17	06/30/20	335	1.500%	3,300,000.00	3,311,988.28	(8,289.97)	3,303,698.31	4,663.04
US Treasury Notes	1.375%	08/30/17	08/31/20	397	1.450%	2,000,000.00	1,995,703.13	2,726.69	1,998,429.82	11,508.15
US Treasury Notes	1.375%	10/05/17	09/30/20	427	1.640%	1,620,000.00	1,607,533.59	7,537.40	1,615,070.99	7,485.86
US Treasury Notes	1.375%	11/01/17	10/31/20	458	1.770%	1,200,000.00	1,186,406.25	7,847.20	1,194,253.45	4,169.84
US Treasury Notes	2.000%	03/24/16	11/30/20	488	1.380%	1,000,000.00	1,028,007.82	(19,870.19)	1,008,137.63	3,387.98
US Treasury Notes	1.750%	12/01/17	12/31/20	519	1.910%	2,500,000.00	2,488,281.25	6,248.33	2,494,529.58	3,804.35
US Treasury Notes	1.375%	01/02/18	01/31/21	550	2.050%	750,000.00	735,029.30	7,561.83	742,591.13	28.02
US Treasury Notes	2.375%	03/11/19	04/15/21	624	2.470%	500,000.00	498,984.38	190.60	499,174.98	3,504.10
US Treasury Notes	2.625%	06/11/18	05/15/21	654	2.660%	500,000.00	499,531.25	181.40	499,712.65	2,781.93
US Treasury Notes	2.625%	07/02/18	05/15/21	654	2.640%	1,475,000.00	1,474,308.59	269.59	1,474,578.18	8,206.69
US Treasury Notes	1.625%	07/01/19	06/30/21	700	1.770%	600,000.00	598,335.94	67.14	598,403.08	847.83
US Treasury Notes	1.125%	09/05/18	09/30/21	792	2.720%	535,000.00	510,005.47	7,145.03	517,150.50	2,022.69
US Treasury Notes	2.500%	01/29/19	01/15/22	899	2.550%	1,900,000.00	1,897,550.78	413.47	1,897,964.25	2,194.29
US Treasury Notes	1.500%	01/07/19	01/31/22	915	2.490%	2,500,000.00	2,427,343.75	12,905.95	2,440,249.70	101.90
US Treasury Notes	1.750%	03/07/19	02/28/22	943	2.460%	2,250,000.00	2,204,296.88	5,907.06	2,210,203.94	16,477.58
US Treasury Notes	2.250%	05/28/19	04/15/22	989	2.090%	820,000.00	823,683.59	(217.62)	823,465.97	5,444.26
US Treasury Notes	1.875%	05/01/19	04/30/22	1,004	2.230%	1,700,000.00	1,682,535.16	1,402.88	1,683,938.04	8,055.37
US Treasury Notes	1.875%	05/09/19	05/31/22	1,035	2.220%	2,000,000.00	1,979,843.75	1,464.47	1,981,308.22	6,352.46
US Treasury Notes	1.875%	06/03/19	05/31/22	1,035	1.850%	2,500,000.00	2,501,757.81	(88.81)	2,501,669.00	7,940.57
African Development Bank Note	1.125%	09/14/16	09/20/19	51	1.160%	235,000.00	234,750.90	237.63	234,988.53	962.03
Intl Bank of Recons and Dev Notes Global Notes	2.750%	07/18/18	07/23/21	723	2.830%	420,000.00	419,017.20	324.19	419,341.39	256.67

DU PAGE WATER COMMISSION
 INVESTMENTS
 (Unaudited)
 July 31, 2019

FUND SOURCE	COUPON RATE	PURCHASE DATE	MATURITY DATE		YIELD TO MATURITY (COST)	PAR VALUE	PURCHASE PRICE	AMORTIZED DISCOUNT (PREMIUM)	AMORTIZED COST	ACCRUED INTEREST 07/31/19
Capital Reserve (01-122000) Continued...										
CT ST Taxable GO Bonds	1.300%	06/03/16	08/15/19	15	1.230%	330,000.00	330,712.80	(703.40)	330,009.40	1,978.17
NY ST Dorm Auth Pits Txbi Rev Bonds	3.100%	12/12/18	03/15/21	593	3.100%	355,000.00	355,000.00	0.00	355,000.00	4,157.44
FN AB8565	2.000%	04/09/18	03/25/23	1,333	2.520%	180,895.35	178,747.22	389.79	179,137.01	301.49
Fannie Mae Pool	3.500%	04/17/18	06/25/26	2,521	2.820%	368,931.13	375,618.00	(783.49)	374,824.51	1,076.05
Fannie Mae Pool	3.500%	04/17/18	08/25/26	2,582	2.830%	345,611.37	351,875.56	(722.14)	351,153.42	1,008.03
FN AL2092	3.000%	03/06/18	07/25/27	2,916	2.900%	316,650.90	317,046.74	(99.77)	316,946.97	791.63
Fannie Mae Pool	3.500%	04/05/18	02/25/28	3,131	2.770%	479,169.87	490,121.39	(2,048.82)	488,072.57	1,397.64
Fannie Mae Pool	3.500%	04/05/18	03/25/28	3,160	2.780%	270,136.44	276,298.93	(1,173.96)	275,124.97	787.90
Fannie Mae Pool	3.500%	04/05/18	04/25/28	3,191	2.820%	340,202.81	347,644.75	(1,445.09)	346,199.66	992.26
FN CA1940	4.000%	07/11/18	06/01/28	3,228	3.080%	311,640.29	320,892.11	(1,441.10)	319,451.01	1,038.80
Fannie Mae Pool	4.000%	03/18/19	03/25/29	3,525	3.050%	177,917.77	183,394.30	(311.56)	183,082.74	593.06
Fannie Mae Pool	4.000%	03/01/19	02/25/34	5,323	3.240%	369,085.30	379,754.17	(557.89)	379,196.28	1,230.28
Freddie Mac Series 4459 NB	4.500%	06/11/15	01/01/20	154	0.770%	47.72	50.03	(2.13)	47.90	0.18
FHMS K006 A2	4.251%	06/12/18	01/25/20	178	1.570%	314,068.82	320,448.34	(4,802.05)	315,846.29	1,112.59
FNMA Series 2015-M12 FA	0.540%	09/30/15	04/25/20	269	0.540%	5,281.33	5,279.43	1.90	5,281.33	12.24
FHMS KJ23 A1	3.174%	12/07/18	03/01/22	944	3.050%	390,517.04	390,513.91	0.01	390,513.92	1,032.92
FHLMC Multifamily Structured Pool	2.396%	04/02/19	06/25/22	1,060	2.440%	350,000.00	349,207.03	22.57	349,229.60	698.83
FHLMC Multifamily Structured Pool	2.396%	04/02/19	06/25/22	1,060	2.440%	350,000.00	349,207.03	22.57	349,229.60	698.83
FHLMC Multifamily Structured Pool	2.716%	04/02/19	06/25/22	1,060	2.460%	500,000.00	501,250.00	(196.93)	501,053.07	1,131.67
FHLMC Multifamily Structured Pool	2.682%	06/13/19	10/25/22	1,182	1.700%	450,000.00	456,750.00	(160.31)	456,589.69	1,005.75
FHLMC Multifamily Structured Pool	2.510%	06/12/19	11/25/22	1,213	1.920%	450,000.00	453,937.50	(103.23)	453,834.27	941.25
FHLMC Series K032 A1	3.016%	06/13/18	02/01/23	1,281	2.880%	136,223.40	136,547.99	(160.79)	136,387.20	342.37
FHLMC Multifamily Structured Pool	2.669%	06/13/18	02/25/23	1,305	2.810%	156,603.81	155,802.44	115.50	155,917.94	348.31
FHMS J22F A1	3.454%	11/07/18	05/25/23	1,394	3.280%	194,289.77	194,284.54	(0.02)	194,284.52	559.23
FHMS K047 A1	2.827%	06/18/19	12/25/24	1,974	2.140%	448,441.63	456,149.23	(87.45)	456,061.78	1,056.45
FNMA Notes	1.500%	07/28/17	07/30/20	365	1.600%	2,500,000.00	2,492,425.00	5,014.20	2,497,439.20	104.17
FHLB Notes	1.375%	09/08/17	09/29/20	425	1.480%	1,300,000.00	1,295,827.00	2,568.14	1,298,395.14	6,107.29
Fannie Mae Notes	2.875%	10/30/18	10/30/20	457	2.910%	1,500,000.00	1,499,130.00	320.70	1,499,450.70	10,901.04
Federal Home Loan Banks Notes	3.000%	09/13/18	09/20/21	782	3.000%	910,000.00	910,000.00	0.00	910,000.00	9,934.17
FHLB (Callable) Notes	2.700%	05/02/19	04/29/22	1,003	2.700%	905,000.00	905,000.00	0.00	905,000.00	6,244.50
Weighted Avg Maturity			866		2.144%	\$ 46,022,378.40	\$ 45,892,583.06	29,888.60	\$ 45,922,471.66	\$ 158,944.77
TOTAL ALL FUNDS					2.162%	\$154,154,275.64	\$154,312,025.02	(141,969.65)	\$ 154,170,055.37	\$ 531,948.16
Less: Net Unsettled Trades										
									\$ 154,170,055.37	
July 31, 2019					90 DAY US TREASURY YIELD		2.08%			
					3 month US Treasury Bill Index		2.07%			
					0-3 Year US Treasury Index		1.98%			
					1-3 Year US Treasury Index		1.95%			
					1-5 Year US Treasury Index		1.91%			
					1-10 Year US Treasury Index		1.92%			

DUPAGE WATER COMMISSION
ELMHURST, ILLINOIS
TREASURER'S REPORT
STATEMENT OF CASH FLOWS
For the Period from May 1, 2019 to July 31, 2019

CASH FLOWS FROM OPERATING ACTIVITIES

Cash received from customers	\$ 30,350,564
Cash payments to suppliers	(27,224,031)
Cash payments to employees	(952,493)
Net cash from operating activities	2,174,040

CASH FLOWS FROM NONCAPITAL
FINANCING ACTIVITIES

Cash received from sales taxes	0
Cash received/paid from long term loans	(371,827)
Cash payments for net pension activity	0
Net cash from noncapital financing activities	(371,827)

CASH FLOWS FROM CAPITAL AND
RELATED FINANCING ACTIVITIES

Interest paid	0
Principal Paid	0
Construction and purchase of capital assets	(164,524)
Net cash from capital and related financing activities	(164,524)

CASH FLOWS FROM INVESTING ACTIVITIES

Investment income	1,011,360
Net cash from investing activities	1,011,360

Net Increase (Decrease) in cash and investments	2,649,049
---	-----------

CASH AND INVESTMENTS, MAY 1, 2019	171,151,957
-----------------------------------	-------------

CASH AND INVESTMENTS, JULY 31, 2019	\$ 173,801,006
-------------------------------------	----------------

July 31, 2019
 TREASURER'S REPORT
 DPWC MONTHLY CASH/OPERATING REPORT

	7/31/2019		
	YEAR END TARGETED Reserve or Monthly Cash Amount-Needed	Amount On Hand	Amount Over - (Under) Target
	A	B	C
TABLE 1			
RESERVE ANALYSIS			
A .Operating Reserve # of days per current fiscal year management budget	\$ 65,791,115 180	\$ 66,909,134 183	\$ 1,118,019
B. Capital Reserve	\$ 44,739,500	\$ 45,034,603	\$ 295,103
C. Long Term Water Capital Reserve	\$ 16,225,000	\$ 17,119,656	\$ 894,656
D. O+M Account (1)	\$ 13,597,447	\$ 32,175,332	\$ 18,577,885
E. Current Construction Obligation and Customer Construction Escrows	\$ 887,868	\$ 887,868	\$ -
TOTAL SUMMARY CASH + RESERVE ANALYSIS	\$ 141,240,931	\$ 162,126,595	\$ 20,885,664

TABLE 2	
OTHER CASH	
F. General Fund	\$ 11,674,124
G. Sales Tax	\$ 287
TOTAL TABLE 2-OTHER CASH	\$ 11,674,411
TOTAL MONTH END FUNDS CASH BALANCE-Table1+2	\$ 173,801,006

Note 1: The O&M Account target varies from month to month. The cash balance should be enough to cover the current months operating cash outflows.

DATE: August 6, 2019

REQUEST FOR BOARD ACTION

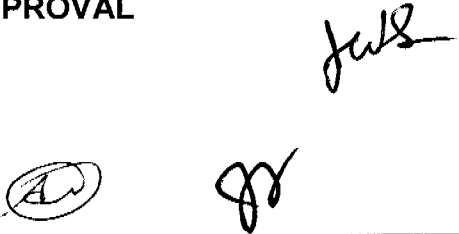
AGENDA SECTION	Administration Committee	ORIGINATING DEPARTMENT	Instrumentation/ Remote Facilities
ITEM	A Resolution Authorizing and Ratifying the Disposal of Certain Personal Property Owned by the DuPage Water Commission Resolution No. R-27-19	APPROVAL 	
<p>Account Number: N/A</p> <p>Resolution No. R-27-19 is a Resolution Authorizing and Ratifying the Disposal of Certain Personal Property Owned by the DuPage Water Commission. This Resolution authorizes the General Manager to dispose of the assets listed on Exhibit A to the Resolution or, if already disposed of, ratifies and confirms their disposal because these assets are or were no longer useful to the Commission.</p> <p>The computer and electronic equipment listed in Exhibit A will be donated to ATEN – Assistive Technology Exchange Network, A Program of United Cerebral Palsy of Greater Chicago, they refurbish and recycle donated computers and distributes them free of charge to children with disabilities.</p> <p style="text-align: center;">Assistive Technology Exchange Network 7550 W. 183rd Street Tinley Park, IL 60477 708-444-8460</p>			
MOTION: To adopt Resolution No. R-27-19			

DUPAGE WATER COMMISSION

RESOLUTION NO. R-27-19

A RESOLUTION AUTHORIZING AND RATIFYING
THE DISPOSAL OF CERTAIN PERSONAL PROPERTY
OWNED BY THE DUPAGE WATER COMMISSION

WHEREAS, the DuPage Water Commission is authorized to sell or otherwise dispose of personal property pursuant to 65 ILCS 5/11-135-6; and

WHEREAS, in the opinion of the Board of Commissioners of the DuPage Water Commission, the personal property described in Exhibit A attached hereto and by this reference incorporated herein and made a part hereof (the "Property") is no longer necessary or useful to or for the best interests of the DuPage Water Commission to retain or, if already disposed of, was not necessary or useful to or for the best interests of the DuPage Water Commission to retain;

NOW, THEREFORE, BE IT RESOLVED by the Board of Commissioners of the DuPage Water Commission as follows:

SECTION ONE: The Board of Commissioners of the DuPage Water Commission hereby finds and determines that the Property is no longer necessary or useful to the DuPage Water Commission and the best interests of the DuPage Water Commission will be served by its disposal or, if already disposed of, was not necessary or useful to the DuPage Water Commission and the best interests of the DuPage Water Commission were served by its disposal.

SECTION TWO: The General Manager is hereby authorized to dispose of the Property in such manner as the General Manager shall determine or, if already disposed

Resolution No. R-27-19

of, the Board of Commissioners of the DuPage Water Commission hereby ratifies and confirms its disposal.

SECTION THREE: This Resolution shall be in full force and effect from and after its adoption.

AYES:

NAYS:

ABSENT:

ADOPTED this _____ day of _____, 2019.

Chairman

ATTEST:

Clerk

EXHIBIT A

OBSOLETE / DEFECTIVE ITEMS

Qty	DWC Inventory # and/or S/N	Description	Date Purchased	Cost
1	FQRTKN1	Dell PowerEdge R710	03/12/10	
1	46WR1P1	Dell PowerVault MD1220	03/08/10	
1	448274	ACE computer	06/21/12	\$715.00
1	448275	ACE computer	06/21/12	\$715.00
1	448277	ACE computer	06/21/12	\$715.00
1	455515	ACE computer	06/21/12	\$715.00
1	2091000689	Premio Q8200 desktop computer	12/30/09	\$775.00
1	2111000127	Premio Q8400 desktop computer	02/07/11	\$750.00
1	2111000128	Premio Q8400 desktop computer	02/07/11	\$750.00
1	2111000129	Premio Q8400 desktop computer	02/07/11	\$750.00
1	2111000131	Premio Q8400 desktop computer	02/07/11	\$750.00
1	2111000132	Premio Q8400 desktop computer	02/07/11	\$750.00
1	3206532425	ACER Travelmate 8472	03/11/14	\$870.00
1	FOC1121X1TK	Cisco Catalyst 2960	02/17/05	685.00
1	FOC1009X2EN	Cisco Catalyst 2950	04/18/06	635.40
1	F3LMQS070548	ASUS VE247 monitor	02/10/15	167.00
1	BD819A85153	Planar PL1910M monitor	01/22/08	\$226.00
1	BD819A84997	Planar PL1910M monitor	01/22/08	\$226.00
1	04004400640	ACER V193 monitor	02/04/11	\$135.00
1	04004400940	ACER V193 monitor	02/04/11	\$135.00

DATE: July 25, 2019

REQUEST FOR BOARD ACTION

AGENDA SECTION	Engineering & Construction Committee	ORIGINATING DEPARTMENT	General Manager's Office
ITEM	An Ordinance Determining the Prevailing Rate of Wages in DuPage County and Cook County Ordinance No. O-5-19	APPROVAL 	
<p>Attached is "An Ordinance Determining the Prevailing Rate of Wages in DuPage County and Cook County." This Ordinance is adopted annually by the Commission. This Ordinance establishes the prevailing rate of wages for various construction trades working on Commission public works construction projects. The prevailing rate of wages included in this Ordinance have been obtained from the Illinois Department of Labor. The Commission includes a copy of its then current prevailing wage ordinance in all of its public works construction specifications.</p> <p>Once adopted by the Commission, a certified copy of this Ordinance will be filed with the Department of Labor of the State of Illinois as required by law. The Commission will also publish a notice of the adoption of the Ordinance in a newspaper of general circulation within the area, within thirty (30) days following its filing with the Secretary of State and the Department of Labor.</p>			
MOTION: To adopt Ordinance No. O-5-19.			

DuPAGE WATER COMMISSION

ORDINANCE NO. O-5-19

**AN ORDINANCE DETERMINING THE
PREVAILING RATE OF WAGES IN
DuPAGE COUNTY AND COOK COUNTY**

WHEREAS, the State of Illinois has enacted "An Act Regulating Wages of Laborers, Mechanics and Other Workers Employed in Any Public Works by the State, County, City or Any Public Body or Any Political Subdivision or By Anyone Under Contract for Public Works," approved June 26, 1941, as amended, being Act 130 (Prevailing Wage Act), of Chapter 820 (Employment), of the Illinois Compiled Statutes, 820 ILCS 130/0.01 et seq. (the "Act"); and

WHEREAS, the Act requires that the DuPage Water Commission investigate and ascertain the prevailing rate of wages as defined in the Act for laborers, mechanics and other workers in the localities of DuPage County and Cook County employed in the construction of public works for the DuPage Water Commission; and

WHEREAS, "locality" is defined in the Act as the County where the physical work upon public works is performed and the public works of the DuPage Water Commission will be performed in both DuPage and Cook County;

NOW, THEREFORE, BE IT ORDAINED by the Board of Commissioners of the DuPage Water Commission as follows:

SECTION ONE: To the extent and as required by the Act, the general prevailing rate of wages in DuPage County for laborers, mechanics and other workers engaged in the construction of public works coming under the jurisdiction of the DuPage Water Commission, which physical work is being performed on public works in DuPage County, is hereby ascertained to be the same as the prevailing rate of wages for construction work

Ordinance No. O-5-19

in the DuPage County area as determined by the Department of Labor of the State of Illinois as of July 2019. A copy of that determination is attached hereto, and by this reference incorporated herein, as Exhibit A. As required by the Act, any and all revisions of the prevailing rate of wages in DuPage County by the Department of Labor of the State of Illinois shall supersede the Department's August determination and shall apply to any and all public works construction in DuPage County undertaken by the Commission.

SECTION TWO: To the extent and as required by the Act, the general prevailing rate of wages in Cook County for laborers, mechanics and other workers engaged in the construction of public works coming under the jurisdiction of the DuPage Water Commission, which physical work is being performed on public works in Cook County, is hereby ascertained to be the same as the prevailing rate of wages for construction work in the Cook County area as determined by the Department of Labor of the State of Illinois as of July 2019. A copy of that determination is attached hereto, and by this reference incorporated herein, as Exhibit B. As required by the Act, any and all revisions of the prevailing rate of wages in Cook County by the Department of Labor of the State of Illinois shall supersede the Department's August determination and shall apply to any and all public works construction in Cook County undertaken by the Commission.

SECTION THREE: The definition of any terms appearing in this Ordinance that are also used in the Act shall be the same as in the Act. Nothing herein contained shall be construed to apply the general prevailing rate of wages for DuPage County and for Cook County as herein ascertained to any work or employment except public works construction of the DuPage Water Commission conducted in DuPage County and Cook County, respectively, to the extent required by the Act.

SECTION FOUR: The Clerk of the DuPage Water Commission shall publicly post or keep available for inspection by any interested party in the main office of the DuPage Water Commission this determination of the prevailing rate of wages for DuPage County and for Cook County.

SECTION FIVE: The General Manager is hereby directed to:

- (a) promptly file, no later than September 12, 2019, a certified copy of this Ordinance with the Department of Labor of the State of Illinois;
- (b) cause to be published in a newspaper of general circulation within the area a notice of the adoption of this Ordinance, within thirty (30) days of its filing with the Secretary of State and the Department of Labor of the State of Illinois, and such publication shall constitute notice that the determination is effective and that this is the determination of this public body;
- (c) mail a copy of this determination to any employer, to any association of employers and to any person or association of employees who have filed their names and addresses, requesting copies of any determination stating the particular rates and the particular class of workers whose wages will be affected by such rate; and
- (d) attach a copy of this determination or of the revised determination of prevailing rate of wages then in effect to all public works construction contract specifications.

Ordinance No. O-5-19

SECTION SIX: This Ordinance shall be in full force and effect from and after its adoption.

AYES:

NAYS:

ABSENT:

ADOPTED this _____ day of _____, 2019.

Chairman

ATTEST:

Clerk

Board/Ordinances/O-5-19.docx

EXHIBIT A

DuPage County Prevailing Wage Rates posted on 7/15/2019

Trade Title	Rg	Type	C	Base	Foreman	Overtime					Pension	Vac	Trng	Other Ins
						M-F	Sa	Su	Hol	H/W				
ASBESTOS ABT-GEN	All	ALL		43.72	44.72	1.5	1.5	2.0	2.0	14.99	13.61	0.00	0.90	
ASBESTOS ABT-MEC	All	BLD		37.88	40.38	1.5	1.5	2.0	2.0	13.42	12.20	0.00	0.72	
BOILERMAKER	All	BLD		50.51	55.05	2.0	2.0	2.0	2.0	6.97	14.65	0.00	1.10	
BRICK MASON	All	BLD		46.88	51.57	1.5	1.5	2.0	2.0	10.85	19.31	0.00	0.95	
CARPENTER	All	ALL		48.55	50.55	1.5	1.5	2.0	2.0	11.79	21.84	0.00	0.73	
CEMENT MASON	All	ALL		46.25	48.25	2.0	1.5	2.0	2.0	14.50	19.04	0.00	1.25	
CERAMIC TILE FINISHER	All	BLD		40.56	40.56	1.5	1.5	2.0	2.0	11.00	12.80	0.00	0.86	
COMMUNICATION TECHNICIAN	All	BLD		34.25	37.05	1.5	1.5	2.0	2.0	12.35	21.78	2.21	0.68	
ELECTRIC PWR EQMT OP	All	ALL		43.71	59.52	1.5	1.5	2.0	2.0	6.00	13.55	0.00	0.77	1.31
ELECTRIC PWR EQMT OP	All	HWY		41.45	56.38	1.5	1.5	2.0	2.0	5.50	12.87	0.00	0.73	
ELECTRIC PWR GRNDMAN	All	ALL		33.69	59.52	1.5	1.5	2.0	2.0	6.00	10.44	0.00	0.59	1.01
ELECTRIC PWR GRNDMAN	All	HWY		32.00	56.38	1.5	1.5	2.0	2.0	5.50	9.92	0.00	0.66	
ELECTRIC PWR LINEMAN	All	ALL		52.44	59.52	1.5	1.5	2.0	2.0	6.00	16.27	0.00	0.93	1.58
ELECTRIC PWR LINEMAN	All	HWY		49.67	56.38	1.5	1.5	2.0	2.0	5.50	15.40	0.00	0.88	
ELECTRIC PWR TRK DRV	All	ALL		34.90	59.52	1.5	1.5	2.0	2.0	6.00	10.83	0.00	0.62	1.05
ELECTRIC PWR TRK DRV	All	HWY		33.14	56.38	1.5	1.5	2.0	2.0	5.50	10.29	0.00	0.59	
ELECTRICIAN	All	BLD		41.00	45.00	1.5	1.5	2.0	2.0	12.35	24.58	5.72	0.75	
ELEVATOR CONSTRUCTOR	All	BLD		56.61	63.69	2.0	2.0	2.0	2.0	15.58	17.51	4.53	0.62	
FENCE ERECTOR	NE	ALL		42.88	44.88	1.5	1.5	2.0	2.0	13.64	14.89	0.00	0.65	
FENCE ERECTOR	W	ALL		47.00	50.76	2.0	2.0	2.0	2.0	12.26	23.65	0.00	0.88	
GLAZIER	All	BLD		44.85	46.35	1.5	2.0	2.0	2.0	14.49	22.29	0.00	0.94	
HEAT/FROST INSULATOR	All	BLD		50.50	53.00	1.5	1.5	2.0	2.0	13.42	13.66	0.00	0.72	
IRON WORKER	E	ALL		47.00	50.76	2.0	2.0	2.0	2.0	12.26	23.65	0.00	0.88	
IRON WORKER	W	ALL		47.00	50.76	2.0	2.0	2.0	2.0	12.26	23.65	0.00	0.88	
LABORER	All	ALL		43.72	44.47	1.5	1.5	2.0	2.0	14.99	13.61	0.00	0.90	
LATHER	All	ALL		48.55	50.55	1.5	1.5	2.0	2.0	11.79	21.84	0.00	0.73	
MACHINIST	All	BLD		48.93	51.43	1.5	1.5	2.0	2.0	7.68	8.95	1.85	1.32	
MARBLE FINISHER	All	ALL		35.15	48.33	1.5	1.5	2.0	2.0	10.85	17.66	0.00	0.52	
MARBLE MASON	All	BLD		46.03	50.63	1.5	1.5	2.0	2.0	10.85	18.78	0.00	0.64	
MATERIAL TESTER I	All	ALL		33.72		1.5	1.5	2.0	2.0	14.99	13.61	0.00	0.90	
MATERIALS TESTER II	All	ALL		38.72		1.5	1.5	2.0	2.0	14.99	13.61	0.00	0.90	

MILLWRIGHT	All	ALL		48.55	50.55	1.5	1.5	2.0	2.0	11.79	21.84	0.00	0.73	
OPERATING ENGINEER	All	BLD	1	51.10	55.10	2.0	2.0	2.0	2.0	20.50	16.85	2.00	1.65	
OPERATING ENGINEER	All	BLD	2	49.80	55.10	2.0	2.0	2.0	2.0	20.50	16.85	2.00	1.65	
OPERATING ENGINEER	All	BLD	3	47.25	55.10	2.0	2.0	2.0	2.0	20.50	16.85	2.00	1.65	
OPERATING ENGINEER	All	BLD	4	45.50	55.10	2.0	2.0	2.0	2.0	20.50	16.85	2.00	1.65	
OPERATING ENGINEER	All	BLD	5	54.85	55.10	2.0	2.0	2.0	2.0	20.50	16.85	2.00	1.65	
OPERATING ENGINEER	All	BLD	6	52.10	55.10	2.0	2.0	2.0	2.0	20.50	16.85	2.00	1.65	
OPERATING ENGINEER	All	BLD	7	54.10	55.10	2.0	2.0	2.0	2.0	20.50	16.85	2.00	1.65	
OPERATING ENGINEER	All	FLT		38.00	38.00	1.5	1.5	2.0	2.0	19.65	15.10	2.00	1.40	
OPERATING ENGINEER	All	HWY	1	49.30	53.30	1.5	1.5	2.0	2.0	20.50	16.85	2.00	1.65	
OPERATING ENGINEER	All	HWY	2	48.75	53.30	1.5	1.5	2.0	2.0	20.50	16.85	2.00	1.65	
OPERATING ENGINEER	All	HWY	3	46.70	53.30	1.5	1.5	2.0	2.0	20.50	16.85	2.00	1.65	
OPERATING ENGINEER	All	HWY	4	45.30	53.30	1.5	1.5	2.0	2.0	20.50	16.85	2.00	1.65	
OPERATING ENGINEER	All	HWY	5	44.10	53.30	1.5	1.5	2.0	2.0	20.50	16.85	2.00	1.65	
OPERATING ENGINEER	All	HWY	6	52.30	53.30	1.5	1.5	2.0	2.0	20.50	16.85	2.00	1.65	
OPERATING ENGINEER	All	HWY	7	50.30	53.30	1.5	1.5	2.0	2.0	20.50	16.85	2.00	1.65	
ORNAMENTAL IRON WORKER	E	ALL		50.05	52.55	2.0	2.0	2.0	2.0	14.14	21.13	0.00	1.25	
ORNAMENTAL IRON WORKER	W	ALL		45.06	48.66	2.0	2.0	2.0	2.0	10.52	20.76	0.00	0.70	
PAINTER	All	ALL		47.30	49.30	1.5	1.5	1.5	2.0	12.43	8.65	0.00	1.45	
PAINTER - SIGNS	All	BLD		39.06	43.86	1.5	1.5	2.0	2.0	2.67	3.32	0.00	0.00	
PILEDRIVER	All	ALL		48.55	50.55	1.5	1.5	2.0	2.0	11.79	21.84	0.00	0.73	
PIPEFITTER	All	BLD		49.60	52.60	1.5	1.5	2.0	2.0	10.75	19.85	0.00	2.67	
PLASTERER	All	BLD		46.75	49.56	1.5	1.5	2.0	2.0	10.85	19.01	0.00	0.95	
PLUMBER	All	BLD		51.00	54.05	1.5	1.5	2.0	2.0	15.37	14.75	0.00	1.35	
ROOFER	All	BLD		44.60	48.60	1.5	1.5	2.0	2.0	10.38	12.74	0.00	0.58	
SHEETMETAL WORKER	All	BLD		48.87	51.31	1.5	1.5	2.0	2.0	10.78	17.51	0.00	0.93	2.31
SPRINKLER FITTER	All	BLD		50.15	52.65	1.5	1.5	2.0	2.0	13.50	16.60	0.00	0.65	
STEEL ERECTOR	E	ALL		47.00	50.76	2.0	2.0	2.0	2.0	12.26	23.65	0.00	0.88	
STEEL ERECTOR	W	ALL		45.06	48.66	2.0	2.0	2.0	2.0	10.52	20.76	0.00	0.70	
STONE MASON	All	BLD		46.88	51.57	1.5	1.5	2.0	2.0	10.85	19.31	0.00	0.95	
TERRAZZO FINISHER	All	BLD		42.54	42.54	1.5	1.5	2.0	2.0	11.00	14.64	0.00	0.88	
TERRAZZO MASON	All	BLD		46.38	49.88	1.5	1.5	2.0	2.0	11.00	16.09	0.00	0.93	
TILE MASON	All	BLD		47.50	51.50	1.5	1.5	2.0	2.0	11.00	16.06	0.00	0.93	
TRAFFIC SAFETY WORKER	All	HWY		37.75	39.35	1.5	1.5	2.0	2.0	9.30	9.87	0.00	0.30	
TRUCK DRIVER	All	ALL	1	37.61	38.16	1.5	1.5	2.0	2.0	9.08	11.36	0.00	0.15	
TRUCK DRIVER	All	ALL	2	37.76	38.16	1.5	1.5	2.0	2.0	9.08	11.36	0.00	0.15	

TRUCK DRIVER	All	ALL	3	37.96	38.16	1.5	1.5	2.0	2.0	9.08	11.36	0.00	0.15
TRUCK DRIVER	All	ALL	4	38.16	38.16	1.5	1.5	2.0	2.0	9.08	11.36	0.00	0.15
TUCKPOINTER	All	BLD		46.50	47.50	1.5	1.5	2.0	2.0	8.34	18.40	0.00	0.93

Legend

Rg Region

Type Trade Type - All,Highway,Building,Floating,Oil & Chip,Rivers

C Class

Base Base Wage Rate

OT M-F Unless otherwise noted, OT pay is required for any hour greater than 8 worked each day, Mon through Fri. The number listed is the multiple of the base wage.

OT Sa Overtime pay required for every hour worked on Saturdays

OT Su Overtime pay required for every hour worked on Sundays

OT Hol Overtime pay required for every hour worked on Holidays

H/W Health/Welfare benefit

Vac Vacation

Trng Training

Other Ins Employer hourly cost for any other type(s) of insurance provided for benefit of worker.

Explanations DUPAGE COUNTY

IRON WORKERS AND FENCE ERECTOR (WEST) - West of Route 53.

The following list is considered as those days for which holiday rates of wages for work performed apply: New Years Day, Memorial Day, Fourth of July, Labor Day, Thanksgiving Day, Christmas Day and Veterans Day in some classifications/counties. Generally, any of these holidays which fall on a Sunday is celebrated on the following Monday. This then makes work performed on that Monday payable at the appropriate overtime rate for holiday pay. Common practice in a given local may alter certain days of celebration. If in doubt, please check with IDOL.

EXPLANATION OF CLASSES

ASBESTOS - GENERAL - removal of asbestos material/mold and hazardous materials from any place in a building, including mechanical systems where those mechanical systems are to be removed. This includes the removal of asbestos materials/mold and hazardous materials from ductwork or pipes in a building when the building is to be demolished at the time or at some close future date.

ASBESTOS - MECHANICAL - removal of asbestos material from mechanical systems, such as pipes, ducts, and boilers, where the mechanical systems are to remain.

TRAFFIC SAFETY

Effective November 30, 2018, the description of the traffic safety worker trade in this County is as follows: Work associated with barricades, hoses and drums used to reduce lane usage on highway work, the installation and removal of temporary, non-temporary or permanent lane, pavement or roadway markings, and the installation and removal of temporary road signs.

CERAMIC TILE FINISHER

The grouting, cleaning, and polishing of all classes of tile, whether for interior or exterior purposes, all burned, glazed or unglazed

products; all composition materials, granite tiles, warning detectable tiles, cement tiles, epoxy composite materials, pavers, glass, mosaics, fiberglass, and all substitute materials, for tile made in tile-like units; all mixtures in tile like form of cement, metals, and other materials that are for and intended for use as a finished floor surface, stair treads, promenade roofs, walks, walls, ceilings, swimming pools, and all other places where tile is to form a finished interior or exterior. The mixing of all setting mortars including but not limited to thin-set mortars, epoxies, wall mud, and any other sand and cement mixtures or adhesives when used in the preparation, installation, repair, or maintenance of tile and/or similar materials. The handling and unloading of all sand, cement, lime, tile, fixtures, equipment, adhesives, or any other materials to be used in the preparation, installation, repair, or maintenance of tile and/or similar materials. Ceramic Tile Finishers shall fill all joints and voids regardless of method on all tile work, particularly and especially after installation of said tile work. Application of any and all protective coverings to all types of tile installations including, but not be limited to, all soap compounds, paper products, tapes, and all polyethylene coverings, plywood, masonite, cardboard, and any new type of products that may be used to protect tile installations, Blastrac equipment, and all floor scarifying equipment used in preparing floors to receive tile. The clean up and removal of all waste and materials. All demolition of existing tile floors and walls to be re-tiled.

COMMUNICATIONS TECHNICIAN

Low voltage installation, maintenance and removal of telecommunication facilities (voice, sound, data and video) including telephone and data inside wire, interconnect, terminal equipment, central offices, PABX, fiber optic cable and equipment, micro waves, V-SAT, bypass, CATV, WAN (wide area networks), LAN (local area networks), and ISDN (integrated system digital network), pulling of wire in raceways, but not the installation of raceways.

MARBLE FINISHER

Loading and unloading trucks, distribution of all materials (all stone, sand, etc.), stocking of floors with material, performing all rigging for heavy work, the handling of all material that may be needed for the installation of such materials, building of scaffolding, polishing if needed, patching, waxing of material if damaged, pointing up, caulking, grouting and cleaning of marble, holding water on diamond or Carborundum blade or saw for setters cutting, use of tub saw or any other saw needed for preparation of material, drilling of holes for wires that anchor material set by setters, mixing up of molding plaster for installation of material, mixing up thin set for the installation of material, mixing up of sand to cement for the installation of material and such other work as may be required in helping a Marble Setter in the handling of all material in the erection or installation of interior marble, slate, travertine, art marble, serpentine, alberene stone, blue stone, granite and other stones (meaning as to stone any foreign or domestic materials as are specified and used in building interiors and exteriors and customarily known as stone in the trade), carrara, sanionyx, vitrolite and similar opaque glass and the laying of all marble tile, terrazzo tile, slate tile and precast tile, steps, risers treads, base, or any other materials that may be used as substitutes for any of the aforementioned materials and which are used on interior and exterior which are installed in a similar manner.

MATERIAL TESTER I: Hand coring and drilling for testing of materials; field inspection of uncured concrete and asphalt.

MATERIAL TESTER II: Field inspection of welds, structural steel, fireproofing, masonry, soil, facade, reinforcing steel, formwork, cured concrete, and concrete and asphalt batch plants; adjusting proportions of bituminous mixtures.

OPERATING ENGINEER - BUILDING

Class 1. Asphalt Plant; Asphalt Spreader; Autograde; Backhoes with Caisson Attachment; Batch Plant; Benoto (requires Two Engineers); Boiler and Throttle Valve; Caisson Rigs; Central Redi-Mix Plant; Combination Back Hoe Front End-loader Machine; Compressor and Throttle Valve; Concrete Breaker (Truck Mounted); Concrete Conveyor; Concrete Conveyor (Truck Mounted); Concrete Paver Over 27E cu. ft; Concrete Paver 27E cu. ft. and Under; Concrete Placer; Concrete Placing Boom; Concrete Pump (Truck Mounted); Concrete Tower; Cranes, All; Cranes, Hammerhead; Cranes, (GCI and similar Type); Creter Crane; Spider Crane; Crusher, Stone, etc.; Derricks, All; Derricks, Traveling; Formless Curb and Gutter Machine; Grader, Elevating; Grouting Machines; Heavy Duty Self-Propelled Transporter or Prime Mover; Highlift Shovels or Front Endloader 2-1/4 yd. and over; Hoists, Elevators,

outside type rack and pinion and similar machines; Hoists, One, Two and Three Drum; Hoists, Two Tugger One Floor; Hydraulic Backhoes; Hydraulic Boom Trucks; Hydro Vac (and similar equipment); Locomotives, All; Motor Patrol; Lubrication Technician; Manipulators; Pile Drivers and Skid Rig; Post Hole Digger; Pre-Stress Machine; Pump Cretes Dual Ram; Pump Cretes: Squeeze Cretes-Screw Type Pumps; Gypsum Bulker and Pump; Raised and Blind Hole Drill; Roto Mill Grinder; Scoops - Tractor Drawn; Slip-Form Paver; Straddle Buggies; Operation of Tie Back Machine; Tournapull; Tractor with Boom and Side Boom; Trenching Machines.

Class 2. Boilers; Broom, All Power Propelled; Bulldozers; Concrete Mixer (Two Bag and Over); Conveyor, Portable; Forklift Trucks; Highlift Shovels or Front Endloaders under 2-1/4 yd.; Hoists, Automatic; Hoists, Inside Elevators; Hoists, Sewer Dragging Machine; Hoists, Tugger Single Drum; Laser Screed; Rock Drill (Self-Propelled); Rock Drill (Truck Mounted); Rollers, All; Steam Generators; Tractors, All; Tractor Drawn Vibratory Roller; Winch Trucks with "A" Frame.

Class 3. Air Compressor; Combination Small Equipment Operator; Generators; Heaters, Mechanical; Hoists, Inside Elevators (remodeling or renovation work); Hydraulic Power Units (Pile Driving, Extracting, and Drilling); Pumps, over 3" (1 to 3 not to exceed a total of 300 ft.); Low Boys; Pumps, Well Points; Welding Machines (2 through 5); Winches, 4 Small Electric Drill Winches.

Class 4. Bobcats and/or other Skid Steer Loaders; Oilers; and Brick Forklift.

Class 5. Assistant Craft Foreman.

Class 6. Gradall.

Class 7. Mechanics; Welders.

OPERATING ENGINEERS - HIGHWAY CONSTRUCTION

Class 1. Asphalt Plant; Asphalt Heater and Planer Combination; Asphalt Heater Scarfire; Asphalt Spreader; Autograder/GOMACO or other similar type machines; ABG Paver; Backhoes with Caisson Attachment; Ballast Regulator; Belt Loader; Caisson Rigs; Car Dumper; Central Redi-Mix Plant; Combination Backhoe Front Endloader Machine, (1 cu. yd. Backhoe Bucket or over or with attachments); Concrete Breaker (Truck Mounted); Concrete Conveyor; Concrete Paver over 27E cu. ft.; Concrete Placer; Concrete Tube Float; Cranes, all attachments; Cranes, Tower Cranes of all types: Creter Crane; Spider Crane; Crusher, Stone, etc.; Derricks, All; Derrick Boats; Derricks, Traveling; Dredges; Elevators, Outside type Rack & Pinion and Similar Machines; Formless Curb and Gutter Machine; Grader, Elevating; Grader, Motor Grader, Motor Patrol, Auto Patrol, Form Grader, Pull Grader, Subgrader; Guard Rail Post Driver Truck Mounted; Hoists, One, Two and Three Drum; Heavy Duty Self-Propelled Transporter or Prime Mover; Hydraulic Backhoes; Backhoes with shear attachments up to 40' of boom reach; Lubrication Technician; Manipulators; Mucking Machine; Pile Drivers and Skid Rig; Pre-Stress Machine; Pump Cretes Dual Ram; Rock Drill - Crawler or Skid Rig; Rock Drill - Truck Mounted; Rock/Track Tamper; Roto Mill Grinder; Slip-Form Paver; Snow Melters; Soil Test Drill Rig (Truck Mounted); Straddle Buggies; Hydraulic Telescoping Form (Tunnel); Operation of Tieback Machine; Tractor Drawn Belt Loader; Tractor Drawn Belt Loader (with attached pusher - two engineers); Tractor with Boom; Tractaire with Attachments; Traffic Barrier Transfer Machine; Trenching; Truck Mounted Concrete Pump with Boom; Raised or Blind Hole Drills (Tunnel Shaft); Underground Boring and/or Mining Machines 5 ft. in diameter and over tunnel, etc; Underground Boring and/or Mining Machines under 5 ft. in diameter; Wheel Excavator; Widener (APSCO).

Class 2. Batch Plant; Bituminous Mixer; Boiler and Throttle Valve; Bulldozers; Car Loader Trailing Conveyors; Combination Backhoe Front Endloader Machine (Less than 1 cu. yd. Backhoe Bucket or over or with attachments); Compressor and Throttle Valve; Compressor, Common Receiver (3); Concrete Breaker or Hydro Hammer; Concrete Grinding Machine; Concrete Mixer or Paver 7S Series to and including 27 cu. ft.; Concrete Spreader; Concrete Curing Machine, Burlap Machine, Belting Machine and Sealing Machine; Concrete Wheel Saw; Conveyor Muck Cars (Haglund or Similar Type); Drills, All; Finishing Machine - Concrete; Highlift Shovels or Front Endloader; Hoist - Sewer Dragging Machine; Hydraulic Boom Trucks (All Attachments); Hydro-Blaster; Hydro Excavating (excluding hose work); Laser Screed; All Locomotives, Dinky; Off-Road Hauling Units (including articulating) Non Self-

Loading Ejection Dump; Pump Cretes: Squeeze Cretes - Screw Type Pumps, Gypsum Bulker and Pump; Roller, Asphalt; Rotary Snow Plows; Rototiller, Seaman, etc., self-propelled; Self-Propelled Compactor; Spreader - Chip - Stone, etc.; Scraper - Single/Twin Engine/Push and Pull; Scraper - Prime Mover in Tandem (Regardless of Size); Tractors pulling attachments, Sheeps Foot, Disc, Compactor, etc.; Tug Boats.

Class 3. Boilers; Brooms, All Power Propelled; Cement Supply Tender; Compressor, Common Receiver (2); Concrete Mixer (Two Bag and Over); Conveyor, Portable; Farm-Type Tractors Used for Mowing, Seeding, etc.; Forklift Trucks; Grouting Machine; Hoists, Automatic; Hoists, All Elevators; Hoists, Tugger Single Drum; Jeep Diggers; Low Boys; Pipe Jacking Machines; Post-Hole Digger; Power Saw, Concrete Power Driven; Pug Mills; Rollers, other than Asphalt; Seed and Straw Blower; Steam Generators; Stump Machine; Winch Trucks with "A" Frame; Work Boats; Tamper-Form-Motor Driven.

Class 4. Air Compressor; Combination - Small Equipment Operator; Directional Boring Machine; Generators; Heaters, Mechanical; Hydraulic Power Unit (Pile Driving, Extracting, or Drilling); Light Plants, All (1 through 5); Pumps, over 3" (1 to 3 not to exceed a total of 300 ft.); Pumps, Well Points; Vacuum Trucks (excluding hose work); Welding Machines (2 through 5); Winches, 4 Small Electric Drill Winches.

Class 5. SkidSteer Loader (all); Brick Forklifts; Oilers.

Class 6. Field Mechanics and Field Welders

Class 7. Dowell Machine with Air Compressor; Gradall and machines of like nature.

OPERATING ENGINEER - FLOATING

Diver, Diver Wet Tender, Diver Tender, ROV Pilot, ROV Tender

TRUCK DRIVER - BUILDING, HEAVY AND HIGHWAY CONSTRUCTION

Class 1. Two or three Axle Trucks. A-frame Truck when used for transportation purposes; Air Compressors and Welding Machines, including those pulled by cars, pick-up trucks and tractors; Ambulances; Batch Gate Lockers; Batch Hopperman; Car and Truck Washers; Carry-alls; Fork Lifts and Hoisters; Helpers; Mechanics Helpers and Greasers; Oil Distributors 2-man operation; Pavement Breakers; Pole Trailer, up to 40 feet; Power Mower Tractors; Self-propelled Chip Spreader; Skipman; Slurry Trucks, 2-man operation; Slurry Truck Conveyor Operation, 2 or 3 man; Teamsters; Unskilled Dumpman; and Truck Drivers hauling warning lights, barricades, and portable toilets on the job site.

Class 2. Four axle trucks; Dump Crets and Adgetors under 7 yards; Dumpsters, Track Trucks, Euclids, Hug Bottom Dump Turnapulls or Turnatrailers when pulling other than self-loading equipment or similar equipment under 16 cubic yards; Mixer Trucks under 7 yards; Ready-mix Plant Hopper Operator, and Winch Trucks, 2 Axles.

Class 3. Five axle trucks; Dump Crets and Adgetors 7 yards and over; Dumpsters, Track Trucks, Euclids, Hug Bottom Dump Turnatrailers or turnapulls when pulling other than self-loading equipment or similar equipment over 16 cubic yards; Explosives and/or Fission Material Trucks; Mixer Trucks 7 yards or over; Mobile Cranes while in transit; Oil Distributors, 1-man operation; Pole Trailer, over 40 feet; Pole and Expandable Trailers hauling material over 50 feet long; Slurry trucks, 1-man operation; Winch trucks, 3 axles or more; Mechanic--Truck Welder and Truck Painter.

Class 4. Six axle trucks; Dual-purpose vehicles, such as mounted crane trucks with hoist and accessories; Foreman; Master Mechanic; Self-loading equipment like P.B. and trucks with scoops on the front.

TERRAZZO FINISHER

The handling of sand, cement, marble chips, and all other materials that may be used by the Mosaic Terrazzo Mechanic, and the mixing, grinding, grouting, cleaning and sealing of all Marble, Mosaic, and Terrazzo work, floors, base, stairs, and wainscoting by

hand or machine, and in addition, assisting and aiding Marble, Masonic, and Terrazzo Mechanics.

Other Classifications of Work:

For definitions of classifications not otherwise set out, the Department generally has on file such definitions which are available. If a task to be performed is not subject to one of the classifications of pay set out, the Department will upon being contacted state which neighboring county has such a classification and provide such rate, such rate being deemed to exist by reference in this document. If no neighboring county rate applies to the task, the Department shall undertake a special determination, such special determination being then deemed to have existed under this determination. If a project requires these, or any classification not listed, please contact IDOL at 217-782-1710 for wage rates or clarifications.

LANDSCAPING

Landscaping work falls under the existing classifications for laborer, operating engineer and truck driver. The work performed by landscape plantsman and landscape laborer is covered by the existing classification of laborer. The work performed by landscape operators (regardless of equipment used or its size) is covered by the classifications of operating engineer. The work performed by landscape truck drivers (regardless of size of truck driven) is covered by the classifications of truck driver.

MATERIAL TESTER & MATERIAL TESTER/INSPECTOR I AND II

Notwithstanding the difference in the classification title, the classification entitled "Material Tester I" involves the same job duties as the classification entitled "Material Tester/Inspector I". Likewise, the classification entitled "Material Tester II" involves the same job duties as the classification entitled "Material Tester/Inspector II".

EXHIBIT B

Cook County Prevailing Wage Rates posted on 7/15/2019

Trade Title	Rg	Type	C	Base	Foreman	Overtime				H/W	Pension	Vac	Trng	Other Ins
						M-F	Sa	Su	Hol					
ASBESTOS ABT-GEN	All	ALL		43.72	44.72	1.5	1.5	2.0	2.0	14.99	13.61	0.00	0.90	
ASBESTOS ABT-MEC	All	BLD		37.88	40.38	1.5	1.5	2.0	2.0	13.42	12.20	0.00	0.72	
BOILERMAKER	All	BLD		50.51	55.05	2.0	2.0	2.0	2.0	6.97	14.65	0.00	1.10	
BRICK MASON	All	BLD		46.88	51.57	1.5	1.5	2.0	2.0	10.85	19.31	0.00	0.95	
CARPENTER	All	ALL		48.55	50.55	1.5	1.5	2.0	2.0	11.79	21.84	0.00	0.73	
CEMENT MASON	All	ALL		46.25	48.25	2.0	1.5	2.0	2.0	14.50	19.04	0.00	1.25	
CERAMIC TILE FINISHER	All	BLD		40.56	40.56	1.5	1.5	2.0	2.0	11.00	12.80	0.00	0.86	
COMMUNICATION ELECTRICIAN	All	BLD		44.86	47.66	1.5	1.5	2.0	2.0	10.22	13.48	1.25	1.15	0.07
ELECTRIC PWR EQMT OP	All	ALL		53.40	58.40	1.5	1.5	2.0	2.0	12.36	17.72	0.00	3.39	
ELECTRIC PWR GRNDMAN	All	ALL		41.65	58.40	1.5	1.5	2.0	2.0	9.64	13.82	0.00	2.65	
ELECTRIC PWR LINEMAN	All	ALL		53.40	58.40	1.5	1.5	2.0	2.0	12.36	17.72	0.00	3.39	
ELECTRICIAN	All	ALL		49.35	52.35	1.5	1.5	2.0	2.0	15.69	17.02	1.25	1.48	0.40
ELEVATOR CONSTRUCTOR	All	BLD		56.61	63.69	2.0	2.0	2.0	2.0	15.58	17.51	4.53	0.62	
FENCE ERECTOR	All	ALL		42.88	44.88	1.5	1.5	2.0	2.0	13.64	14.89	0.00	0.65	
GLAZIER	All	BLD		44.85	46.35	1.5	2.0	2.0	2.0	14.49	22.29	0.00	0.94	
HEAT/FROST INSULATOR	All	BLD		50.50	53.00	1.5	1.5	2.0	2.0	13.42	13.66	0.00	0.72	
IRON WORKER	All	ALL		47.00	50.76	2.0	2.0	2.0	2.0	12.26	23.65	0.00	0.88	
LABORER	All	ALL		43.72	44.47	1.5	1.5	2.0	2.0	14.99	13.61	0.00	0.90	
LATHER	All	ALL		48.55	50.55	1.5	1.5	2.0	2.0	11.79	21.84	0.00	0.73	
MACHINIST	All	BLD		48.93	51.43	1.5	1.5	2.0	2.0	7.68	8.95	1.85	1.32	
MARBLE FINISHER	All	ALL		35.15	48.33	1.5	1.5	2.0	2.0	10.85	17.66	0.00	0.52	
MARBLE MASON	All	BLD		46.03	50.63	1.5	1.5	2.0	2.0	10.85	18.78	0.00	0.64	
MATERIAL TESTER I	All	ALL		33.72		1.5	1.5	2.0	2.0	14.99	13.61	0.00	0.90	
MATERIALS TESTER II	All	ALL		38.72		1.5	1.5	2.0	2.0	14.99	13.61	0.00	0.90	
MILLWRIGHT	All	ALL		48.55	50.55	1.5	1.5	2.0	2.0	11.79	21.84	0.00	0.73	
OPERATING ENGINEER	All	BLD	1	51.10	55.10	2.0	2.0	2.0	2.0	20.50	16.85	2.00	1.65	
OPERATING ENGINEER	All	BLD	2	49.80	55.10	2.0	2.0	2.0	2.0	20.50	16.85	2.00	1.65	
OPERATING ENGINEER	All	BLD	3	47.25	55.10	2.0	2.0	2.0	2.0	20.50	16.85	2.00	1.65	
OPERATING ENGINEER	All	BLD	4	45.50	55.10	2.0	2.0	2.0	2.0	20.50	16.85	2.00	1.65	
OPERATING ENGINEER	All	BLD	5	54.85	55.10	2.0	2.0	2.0	2.0	20.50	16.85	2.00	1.65	
OPERATING ENGINEER	All	BLD	6	52.10	55.10	2.0	2.0	2.0	2.0	20.50	16.85	2.00	1.65	

OPERATING ENGINEER	All	BLD	7	54.10	55.10	2.0	2.0	2.0	2.0	20.50	16.85	2.00	1.65
OPERATING ENGINEER	All	FLT	1	58.20	58.20	1.5	1.5	2.0	2.0	19.65	15.10	2.00	1.40
OPERATING ENGINEER	All	FLT	2	56.70	58.20	1.5	1.5	2.0	2.0	19.65	15.10	2.00	1.40
OPERATING ENGINEER	All	FLT	3	50.45	58.20	1.5	1.5	2.0	2.0	19.65	15.10	2.00	1.40
OPERATING ENGINEER	All	FLT	4	41.95	58.20	1.5	1.5	2.0	2.0	19.65	15.10	2.00	1.40
OPERATING ENGINEER	All	FLT	5	59.70	58.20	1.5	1.5	2.0	2.0	19.65	15.10	2.00	1.40
OPERATING ENGINEER	All	FLT	6	38.00	58.20	1.5	1.5	2.0	2.0	19.65	15.10	2.00	1.40
OPERATING ENGINEER	All	HWY	1	49.30	53.30	1.5	1.5	2.0	2.0	20.50	16.85	2.00	1.65
OPERATING ENGINEER	All	HWY	2	48.75	53.30	1.5	1.5	2.0	2.0	20.50	16.85	2.00	1.65
OPERATING ENGINEER	All	HWY	3	46.70	53.30	1.5	1.5	2.0	2.0	20.50	16.85	2.00	1.65
OPERATING ENGINEER	All	HWY	4	45.30	53.30	1.5	1.5	2.0	2.0	20.50	16.85	2.00	1.65
OPERATING ENGINEER	All	HWY	5	44.10	53.30	1.5	1.5	2.0	2.0	20.50	16.85	2.00	1.65
OPERATING ENGINEER	All	HWY	6	52.30	53.30	1.5	1.5	2.0	2.0	20.50	16.85	2.00	1.65
OPERATING ENGINEER	All	HWY	7	50.30	53.30	1.5	1.5	2.0	2.0	20.50	16.85	2.00	1.65
ORNAMENTAL IRON WORKER	All	ALL		50.05	52.55	2.0	2.0	2.0	2.0	14.14	21.13	0.00	1.25
PAINTER	All	ALL		47.30	53.21	1.5	1.5	1.5	2.0	12.01	12.74	0.00	1.87
PAINTER - SIGNS	All	BLD		39.06	43.86	1.5	1.5	2.0	2.0	2.67	3.32	0.00	0.00
PILEDRIIVER	All	ALL		48.55	50.55	1.5	1.5	2.0	2.0	11.79	21.84	0.00	0.73
PIPEFITTER	All	BLD		49.60	52.60	1.5	1.5	2.0	2.0	10.75	19.85	0.00	2.67
PLASTERER	All	BLD		44.50	47.17	1.5	1.5	2.0	2.0	14.50	17.29	0.00	1.50
PLUMBER	All	BLD		51.00	54.05	1.5	1.5	2.0	2.0	15.37	14.75	0.00	1.35
ROOFER	All	BLD		44.60	48.60	1.5	1.5	2.0	2.0	10.38	12.74	0.00	0.58
SHEETMETAL WORKER	All	BLD		45.50	49.14	1.5	1.5	2.0	2.0	11.70	25.58	0.00	0.86
SIGN HANGER	All	BLD		32.68	35.29	1.5	1.5	2.0	2.0	5.40	3.75	0.00	0.00
SPRINKLER FITTER	All	BLD		50.15	52.65	1.5	1.5	2.0	2.0	13.50	16.60	0.00	0.65
STEEL ERECTOR	All	ALL		42.07	44.07	2.0	2.0	2.0	2.0	13.45	19.59	0.00	0.35
STONE MASON	All	BLD		46.88	51.57	1.5	1.5	2.0	2.0	10.85	19.31	0.00	0.95
TERRAZZO FINISHER	All	BLD		42.54	42.54	1.5	1.5	2.0	2.0	11.00	14.64	0.00	0.88
TERRAZZO MASON	All	BLD		46.38	49.88	1.5	1.5	2.0	2.0	11.00	16.09	0.00	0.93
TILE MASON	All	BLD		47.50	51.50	1.5	1.5	2.0	2.0	11.00	16.06	0.00	0.93
TRAFFIC SAFETY WORKER	All	HWY		37.75	39.35	1.5	1.5	2.0	2.0	9.30	9.87	0.00	0.30
TRUCK DRIVER	E	ALL	1	36.45	37.10	1.5	1.5	2.0	2.0	9.68	13.25	0.00	0.15
TRUCK DRIVER	E	ALL	2	36.70	37.10	1.5	1.5	2.0	2.0	9.68	13.25	0.00	0.15
TRUCK DRIVER	E	ALL	3	36.90	37.10	1.5	1.5	2.0	2.0	9.68	13.25	0.00	0.15
TRUCK DRIVER	E	ALL	4	37.10	37.10	1.5	1.5	2.0	2.0	9.68	13.25	0.00	0.15
TRUCK DRIVER	W	ALL	1	37.36	37.91	1.5	1.5	2.0	2.0	9.00	11.64	0.00	0.15

TRUCK DRIVER	W	ALL	2	37.51	37.91	1.5	1.5	2.0	2.0	9.00	11.64	0.00	0.15
TRUCK DRIVER	W	ALL	3	37.71	37.91	1.5	1.5	2.0	2.0	9.00	11.64	0.00	0.15
TRUCK DRIVER	W	ALL	4	37.91	37.91	1.5	1.5	2.0	2.0	9.00	11.64	0.00	0.15
TUCK POINTER	All	BLD		46.50	47.50	1.5	1.5	2.0	2.0	8.34	18.40	0.00	0.93

Legend

Rg Region

Type Trade Type - All,Highway,Building,Floating,Oil & Chip,Rivers

C Class

Base Base Wage Rate

OT M-F Unless otherwise noted, OT pay is required for any hour greater than 8 worked each day, Mon through Fri. The number listed is the multiple of the base wage.

OT Sa Overtime pay required for every hour worked on Saturdays

OT Su Overtime pay required for every hour worked on Sundays

OT Hol Overtime pay required for every hour worked on Holidays

H/W Health/Welfare benefit

Vac Vacation

Trng Training

Other Ins Employer hourly cost for any other type(s) of insurance provided for benefit of worker.

Explanations COOK COUNTY

The following list is considered as those days for which holiday rates of wages for work performed apply: New Years Day, Memorial Day, Fourth of July, Labor Day, Thanksgiving Day, Christmas Day and Veterans Day in some classifications/counties. Generally, any of these holidays which fall on a Sunday is celebrated on the following Monday. This then makes work performed on that Monday payable at the appropriate overtime rate for holiday pay. Common practice in a given local may alter certain days of celebration. If in doubt, please check with IDOL.

TRUCK DRIVERS (WEST) - That part of the county West of Barrington Road.

EXPLANATION OF CLASSES

ASBESTOS - GENERAL - removal of asbestos material/mold and hazardous materials from any place in a building, including mechanical systems where those mechanical systems are to be removed. This includes the removal of asbestos materials/mold and hazardous materials from ductwork or pipes in a building when the building is to be demolished at the time or at some close future date. ASBESTOS - MECHANICAL - removal of asbestos material from mechanical systems, such as pipes, ducts, and boilers, where the mechanical systems are to remain.

CERAMIC TILE FINISHER

The grouting, cleaning, and polishing of all classes of tile, whether for interior or exterior purposes, all burned, glazed or unglazed products; all composition materials, granite tiles, warning detectable tiles, cement tiles, epoxy composite materials, pavers, glass, mosaics, fiberglass, and all substitute materials, for tile made in tile-like units; all mixtures in tile like form of cement, metals, and other materials that are for and intended for use as a finished floor surface, stair treads, promenade roofs, walks, walls, ceilings, swimming pools, and all other places where tile is to form a finished interior or exterior. The mixing of all setting mortars including but not limited to thin-set mortars, epoxies, wall mud, and any other sand and cement mixtures or adhesives when used in the preparation, installation, repair, or maintenance of tile and/or similar materials. The handling and unloading of all

sand, cement, lime, tile, fixtures, equipment, adhesives, or any other materials to be used in the preparation, installation, repair, or maintenance of tile and/or similar materials. Ceramic Tile Finishers shall fill all joints and voids regardless of method on all tile work, particularly and especially after installation of said tile work. Application of any and all protective coverings to all types of tile installations including, but not be limited to, all soap compounds, paper products, tapes, and all polyethylene coverings, plywood, masonite, cardboard, and any new type of products that may be used to protect tile installations, Blastrac equipment, and all floor scarifying equipment used in preparing floors to receive tile. The clean up and removal of all waste and materials. All demolition of existing tile floors and walls to be re-tiled.

COMMUNICATIONS ELECTRICIAN

Installation, operation, inspection, maintenance, repair and service of radio, television, recording, voice sound vision production and reproduction, telephone and telephone interconnect, facsimile, data apparatus, coaxial, fibre optic and wireless equipment, appliances and systems used for the transmission and reception of signals of any nature, business, domestic, commercial, education, entertainment, and residential purposes, including but not limited to, communication and telephone, electronic and sound equipment, fibre optic and data communication systems, and the performance of any task directly related to such installation or service whether at new or existing sites, such tasks to include the placing of wire and cable and electrical power conduit or other raceway work within the equipment room and pulling wire and/or cable through conduit and the installation of any incidental conduit, such that the employees covered hereby can complete any job in full.

MARBLE FINISHER

Loading and unloading trucks, distribution of all materials (all stone, sand, etc.), stocking of floors with material, performing all rigging for heavy work, the handling of all material that may be needed for the installation of such materials, building of scaffolding, polishing if needed, patching, waxing of material if damaged, pointing up, caulking, grouting and cleaning of marble, holding water on diamond or Carborundum blade or saw for setters cutting, use of tub saw or any other saw needed for preparation of material, drilling of holes for wires that anchor material set by setters, mixing up of molding plaster for installation of material, mixing up thin set for the installation of material, mixing up of sand to cement for the installation of material and such other work as may be required in helping a Marble Setter in the handling of all material in the erection or installation of interior marble, slate, travertine, art marble, serpentine, alberene stone, blue stone, granite and other stones (meaning as to stone any foreign or domestic materials as are specified and used in building interiors and exteriors and customarily known as stone in the trade), carrara, sanionyx, vitrolite and similar opaque glass and the laying of all marble tile, terrazzo tile, slate tile and precast tile, steps, risers treads, base, or any other materials that may be used as substitutes for any of the aforementioned materials and which are used on interior and exterior which are installed in a similar manner.

MATERIAL TESTER I: Hand coring and drilling for testing of materials; field inspection of uncured concrete and asphalt.

MATERIAL TESTER II: Field inspection of welds, structural steel, fireproofing, masonry, soil, facade, reinforcing steel, formwork, cured concrete, and concrete and asphalt batch plants; adjusting proportions of bituminous mixtures.

OPERATING ENGINEER - BUILDING

Class 1. Asphalt Plant; Asphalt Spreader; Autograde; Backhoes with Caisson Attachment; Batch Plant; Benoto (requires Two Engineers); Boiler and Throttle Valve; Caisson Rigs; Central Redi-Mix Plant; Combination Back Hoe Front End-loader Machine; Compressor and Throttle Valve; Concrete Breaker (Truck Mounted); Concrete Conveyor; Concrete Conveyor (Truck Mounted); Concrete Paver Over 27E cu. ft; Concrete Paver 27E cu. ft. and Under; Concrete Placer; Concrete Placing Boom; Concrete Pump (Truck Mounted); Concrete Tower; Cranes, All; Cranes, Hammerhead; Cranes, (GCI and similar Type); Creter Crane; Spider Crane; Crusher, Stone, etc.; Derricks, All; Derricks, Traveling; Formless Curb and Gutter Machine; Grader, Elevating; Grouting Machines; Heavy Duty Self-Propelled Transporter or Prime Mover; Highlift Shovels or Front Endloader 2-1/4 yd. and over; Hoists, Elevators, outside type rack and pinion and similar machines; Hoists, One, Two and Three Drum; Hoists, Two Tugger One Floor; Hydraulic Backhoes; Hydraulic Boom Trucks; Hydro Vac (and similar equipment); Locomotives, All; Motor Patrol; Lubrication Technician;

Manipulators; Pile Drivers and Skid Rig; Post Hole Digger; Pre-Stress Machine; Pump Cretes Dual Ram; Pump Cretes: Squeeze Cretes-Screw Type Pumps; Gypsum Bulker and Pump; Raised and Blind Hole Drill; Roto Mill Grinder; Scoops - Tractor Drawn; Slip-Form Paver; Straddle Buggies; Operation of Tie Back Machine; Tournapull; Tractor with Boom and Side Boom; Trenching Machines.

Class 2. Boilers; Broom, All Power Propelled; Bulldozers; Concrete Mixer (Two Bag and Over); Conveyor, Portable; Forklift Trucks; Highlift Shovels or Front Endloaders under 2-1/4 yd.; Hoists, Automatic; Hoists, Inside Elevators; Hoists, Sewer Dragging Machine; Hoists, Tugger Single Drum; Laser Screed; Rock Drill (Self-Propelled); Rock Drill (Truck Mounted); Rollers, All; Steam Generators; Tractors, All; Tractor Drawn Vibratory Roller; Winch Trucks with "A" Frame.

Class 3. Air Compressor; Combination Small Equipment Operator; Generators; Heaters, Mechanical; Hoists, Inside Elevators (remodeling or renovation work); Hydraulic Power Units (Pile Driving, Extracting, and Drilling); Pumps, over 3" (1 to 3 not to exceed a total of 300 ft.); Low Boys; Pumps, Well Points; Welding Machines (2 through 5); Winches, 4 Small Electric Drill Winches.

Class 4. Bobcats and/or other Skid Steer Loaders; Oilers; and Brick Forklift.

Class 5. Assistant Craft Foreman.

Class 6. Gradall.

Class 7. Mechanics; Welders.

OPERATING ENGINEERS - HIGHWAY CONSTRUCTION

Class 1. Asphalt Plant; Asphalt Heater and Planer Combination; Asphalt Heater Scarfire; Asphalt Spreader; Autograder/GOMACO or other similar type machines; ABG Paver; Backhoes with Caisson Attachment; Ballast Regulator; Belt Loader; Caisson Rigs; Car Dumper; Central Redi-Mix Plant; Combination Backhoe Front Endloader Machine, (1 cu. yd. Backhoe Bucket or over or with attachments); Concrete Breaker (Truck Mounted); Concrete Conveyor; Concrete Paver over 27E cu. ft.; Concrete Placer; Concrete Tube Float; Cranes, all attachments; Cranes, Tower Cranes of all types: Creter Crane; Spider Crane; Crusher, Stone, etc.; Derricks, All; Derrick Boats; Derricks, Traveling; Dredges; Elevators, Outside type Rack & Pinion and Similar Machines; Formless Curb and Gutter Machine; Grader, Elevating; Grader, Motor Grader, Motor Patrol, Auto Patrol, Form Grader, Pull Grader, Subgrader; Guard Rail Post Driver Truck Mounted; Hoists, One, Two and Three Drum; Heavy Duty Self-Propelled Transporter or Prime Mover; Hydraulic Backhoes; Backhoes with shear attachments up to 40' of boom reach; Lubrication Technician; Manipulators; Mucking Machine; Pile Drivers and Skid Rig; Pre-Stress Machine; Pump Cretes Dual Ram; Rock Drill - Crawler or Skid Rig; Rock Drill - Truck Mounted; Rock/Track Tamper; Roto Mill Grinder; Slip-Form Paver; Snow Melters; Soil Test Drill Rig (Truck Mounted); Straddle Buggies; Hydraulic Telescoping Form (Tunnel); Operation of Tieback Machine; Tractor Drawn Belt Loader; Tractor Drawn Belt Loader (with attached pusher - two engineers); Tractor with Boom; Tractaire with Attachments; Traffic Barrier Transfer Machine; Trenching; Truck Mounted Concrete Pump with Boom; Raised or Blind Hole Drills (Tunnel Shaft); Underground Boring and/or Mining Machines 5 ft. in diameter and over tunnel, etc; Underground Boring and/or Mining Machines under 5 ft. in diameter; Wheel Excavator; Widener (APSCO).

Class 2. Batch Plant; Bituminous Mixer; Boiler and Throttle Valve; Bulldozers; Car Loader Trailing Conveyors; Combination Backhoe Front Endloader Machine (Less than 1 cu. yd. Backhoe Bucket or over or with attachments); Compressor and Throttle Valve; Compressor, Common Receiver (3); Concrete Breaker or Hydro Hammer; Concrete Grinding Machine; Concrete Mixer or Paver 7S Series to and including 27 cu. ft.; Concrete Spreader; Concrete Curing Machine, Burlap Machine, Belting Machine and Sealing Machine; Concrete Wheel Saw; Conveyor Muck Cars (Haglund or Similar Type); Drills, All; Finishing Machine - Concrete; Highlift Shovels or Front Endloader; Hoist - Sewer Dragging Machine; Hydraulic Boom Trucks (All Attachments); Hydro-Blaster; Hydro Excavating (excluding hose work); Laser Screed; All Locomotives, Dinky; Off-Road Hauling Units (including articulating) Non Self-Loading Ejection Dump; Pump Cretes: Squeeze Cretes - Screw Type Pumps, Gypsum Bulker and Pump; Roller, Asphalt; Rotary Snow Plows; Rototiller, Seaman, etc., self-propelled; Self-Propelled Compactor; Spreader - Chip - Stone, etc.; Scraper - Single/Twin

Engine/Push and Pull; Scraper - Prime Mover in Tandem (Regardless of Size); Tractors pulling attachments, Sheeps Foot, Disc, Compactor, etc.; Tug Boats.

Class 3. Boilers; Brooms, All Power Propelled; Cement Supply Tender; Compressor, Common Receiver (2); Concrete Mixer (Two Bag and Over); Conveyor, Portable; Farm-Type Tractors Used for Mowing, Seeding, etc.; Forklift Trucks; Grouting Machine; Hoists, Automatic; Hoists, All Elevators; Hoists, Tugger Single Drum; Jeep Diggers; Low Boys; Pipe Jacking Machines; Post-Hole Digger; Power Saw, Concrete Power Driven; Pug Mills; Rollers, other than Asphalt; Seed and Straw Blower; Steam Generators; Stump Machine; Winch Trucks with "A" Frame; Work Boats; Tamper-Form-Motor Driven.

Class 4. Air Compressor; Combination - Small Equipment Operator; Directional Boring Machine; Generators; Heaters, Mechanical; Hydraulic Power Unit (Pile Driving, Extracting, or Drilling); Light Plants, All (1 through 5); Pumps, over 3" (1 to 3 not to exceed a total of 300 ft.); Pumps, Well Points; Vacuum Trucks (excluding hose work); Welding Machines (2 through 5); Winches, 4 Small Electric Drill Winches.

Class 5. SkidSteer Loader (all); Brick Forklifts; Oilers.

Class 6. Field Mechanics and Field Welders

Class 7. Dowell Machine with Air Compressor; Gradall and machines of like nature.

OPERATING ENGINEER - FLOATING

Class 1. Craft Foreman; Master Mechanic; Diver/Wet Tender; Engineer; Engineer (Hydraulic Dredge).

Class 2. Crane/Backhoe Operator; Boat Operator with towing endorsement; Mechanic/Welder; Assistant Engineer (Hydraulic Dredge); Leverman (Hydraulic Dredge); Diver Tender.

Class 3. Deck Equipment Operator, Machineryman, Maintenance of Crane (over 50 ton capacity) or Backhoe (115,000 lbs. or more); Tug/Launch Operator; Loader/Dozer and like equipment on Barge, Breakwater Wall, Slip/Dock, or Scow, Deck Machinery, etc.

Class 4. Deck Equipment Operator, Machineryman/Fireman (4 Equipment Units or More); Off Road Trucks; Deck Hand, Tug Engineer, Crane Maintenance (50 Ton Capacity and Under) or Backhoe Weighing (115,000 pounds or less); Assistant Tug Operator.

Class 5. Friction or Lattice Boom Cranes.

Class 6. ROV Pilot, ROV Tender

TERRAZZO FINISHER

The handling of sand, cement, marble chips, and all other materials that may be used by the Mosaic Terrazzo Mechanic, and the mixing, grinding, grouting, cleaning and sealing of all Marble, Mosaic, and Terrazzo work, floors, base, stairs, and wainscoting by hand or machine, and in addition, assisting and aiding Marble, Masonic, and Terrazzo Mechanics.

TRAFFIC SAFETY

Effective November 30, 2018, the description of the traffic safety worker trade in this County is as follows: Work associated with barricades, horses and drums used to reduce lane usage on highway work, the installation and removal of temporary, non-temporary or permanent lane, pavement or roadway markings, and the installation and removal of temporary road signs.

TRUCK DRIVER - BUILDING, HEAVY AND HIGHWAY CONSTRUCTION - EAST & WEST

Class 1. Two or three Axle Trucks. A-frame Truck when used for transportation purposes; Air Compressors and Welding Machines, including those pulled by cars, pick-up trucks and tractors; Ambulances; Batch Gate Lockers; Batch Hopperman; Car and Truck Washers; Carry-alls; Fork Lifts and Hoisters; Helpers; Mechanics Helpers and Greasers; Oil Distributors 2-man operation; Pavement Breakers; Pole Trailer, up to 40 feet; Power Mower Tractors; Self-propelled Chip Spreader; Skipman; Slurry Trucks, 2-man operation; Slurry Truck Conveyor Operation, 2 or 3 man; Teamsters; Unskilled Dumpman; and Truck Drivers hauling warning lights, barricades, and portable toilets on the job site.

Class 2. Four axle trucks; Dump Crets and Adgetors under 7 yards; Dumpsters, Track Trucks, Euclids, Hug Bottom Dump Turnapulls or Turnatrailers when pulling other than self-loading equipment or similar equipment under 16 cubic yards; Mixer Trucks under 7 yards; Ready-mix Plant Hopper Operator, and Winch Trucks, 2 Axles.

Class 3. Five axle trucks; Dump Crets and Adgetors 7 yards and over; Dumpsters, Track Trucks, Euclids, Hug Bottom Dump Turnatrailers or turnapulls when pulling other than self-loading equipment or similar equipment over 16 cubic yards; Explosives and/or Fission Material Trucks; Mixer Trucks 7 yards or over; Mobile Cranes while in transit; Oil Distributors, 1-man operation; Pole Trailer, over 40 feet; Pole and Expandable Trailers hauling material over 50 feet long; Slurry trucks, 1-man operation; Winch trucks, 3 axles or more; Mechanic--Truck Welder and Truck Painter.

Class 4. Six axle trucks; Dual-purpose vehicles, such as mounted crane trucks with hoist and accessories; Foreman; Master Mechanic; Self-loading equipment like P.B. and trucks with scoops on the front.

Other Classifications of Work:

For definitions of classifications not otherwise set out, the Department generally has on file such definitions which are available. If a task to be performed is not subject to one of the classifications of pay set out, the Department will upon being contacted state which neighboring county has such a classification and provide such rate, such rate being deemed to exist by reference in this document. If no neighboring county rate applies to the task, the Department shall undertake a special determination, such special determination being then deemed to have existed under this determination. If a project requires these, or any classification not listed, please contact IDOL at 217-782-1710 for wage rates or clarifications.

LANDSCAPING

Landscaping work falls under the existing classifications for laborer, operating engineer and truck driver. The work performed by landscape plantsman and landscape laborer is covered by the existing classification of laborer. The work performed by landscape operators (regardless of equipment used or its size) is covered by the classifications of operating engineer. The work performed by landscape truck drivers (regardless of size of truck driven) is covered by the classifications of truck driver.

MATERIAL TESTER & MATERIAL TESTER/INSPECTOR I AND II

Notwithstanding the difference in the classification title, the classification entitled "Material Tester I" involves the same job duties as the classification entitled "Material Tester/Inspector I". Likewise, the classification entitled "Material Tester II" involves the same job duties as the classification entitled "Material Tester/Inspector II".

NOTICE OF PREVAILING WAGE DETERMINATION

On August 15, 2019, in accordance with the Illinois Prevailing Wage Act, the DuPage Water Commission adopted Ordinance No. O-5-19, being "An Ordinance Determining the Prevailing Rate of Wages in DuPage County and Cook County." The Ordinance establishes the prevailing rate of wages for various construction trades working on Commission public works construction projects in DuPage and Cook Counties. The prevailing rate of wages established in the Ordinance are the same as the prevailing rate of wages determined by the Illinois Department of Labor as of July 2019 for construction work in those localities. As changes are made to the Department's August determinations, those changes will supersede the Commission's September determinations and will apply to Commission public works construction. A copy of the Ordinance is available upon request at the main office of the Commission, 600 East Butterfield Road, Elmhurst, Illinois.

DATE: August 15, 2019

REQUEST FOR BOARD ACTION

AGENDA SECTION	Engineering & Construction Committee	ORIGINATING DEPARTMENT	Operations
ITEM	A Resolution Directing Advertisement for Bids on a Contract for 36-Month Maintenance, Parts and Repair Service for Large Electric Motors Resolution No. R-22-19	APPROVAL <i>MW JY</i>	<i>CMP</i>
Account Number: 01-60-662100 (No Cost for This Action)			
<p>Resolution No. R-22-19 would authorize advertisement for bids on a Contract for 36-Month Maintenance, Parts and Repair Service for Large Electric Motors, five (5) horsepower and larger electric motors including ancillary equipment, and would establish all requirements necessary for the bidding, for the awarding of the contract, and for the approval of the contractor's bonds, all as required by state statute.</p> <p>While the primary focus of the contract would be the Commission's High Lift Pump Motors consisting of two (2) 800 horsepower and seven (7) 1750 horsepower electric motors, from time to time Staff is in need of repairs to smaller motors when it's economically feasible to repair rather than replace.</p> <p>The intent is to receive proposals that include unit prices for parts, material and labor services to be used on an as needed basis for general service and also for emergency service.</p> <p>There is no cost component for this action.</p>			
MOTION: To adopt Resolution No. R-22-19.			

DuPAGE WATER COMMISSION

RESOLUTION NO. R-22-19

A RESOLUTION DIRECTING ADVERTISEMENT
FOR BIDS ON A CONTRACT FOR 36-MONTH MAINTENANCE, PARTS AND REPAIR
SERVICE FOR LARGE ELECTRIC MOTORS

BE IT RESOLVED by the Board of Commissioners of the DuPage Water Commission as follows:

SECTION ONE: Advertisement for Bids. The General Manager is hereby authorized and directed to advertise for bids on a Contract for 36-Month Maintenance, Parts and Repair Service for Large Electric Motors (the "Contract") in accordance with the requirements of 65 ILCS 5/11-135-5.

SECTION TWO: Notice Inviting Bids. The Notice inviting bids on the Contract shall be in substantially the form of the "Request for Proposals" attached hereto as Exhibit A and by this reference incorporated herein and made a part hereof.

SECTION THREE: Requirements for Bidding. Sealed envelopes or packages containing proposals for the performance of the Contract shall be submitted to the Commission in accordance with the "Delivery of Proposals" attached hereto as Exhibit A and by this reference incorporated herein and made a part hereof.

SECTION FOUR: Awarding of Contract. The Commission will award the Contract to a bidder whose proposal is found to be in the best interests of the Commission. The bidder who is to receive an award shall be determined in accordance with Article VIII of the Commission By-Laws and the Instructions to Bidders substantially in the form attached hereto as Exhibit B.

SECTION FIVE: Approval of Bonds. The approval of the contractor's faithful performance bond shall be subject to the requirements set forth under the subheading

Resolution No. R-22-19

“Performance and Payment Bonds” in the Request for Proposals attached hereto as Exhibit A.

SECTION SIX: Effective Date. This resolution shall be in full force and effect from and after its adoption.

AYES:

NAYS:

ABSENT:

ADOPTED this _____ day of _____, 2019.

Chairman

ATTEST:

Clerk

Board/Resolutions/R-22-19.docx

EXHIBIT A

**DuPAGE WATER COMMISSION
REQUEST FOR PROPOSALS**

OWNER:

DuPage Water Commission
600 East Butterfield Road
Elmhurst, Illinois 60126-4642

Owner will receive sealed proposals for the Work generally described as follows:

CONTRACT FOR 36-MONTH MAINTENANCE, PARTS AND REPAIR SERVICE FOR LARGE ELECTRIC MOTORS

TO BE SUBMITTED TO DuPage Water Commission, 600 East Butterfield Road, Elmhurst, Illinois 60126-4642, Attention John F. Spatz, Jr., General Manager, BEFORE 1:00 P.M., September 30th, 2019.

INSTRUCTIONS TO BIDDERS

Work Site

DuPage Pumping Station, 600 E. Butterfield Rd., Elmhurst, IL 60126.

The Bid Package

The Bid Package consists of the following documents, all of which are by this reference made a part of this Request for Proposals as though fully set forth herein: Request for Proposals; Addenda, if issued; Bidder's Contract/Proposal, including all of its Attachments and Appendices, if any; Other Information Submitted by Bidder, if requested; and Owner's Notification of Acceptance.

Inspection and Examination

A copy of the Bid Package may be obtained at the office of Owner as listed above. In making copies of the Bid Package available to prospective Bidders, Owner does so only for the purpose of obtaining Bidder's Proposals and such provision does not confer a license or grant for any other use.

Each prospective bidder shall, before submitting its proposal, carefully examine the Contract/Proposal form attached to this Request for Proposals. Each bidder shall also inspect in detail the Work Site described in the Contract/Proposal form and the surrounding area and shall familiarize itself with all conditions under which the Work is to be performed; with the obstacles, unusual conditions, or difficulties that may be encountered, whether or not referred to in the Contract/Proposal; and with all other relevant matters concerning the Work Site and the surrounding area. The bidder whose Contract/ Proposal is accepted will be responsible for all errors in its proposal, including those resulting from its failure or neglect to make a thorough examination and investigation of the Contract/Proposal, and the conditions of the Work Site and the surrounding area.

Owner will provide access to the Work Site for such pre-bid inspections from 7:00 a.m. to 2:00 p.m. local time and by appointment only. Contact Owner's Operations Supervisor, Michael Weed, at 630-834-0100, for an appointment.

Preparation of Proposals

All proposals for the Work shall be made only on the blank Contract/Proposal form attached to this Request for Proposals, and shall be complete with a price for each and every item named in the Schedule of Prices attached to the Contract/Proposal form as Attachment A. All proposals shall be signed by an authorized official. Proposals that contain omissions, erasures, alterations, or additions not called for, conditional or alternate bids unless called for, or that contain irregularities of any kind may be rejected.

The work furnished under this contract, and all of its components, shall be provided, performed, and completed in compliance with all applicable federal, state, and local laws, orders, rules, and regulations, as they may be modified or amended from time to time, including without limitation the Prevailing Wage Act, 820 ILCS 130/0.01 et seq.

Clarifications

Owner reserves the right to make clarifications, corrections, or changes in this Request for Proposals at any time prior to the time proposals are opened. All bidders or prospective bidders will be informed of said clarifications, corrections, or changes. If any prospective bidder has questions about this Request for Proposals, contact Michael Weed, Operations Supervisor, at 630-834-0100 between the hours of 6:00 AM and 3:00 PM.

Delivery of Proposals

Each proposal shall be submitted in a sealed envelope plainly marked with the title of the contract and bidder's full legal name and shall be addressed and delivered to the place and before the time set forth above. Proposals may be delivered by mail or in person. Proposals received after the time specified above will be returned unopened.

Opening of Proposals

Proposals will be publicly opened and read at the time and place specified above. Bidders, their authorized agents, and interested parties are invited to be present.

Resolution No. R-22-19

Withdrawal of Proposals

No proposal shall be withdrawn for a period of 60 days after the opening of any proposal.

Rejection of Proposals

Proposals that are not submitted on the Contract/Proposal form or that are not prepared in accordance with these Instructions to Bidders may be rejected. If not rejected, Owner may demand correction of any deficiency and accept the deficiently prepared proposal upon compliance with these Instructions to Bidders.

Acceptance of Proposals

Proposals are being solicited pursuant to, and will be acted upon, in accordance with Article VIII, Section 5 of the Owner's By-Laws. Proposals submitted are offers only and the decision to accept or reject is a function of quality, reliability, capability, reputation, and expertise of the bidders.

Owner reserves the right to accept the proposal that is, in its judgment, the best and most favorable to the interests of Owner and to the public; to reject the low price proposal; to accept any item of any proposal; to reject any and all proposals; and to waive irregularities and informalities in any proposal submitted or in the request for proposal process; provided, however, the waiver of any prior defect or informality shall not be considered a waiver of any future or similar defect or informality. Bidders should not rely upon, or anticipate, such waivers in submitting their proposal.

Owner shall notify the successful Bidder's of the acceptance of its proposal by the transmission of the Acceptance in the form attached to the Contract/Proposal as Attachment E. Upon the transmission of the Acceptance by the Owner, the Contract Documents shall become the contract for the Work.

DATED this 15th day of August, 2019.

DUPAGE WATER COMMISSION

By: /s/ John F. Spatz, Jr.
General Manager

DuPAGE WATER COMMISSION

CONTRACT/PROPOSAL

CONTRACT FOR 36-MONTH MAINTENANCE, PARTS AND REPAIR SERVICE FOR LARGE ELECTRIC MOTORS

Full Name of Bidder _____ ("Bidder")
Principal Office Address _____
Local Office Address _____
Contact Person _____ Telephone Number _____

TO: DuPage Water Commission ("Owner")
600 East Butterfield Road
Elmhurst, Illinois 60126-4642
Attention: John F. Spatz, Jr.
General Manager

Bidder warrants and represents that Bidder has carefully reviewed and understood all documents included, referred to, or mentioned in this bound set of documents, including Addenda Nos. _____ [if none, write "NONE"], which are securely stapled to the end of this Contract/Proposal.

Terms defined in the Request for Proposals shall have the same meanings in all Contract Documents, including this Contract/Proposal, as ascribed to those terms in the Request for Proposals.

1. Work Proposal

A. Contract and Work. Upon the transmission of the Owner's written notification of Acceptance in the form included herein as Attachment E, Bidder proposes, and agrees, that Bidder shall, at its sole cost and expense, provide, perform, and complete, in the manner specified and described, and upon the terms and conditions set forth, in this Contract/Proposal and the remaining Contract Documents, all of the following, all of which is herein referred to as the "Work":

1. Labor, Equipment, Materials and Supplies. Provide, perform, and complete, in the manner specified and described in this Contract/Proposal, and the remaining Contract Documents, all necessary work, labor, services, transportation, equipment, materials, supplies, information, data, and other means and items.
2. Permits. Procure and furnish all permits, licenses, and other governmental approvals and authorizations necessary in connection therewith;
3. Insurance. Procure all insurance specified in this Contract/Proposal;
4. Taxes. Pay all applicable federal, state, and local taxes;

5. Miscellaneous. Do all other things required of Bidder by this Contract/Proposal; and

6. Quality. Provide, perform, and complete all of the foregoing in a proper and workmanlike manner, consistent with highest standards of professional and construction practices, in full compliance with, and as required by or pursuant, to this Contract/Proposal, and with the greatest economy, efficiency, and expedition consistent therewith, with only new, undamaged, and first quality equipment, materials, and supplies.

B. Performance Standards. If this Contract/Proposal is accepted, Bidder proposes, and agrees, that all Work shall be fully provided, performed, and completed in accordance with the Specifications attached hereto and by this reference made a part of this Contract/Proposal as Attachment A. No provision of any referenced standard, specification, manual, or code shall change the duties and responsibilities of Owner or Bidder from those set forth in these Contract Documents.

C. Responsibility for Damage or Loss. If this Contract/Proposal is accepted, Bidder proposes, and agrees, that Bidder shall be responsible and liable for, and shall promptly and without charge to Owner repair or replace, damage done to, and any loss or injury suffered by, Owner, the Work, or other property or persons as a result of the Work.

D. Inspection/Testing/Rejection. Owner shall have the right to inspect all or any part of the Work and to reject all or any part of the Work that is, in Owner's judgment, defective or damaged or that in any way fails to conform strictly to the requirements of these Contract Documents and Owner, without limiting its other rights or remedies, may require correction or replacement at Bidder's cost, perform or have performed all Work necessary to complete or correct all or any part of the Work that is defective, damaged, or nonconforming and charge Bidder with any excess cost incurred thereby, or cancel all or any part of any order or these Contract Documents. Work so rejected may be returned or held at Bidder's expense and risk.

Resolution No. R-22-19

applicable Unit Price set forth in the Schedule of Prices attached hereto as Attachment A.

2. Contract Price Proposal

If this Contract/Proposal is accepted, Bidder proposes, and agrees, that Bidder shall take in full payment for all Work and other matters set forth under Section 1 above, including overhead and profit; taxes, contributions, and premiums; and compensation to all subcontractors and suppliers, the compensation set forth below.

2. The Contract Price shall be adjusted to reflect the actual number Unit Price Items acceptable to Owner upon final acceptance of the Work by Owner.

A. SCHEDULE OF PRICES

For providing, performing, and completing all Work, the sum of the products resulting from multiplying the actual number of acceptable units of Unit Price Items listed in the Schedule of Prices attached hereto as Attachment A by the Unit Price set forth the Schedule of Prices attached hereto as Attachment A for such Unit Price Item.

D. TIME OF PAYMENT

Owner shall pay to Bidder the value of Work, determined in the manner set forth above. Payment shall be in an amount equal to the sum of the number of acceptable units delivered multiplied by the per unit price and shall be made within sixty (60) days of the acceptance of the units.

B. BASIS FOR DETERMINING PRICES

It is expressly understood and agreed that:

3. Contract Time Proposal

If this Contract/Proposal is accepted, Bidder proposes, and agrees, that Bidder shall commence the Work within 10 days following Owner's acceptance of this Contract/Proposal (the "Commencement Date"). If this Contract/Proposal is accepted, Bidder proposes, and agrees, that Bidder shall perform the Work diligently and continuously and shall complete the Work not later than 120 calendar days following the Commencement Date.

1. All prices stated in the Schedule of Prices are firm and shall not be subject to escalation or change;
2. Owner is not subject to state or local sales, use, and excise taxes, that no such taxes are included in the Schedule of Prices, and that all claim or right to claim any additional compensation by reason of the payment of any such tax is hereby waived and released;
3. All other applicable federal, state, and local taxes of every kind and nature applicable to the Work are included in the Schedule of Prices;
4. The approximate quantities set forth in the Schedule of Prices for each Unit Price Item are Owner's estimate only, that Owner reserves the right to increase or decrease such quantities and that all claim or right to dispute or complain of any such estimated quantity, or to assert that there was any misunderstanding in regard to the nature or amount of any Unit Price Item to be provided or performed, is hereby waived and released; and
5. Any items of Work not specifically listed or referred to in the Schedule of Prices, or not specifically included for payment under any Unit Price Item, shall be deemed incidental to the Contract Price, shall not be measured for payment, and shall not be paid for separately.

4. Financial Assurance

C. VALUE OF WORK

It is expressly understood and agreed that the value of the Work shall be determined as follows:

- A. Bid Security. Each Bidder's Proposal shall be accompanied by a security deposit of at least ten percent of the Bidder's Price Proposal in the form of (1) a Cashier's Check or Certified Check drawn on a solvent bank insured by the Federal Deposit Insurance Corporation and payable without condition to Owner or (2) a Bid Bond in a form satisfactory to Owner from a surety company licensed to do business in the State of Illinois with a general rating of A Minus and a financial size category of Class X or better in Best's Insurance Guide.
- B. Bonds. If this Contract/Proposal is accepted, Bidder proposes, and agrees, that Bidder shall provide a Performance Bond and a Labor and Material Payment Bond, on forms provided by, or otherwise acceptable to, Owner, from a surety company acceptable to Owner, each in the penal sum of the Contract Price, within 10 days following Owner's acceptance of this Contract/Proposal.
- C. Insurance. If this Contract/Proposal is accepted, Bidder proposes, and agrees, that Bidder will procure and maintain such insurance as will cover and include the entire obligation assumed by Bidder under the Contract Documents, as well as public liability insurance, including contractual liability, contractors liability and protective liability, automobile liability insurance, including non-owned automobile liability, and Workmen's Compensation and employer's liability insurance as will adequately protect Owner, the Work, and other property and persons against all damages, liability claims, losses and expenses (including attorney's fees) which may arise, or be alleged to

1. The value of Work shall be determined by Owner on the basis of the actual number of Unit Price Items acceptable to the Owner multiplied by the

Resolution No. R-22-19

have arisen, out of or in connection with Bidder's performance of, or failure to perform, the Work or any part thereof.

D. Indemnification. If this Contract/Proposal is accepted, Bidder proposes, and agrees, that Bidder shall indemnify, save harmless, and defend Owner against all damages, liability, claims, losses, and expenses (including attorneys' fees) that may arise, or be alleged to have arisen, out of or in connection with Bidder's performance of, or failure to perform, the Work or any part thereof, or any failure to meet the representations and warranties set forth in Section 6 of this Contract/Proposal.

D. Penalties. If this Contract/Proposal is accepted, Bidder proposes, and agrees, that Bidder shall be solely liable for any fines or civil penalties that are imposed by any governmental or quasi-governmental agency or body that may arise, or be alleged to have arisen, out of or in connection with Bidder's performance of, or failure to perform, the Work or any part thereof.

5. Firm Proposal

All prices and other terms stated in this Contract/Proposal are firm and shall not be subject to withdrawal, escalation, or change provided Owner accepts this Contract/Proposal within 60 days after the date this sealed Contract/Proposal is opened.

6. Bidder's Representations and Warranties

In order to induce Owner to accept this Contract/Proposal, Bidder hereby represents and warrants as follows:

A. The Work. The Work, and all of its components, shall be of merchantable quality; shall be free from any latent or patent defects and flaws in workmanship, materials, and design; shall strictly conform to the requirements of this Contract/Proposal and these Contract Documents, including, without limitation, the performance standards set forth in Section 1B of this Contract/Proposal; and shall be fit, sufficient, and suitable for the purposes expressed in, or reasonably inferred from, this Contract/Proposal and these Contract Documents and the warranties expressed herein shall be in addition to any other warranties expressed or implied by law, which are hereby reserved unto Owner. Bidder shall, promptly and without charge, correct any failure to fulfill the above warranty at any time within two years after final payment or such longer period as may be prescribed in the performance standards set forth in Section 1B of this Contract/Proposal, the Contract Documents or by law. The above warranty shall be extended automatically to cover all repaired and replacement parts and labor provided or performed under such warranty and Bidder's obligation to correct Work shall be extended for a period of two years from the date of such repair or replacement. The time period established in this Section 6A relates only to the specific obligation of Bidder to correct Work and shall not be construed to establish a period of limitation with respect to other obligations that Bidder has under this Contract/Proposal and the Contract Documents.

B. Compliance with Laws. The Work, and all of its components, shall be provided, performed, and completed in compliance with, and Bidder agrees to be bound by, all applicable federal, state, and local laws, orders, rules, and regulations, as they may be modified or amended from time to time; any statutes requiring preference to laborers of specified classes; the Illinois Steel Products Procurement Act, 30 ILCS 565/1 et seq.; any statutes prohibiting discrimination because of, or requiring affirmative action based on, race, creed, color, national origin, age, sex, or other prohibited classification; and any statutes regarding safety or the performance of the Work.

This Contract calls for the construction of a "public work," within the meaning of the Illinois Prevailing Wage Act, 820 ILCS 130/01 et seq. ("the Act"). The Act requires contractors and subcontractors to pay laborers, workers and mechanics performing services on public works projects no less than the current "prevailing rate of wages" (hourly cash wages plus amount for fringe benefits) in the county where the work is performed. The Department publishes the prevailing wage rates on its website at <http://labor.illinois.gov/>. The Department revises the prevailing wage rates and the Bidder has an obligation to check the Department's website for revisions to prevailing wage rates. For more information regarding current prevailing wage rates, please refer to the Illinois Department of Labor's website. All contractors and subcontractors rendering services under this Contract must comply with all requirements of the Act, *including but not limited to*, all wage requirements and notice and record keeping duties.

C. Not Barred. Bidder is not barred by law from contracting with Owner or with any other unit of state or local government for any reason, including without limitation as a result of (i) a violation of either Section 33E-3 or Section 33E-4 of Article 33 of the Criminal Code of 1961, 720 ILCS 5/33E-1 et seq.; or (ii) a violation of the USA Patriot Act of 2001, 107 Public Law 56 (October 26, 2001) (the "Patriot Act") or other statutes, orders, rules, and regulations of the United States government and its various executive departments, agencies and offices related to the subject matter of the Patriot Act, including, but not limited to, Executive Order 13224 effective September 24, 2001. Bidder is not acting, directly or indirectly, for or on behalf of any person, group, entity or nation named by the United States Treasury Department as a Specially Designated National and Blocked Person, or for or on behalf of any person, group, entity or nation designated in Presidential Executive Order 13224 as a person who commits, threatens to commit, or supports terrorism; and Bidder is not engaged in this transaction directly or indirectly on behalf of, or facilitating this transaction directly or indirectly on behalf of, any such person, group, entity or nation.

D. Qualified. Bidder has the requisite experience, ability, capital, facilities, plant, organization, and staff to enable Bidder to perform the Work successfully and promptly and to commence and complete the Work within the Contract Price and Contract Time Proposals set forth above.

In submitting this Contract/Proposal, Bidder acknowledges and agrees that:

7. Acknowledgments

Resolution No. R-22-19

A. Reliance. Owner is relying on all warranties, representations, and statements made by Bidder in this Contract/Proposal and related Contract Documents.

B. Reservation of Rights. Owner reserves the right to reject any and all proposals, reserves the right to reject the low price proposal, and reserves such other rights as are set forth in the Instructions to Bidders.

C. Acceptance. If this Contract/Proposal is accepted, Bidder shall be bound by each and every term, condition, or provision contained in this Contract/Proposal and the remaining Contract Documents including those terms contained in Owner's written notification of Acceptance attached hereto as Attachment E.

D. Remedies. In the event of a breach or violation of any term or condition of this Contract/Proposal or any of the other Contract Documents, Owner shall have recourse through any remedy available at law or in equity and all such remedies shall be cumulative. .

E. No Waiver. No examination, inspection, investigation, test, measurement, review, determination, decision, certificate, or approval by Owner, whether before or after Owner's acceptance of this Contract/Proposal; nor any information or data supplied by Owner, whether before or after Owner's acceptance of this Contract/Proposal; nor any order by Owner for the payment of money; nor any payment for, or use, possession, or acceptance of, the whole or any part of the Work by Owner; nor any extension of time granted by Owner; nor any delay by Owner in exercising any right under this Contract/Proposal or other Contract Document; nor any other act or omission of Owner shall constitute or be deemed to be an acceptance of any defective, damaged, or nonconforming Work, nor operate to waive or otherwise diminish the effect of any representation or warranty made by Bidder; or of any requirement or provision of this Contract/Proposal or other Contract Document; or of any remedy, power, or right of Owner.

F. Severability. The provisions of this Contract/Proposal together with the other Contract Documents shall be interpreted when possible to sustain their legality and enforceability as a whole. In the event any provision of this Contract/Proposal together with the other Contract Documents shall be held invalid, illegal, or unenforceable by a court of competent jurisdiction, in whole or in part, neither the validity of the remaining part of such provision, nor the validity of any other provisions of this Contract/Proposal or other Contract Documents shall be in any way affected thereby.

G. Amendments. No modification, addition, deletion, revision, alteration, or other change to this Contract/Proposal or other Contract Documents shall be effective unless and until such change is reduced to writing and executed and delivered by Owner and Bidder.

H. Assignment. Neither this Contract/Proposal or other Contract Documents, nor any interest herein, shall be assigned or subcontracted, in whole or in part, by Bidder except upon the prior written consent of Owner.

I. Governing Law. This Contract/Proposal and other Contract Documents and the rights of the parties under this Contract/Proposal and other Contract Documents shall be interpreted according to the internal laws, but not the conflict of law rules, of the State of Illinois. Every provision of law required by law to be inserted into this Contract/Proposal or other Contract Documents shall be deemed to be inserted herein.

PROPOSAL

Bidder's Status: () _____ Corporation () _____ Partnership () Individual Proprietor
(State) (State)

Bidder's Name: _____

Doing Business As (if different): _____

Signature of Bidder or Authorized Agent: _____

(corporate seal) Printed Name: _____
(if corporation)

Title/Position: _____

DATED this _____ day of _____, 2019

Bidder's Business Address: _____

Bidder's Business Telephone: _____ Facsimile: _____

If a Corporation or Partnership, list all Officers or Partners:

NAME	TITLE	ADDRESS

Resolution No. R-22-19

Attachment A

SCHEDULE OF PRICES

[TO BE DEVELOPED]

Attachment B

SCOPE OF WORK

[TO BE DEVELOPED]

Attachment C

SPECIFICATIONS

[TO BE DEVELOPED]

Attachment D

**DRAWINGS
[TO BE DEVELOPED]**

Attachment E

ACCEPTANCE

The Contract/Proposal attached hereto and by this reference incorporated herein and made a part hereof is hereby accepted by the order of the DuPage Water Commission ("Owner") this _____ day of _____, 2019.

This Acceptance, together with the Contract/Proposal attached hereto, constitutes the entire and only agreement between the parties relating to the accomplishment of the Work and the compensation therefor and supersedes and merges any other prior or contemporaneous discussions, agreements, or understandings, whether written or oral, and shall prevail over any contradictory or inconsistent terms or conditions contained in any purchase order, acceptance, acknowledgement, invoice, or other standard form used by the parties in the performance of the Contract/Proposal. Any such contradictory or inconsistent terms or conditions shall be deemed objected to by Owner without further notice of objection and shall be of no effect nor in any circumstances binding upon Owner unless accepted by Owner in a written document plainly labeled "Amendment to Contract/Proposal." Acceptance or rejection by Owner of any such contradictory or inconsistent terms or conditions shall not constitute acceptance of any other contradictory or inconsistent terms or conditions.

DUPAGE WATER COMMISSION

By: _____
John F. Spatz, Jr.
General Manager

REQUEST FOR BOARD ACTION

AGENDA SECTION	Engineering & Construction Committee	ORIGINATING DEPARTMENT	Facilities Construction
ITEM	<p>A Resolution Approving and Ratifying Certain Task Orders Under a Master Contract with Greeley and Hansen</p> <p>Resolution No. R-23-19</p>	<p>APPROVAL</p> 	
<p>Account No.: 01-60-711500 - \$8,000</p> <p>On November 17, 2017, the Commission approved R-39-17, Task Order No. 1, with Greeley and Hansen for professional design services, bidding services, project management services and construction services for the Bartlett Metering Station at a cost not-to-exceed \$107,000.00.</p> <p>During the Construction Services Phase, several incomplete Contract Submittals needed additional reviews by the Engineer over and above the predetermined limits of the Task Order. However, the Contract with JJ Henderson (the Contractor) includes provision to remunerate the Commission for Excess Engineering. The Excess Engineering deduction will offset a good portion of the additional cost of this Task Order Amendment.</p> <p>In addition, Task Order No. 1 did not include the development of Record Drawings and development of Operation and Maintenance Manuals. These documents are essential to future maintenance of Commission assets.</p> <p>Resolution No. R-23-19 would approve the First Amendment to Task Order No.1 to the Master Contract with Greeley and Hansen for an additional \$8,000.00, making the Total Cost not-to exceed \$115,000.00.</p> <p>In accordance with the Water Supply and Purchase Agreement, all engineering expenses related to the Bartlett Connection Facilities shall be remunerated by the Village of Bartlett.</p>			
<p>MOTION: To adopt Resolution No. R-23-19.</p>			

DuPAGE WATER COMMISSION

RESOLUTION NO. R-23-19

A RESOLUTION APPROVING A FIRST AMENDMENT TO
TASK ORDER NO. 1 UNDER A MASTER CONTRACT
WITH GREELEY AND HANSEN

WHEREAS, the DuPage Water Commission (the "Commission") entered into a contract with Greeley and Hansen (the "Consultant") to provide, from time to time, professional engineering services in connection with various projects of the Commission (the "Master Contract"); and

WHEREAS, the Master Contract sets forth the terms and conditions pursuant to which the Commission will obtain from time to time, and the Consultant will provide from time to time, professional engineering services for such discrete projects as are delineated and described in Task Orders to be approved by the Commission and the Consultant; and

WHEREAS, pursuant to Resolution No. R-39-17, the Commission approved Task Order No. 1 to the Master Contract for Professional Engineering Services for the DuPage Water Commission; and

WHEREAS, the Commission and Consultant desire to amend Task Order No. 1 to the Master Contract to add costs incurred with Contract Submittal review, Record Drawing and Operation and Maintenance Manual development, and to increase the not-to-exceed cost of the services, the Board of Commissioners of the DuPage Water Commission hereby finding and determining, based upon the representations of Staff and Consultant that the circumstances said to necessitate the changes were not reasonably foreseeable at the time Task Order No. 1 was signed, the changes are germane to the Task Order as signed, and/or the changes are in the best interest of the DuPage Water Commission and authorized by law; and

WHEREAS, the Consultant has approved the First Amendment to Task Order No. 1 attached hereto and by this reference incorporated herein and made a part hereof as Exhibit 1;

NOW, THEREFORE, BE IT RESOLVED by the Board of Commissioners of the DuPage Water Commission as follows:

SECTION ONE: The foregoing recitals are incorporated herein and made a part hereof as findings of the Board of Commissioners of the DuPage Water Commission.

SECTION TWO: The First Amendment to Task Order No. 1 attached hereto as Exhibit 1 shall be and hereby is approved.

SECTION THREE: This Resolution shall constitute the written determination required by Section 33E-9 of Article 33E of the Criminal Code of 1961 and shall be in full force and effect from and after its adoption.

AYES:

NAYS:

ABSENT:

ADOPTED THIS _____ DAY OF _____, 2019.

Chairman

ATTEST:

Clerk

EXHIBIT 1

**FIRST AMENDMENT TO
TASK ORDER NO. 1**

In accordance with Section 1.1 of the Master Contract between the DuPage Water Commission (“Owner”) and Greeley and Hansen (“Consultant”), for Professional Engineering Services dated June 19, 2013 (the “Contract”), Owner and Consultant agree to amend, effective July 20, 2019, Task Order No. 1 to the Village of Bartlett Unit System to the Commission’s Waterworks System (“The Connection Facilities”) for the DuPage Water Commission (Task Order No. 1) as follows:

1. Contract Price:

Section 8, entitled “Contract Price,” of Task Order No. 5 shall be amended in its entirety so that said Section 8 shall hereafter be and read as follows:

“8. Contract Price:

For providing, performing, and completing each phase of Services, an amount equal to Consultant’s Direct Labor Costs times the following factor set forth opposite each such phase, plus an amount equal to the actual costs of all Reimbursable Expenses, but not to exceed, in each phase of Services, the following not to exceed amount set forth opposite each such phase except as adjusted by a Change Order issued pursuant to Section 2.1 of the Contract:

<u>Phase</u>	<u>Direct Labor Cost Factor</u>	<u>Not to Exceed</u>
Preliminary Design	3.15	\$35,000
Final Design	3.15	\$28,000
Bidding	3.15	\$3,000
<i>Construction</i>	3.15	<u><i>\$49,000</i></u>
<i>Total (All Phases)</i>		<u><i>\$115,000</i></u>

Notwithstanding the foregoing, the total Contract Price shall be increased by \$8,000.00 to a total not to exceed sum of \$115,000.00. The contact price maybe adjusted by a Change Order issued pursuant to Section 2.1 of the Contract.”

In all other respects, Task Order No. 1 to the Contract shall remain in full force and effect, and Task Order No. 1 to the Contract shall be binding on both parties as hereinabove amended.

DUPAGE WATER COMMISSION

BY:

John F. Spatz
General Manager

AECOM TECHNICAL SERVICES, INC.

BY:

Joe Dinkel, P.E.
Principle
Manager, MEPIC Group

DATE: August 8, 2019

REQUEST FOR BOARD ACTION

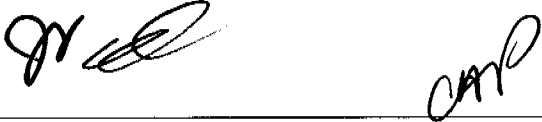
AGENDA SECTION	Engineering & Construction Committee	ORIGINATING DEPARTMENT	Pipeline						
ITEM	A Resolution Approving and Ratifying Certain Work Authorization Orders Under Quick Response Contract QR-11/17 at the August 15, 2019, DuPage Water Commission Meeting Resolution No. R-24-19	APPROVAL							
Account Number: 01-60-663100									
<p>The Commission entered into certain agreements dated June 30, 2017 with John Neri Construction Co., Inc. and Rossi Contractors, Inc. for quick response construction work, as needed, through the issuance of Work Authorization Orders. Resolution No. R-24-19 would approve the following Work Authorization Order under the Quick Response Contracts.</p> <p>Work Authorization Order No. 011 to John Neri Construction Co., Inc. This work authorization is for the work necessary to remove and replace wooden timbers that are supporting a replacement section of 90" steel pipe stored on the Commission's Material Storage Pad.</p> <p>The wooden timbers supporting a certain section of 90" inch diameter pipe are no longer structurally sound. Staff solicited estimates from both of its QR-11/17 Contractors for the work involved to lift the section of pipe, remove the unsuitable supports and replace them with new timber supports. The results of those estimates are listed in the table below.</p>									
<table border="1"><thead><tr><th>Contractor</th><th>Estimate</th></tr></thead><tbody><tr><td>John Neri Construction Co., Inc.</td><td>\$3,100.00</td></tr><tr><td>Rossi Contractors Inc.</td><td>\$4,359.33</td></tr></tbody></table>				Contractor	Estimate	John Neri Construction Co., Inc.	\$3,100.00	Rossi Contractors Inc.	\$4,359.33
Contractor	Estimate								
John Neri Construction Co., Inc.	\$3,100.00								
Rossi Contractors Inc.	\$4,359.33								
<p>Approval of Resolution R-24-19 would approve Work Authorization Order Number 11 to John Neri Construction Co., Inc. for the work necessary to remove and replace timber pipe supports on a section of 90" diameter water main.</p>									
MOTION: To adopt Resolution No. R-24-19									

DUPAGE WATER COMMISSION

RESOLUTION NO. R- 24-19

A RESOLUTION APPROVING AND RATIFYING
CERTAIN WORK AUTHORIZATION ORDERS
UNDER QUICK RESPONSE CONTRACT QR-11/17 AT THE
AUGUST 15, 2019 DUPAGE WATER COMMISSION MEETING

WHEREAS, the DuPage Water Commission (the "Commission") entered into certain agreements dated June 30, 2017, with John Neri Construction Co. and Rossi Contractors, Inc. for quick response construction work related to the Commission's Waterworks System (said agreements being hereinafter collectively referred to as "Contract QR-11/17"); and

WHEREAS, Contract QR-11/17 is designed to allow the Commission to direct one or more or all the quick response contractors to perform quick response construction work, including without limitation construction, alteration, and repair related to the Commission's Waterworks System, as needed through the issuance of Work Authorization Orders; and

WHEREAS, the need for quick response construction work could not have been reasonably foreseen at the time the contracts were signed;

NOW, THEREFORE, BE IT RESOLVED by the Board of Commissioners of the DuPage Water Commission as follows:

SECTION ONE: The foregoing recitals are by this reference incorporated herein and made a part hereof as findings of the Board of Commissioners of the DuPage Water Commission.

SECTION TWO: The Work Authorization Orders attached hereto and by this reference incorporated herein and made a part hereof as Exhibit 1 shall be and hereby are

approved and, if already issued, ratified because the Board of Commissioners of the DuPage Water Commission has determined, based upon the representations of staff, that the circumstances said to necessitate the Work Authorization Orders were not reasonably foreseeable at the time the contracts were signed, the Work Authorization Orders are germane to the original contracts as signed, and/or the Work Authorization Orders are in the best interest of the DuPage Water Commission and authorized by law.

SECTION THREE: This Resolution shall constitute the written determination required by Section 33E-9 of the Criminal Code of 1961 and shall be in full force and effect from and after its adoption.

AYES:

NAYS:

ABSENT:

ADOPTED this ____ day of _____, 2019.

Chairman

ATTEST:

Clerk

Board/Resolutions/R-24-19.docx

Exhibit 1

WORK AUTHORIZATION ORDER

SHEET 1 OF 2

CONTRACT QR-11/17: QUICK RESPONSE CONTRACT

WORK AUTHORIZATION ORDER NO.: 011

LOCATION:

DuPage Water Commission's Material Storage Pad.

CONTRACTOR:

John Neri Construction Co., Inc.

DESCRIPTION OF WORK:

Using a suitably rated crane, and in accordance with the pipe manufacture recommendations, lift a section of 90" diameter steel water main to remove the existing timber supports and replace them with new. The quantity, length and cross-sectional dimensions of the new supports shall, at a minimum, match the existing supports in all respects.

REASON FOR WORK:

This work is necessary to remove and replace timber pipe supports on a section of 90" diameter water main.

MINIMUM RESPONSE TIME:

N/A

**COMMISSION-SUPPLIED MATERIALS, EQUIPMENT
AND SUPPLIES TO BE INCORPORATED INTO THE WORK:**

N/A

THE WORK ORDERED PURSUANT TO THIS WORK AUTHORIZATION ORDER

IS IS NOT PRIORITY WORK

SUPPLEMENTARY NOTIFICATION OF POTENTIALLY HAZARDOUS CONDITIONS:

N/A

SUBMITTALS REQUESTED:

N/A

SUPPLEMENTARY CONTRACT SPECIFICATIONS AND DRAWINGS:

N/A

DUPAGE WATER COMMISSION

By: _____
Signature of Authorized
Representative





DATE: _____

CONTRACTOR RECEIPT ACKNOWLEDGED AND DESIGNATION OF SAFETY REPRESENTATIVE:

By: _____ Safety Rep: _____
Signature of Authorized Name and 24-Hr Phone No.
Representative

DATE: _____

REQUEST FOR BOARD ACTION

AGENDA SECTION Engineering & Construction Committee	ORIGINATING DEPARTMENT Instrumentation/ Remote Facilities
ITEM A Resolution Approving and Ratifying Certain Work Authorization Orders Under Quick Response Electrical Contract QRE-8/17 at the August 15, 2019, DuPage Water Commission Meeting Resolution No. R-25-19	APPROVAL    

Account Numbers: 01-60-663300 (Estimated Cost \$11,221.00)

The Commission entered into certain agreements dated December 29, 2017, with McWilliams Electric Co. Inc. and with Volt Electric, Inc. for quick response electrical work as needed through the issuance of Work Authorization Orders. Resolution No. R-25-19 would approve the following Work Authorization Orders under the Quick Response Electrical Contracts:

Work Authorization Order No. 011: This work authorization is to Volt Electric, Inc., to relocate the SCADA communication antenna to the top of Willowbrook's standpipe. For several years the communications have been getting worse at this location do to the position and height of the antenna on the side of the standpipe. By moving it to the top of the 150' standpipe there will be no more communication issues. Willowbrook has agreed to allow us to put the antenna on top of the standpipe.

Proposals were received from both QRE-8/17 electrical contractors and their estimates are listed below.

QRE Contractor	Estimate
Volt Electric, Inc.	\$11,221.00
McWilliams Electric Co., Inc.	\$11,940.00

The work will be billed at time and material, estimated cost of \$11,221.00.

MOTION: To adopt Resolution No. R-25-19.

DUPAGE WATER COMMISSION

RESOLUTION NO. R-25-19

A RESOLUTION APPROVING AND RATIFYING
CERTAIN WORK AUTHORIZATION ORDERS
UNDER QUICK RESPONSE ELECTRICAL CONTRACT QRE-8/17
AT THE AUGUST 15, 2019, DUPAGE WATER COMMISSION MEETING

WHEREAS, the DuPage Water Commission (the "Commission") entered into certain agreements dated December 29, 2017, with McWilliams Electric Co. Inc. and with Volt Electric, Inc., for quick response electrical work related to the Commission's Waterworks System (said agreements being hereinafter collectively referred to as "Contract QRE-8/17"); and

WHEREAS, Contract QRE-8/17 is designed to allow the Commission to direct one or more or all of the quick response electrical contractors to perform emergency electrical work, including without limitation electrical work that the Commission is unable to perform through its own personnel and with its own equipment, as needed through the issuance of Work Authorization Orders;

NOW, THEREFORE, BE IT RESOLVED by the Board of Commissioners of the DuPage Water Commission as follows:

SECTION ONE: The foregoing recitals are by this reference incorporated herein and made a part hereof as findings of the Board of Commissioners of the DuPage Water Commission.

SECTION TWO: The Work Authorization Orders attached hereto and by this reference incorporated herein and made a part hereof as Exhibit 1 shall be and hereby are approved and, if already issued, ratified because the Board of Commissioners of the

Resolution No. R-25-19

DuPage Water Commission has determined, based upon the representations of staff, that the circumstances said to necessitate the Work Authorization Orders were not reasonably foreseeable at the time the contracts were signed, the Work Authorization Orders are germane to the original contracts as signed, and/or the Work Authorization Orders are in the best interest of the DuPage Water Commission and authorized by law.

SECTION THREE: This Resolution shall constitute the written determination required by Section 33E-9 of the Criminal Code of 1961 and shall be in full force and effect from and after its adoption.

AYES:

NAYS:

ABSENT:

ADOPTED this ____ day of _____, 2019

Chairman

ATTEST:

Clerk

Exhibit 1

WORK AUTHORIZATION ORDER

SHEET 1 OF 2

CONTRACT QRE-8/17: QUICK RESPONSE ELECTRICAL CONTRACT

PROJECT: QRE-8.011

LOCATIONS:

MS22A Willowbrook Public Works, 75th Street, Willowbrook, IL

CONTRACTOR:

Volt Electric, Inc.

DESCRIPTION OF WORK:

Install new 7/8" Heliac antenna cable from meter station 22A to top of Willowbrook's Standpipe. Mount new antenna mast with antenna and connect new cable. Use existing conduit path from meter station under driveway to West side of Standpipe. Add handhole and conduit to continue path to South Pilaster with ladder. Conduit at pilaster shall terminate at side of pilaster wall. Antenna cable to be one continuous piece, no splicing. The cable is to run up inside of Pilaster on left side of ladder secured about every 6'. A hole may have to be made at top of pilaster for cable to get up and out to platform. Route cable along guardrail securing about every 6' to East side of standpipe. Mount a 6' L x 2" aluminum pipe to the guardrail for the antenna mast. Mount antenna to mast so it is about 5' off the platform. Use a flexible antenna cable about 6' long to connect the 7/8" heliac cable to the antenna. Add proper ground kit on cable near antenna and at base of standpipe. Work with DWC staff to test and aim antenna.

Approximate cable length: Meter station to pilaster about 150', Standpipe height about 153.5', ¼ away around top of standpipe is about 52.5' for a total cable length of about 356'. Use these dimensions for the estimate. However, dimensions need to be verified before ordering cable. Provide all materials for a complete solution.

REASON FOR WORK:

Chronic communication issues for years. Moving antenna to top of standpipe will solve problem.

MINIMUM RESPONSE TIME:

None

COMMISSION-SUPPLIED MATERIALS, EQUIPMENT AND SUPPLIES TO BE INCORPORATED INTO THE WORK:

None

THE WORK ORDERED PURSUANT TO THIS WORK AUTHORIZATION ORDER

IS IS NOT PRIORITY EMERGENCY WORK

SHEET 2 OF 2

SUBMITTALS REQUESTED:

None

SUPPLEMENTARY NOTIFICATION OF POTENTIALLY HAZARDOUS CONDITIONS:

None

SUPPLEMENTARY CONTRACT SPECIFICATIONS AND DRAWINGS:

Drawing of standpipe details and site plan.

DUPAGE WATER COMMISSION

By:

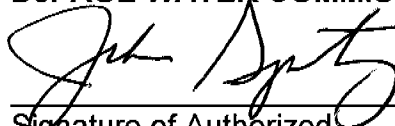

Signature of Authorized Representative

DATE:

7/11/19

CONTRACTOR RECEIPT ACKNOWLEDGED AND DESIGNATION OF SAFETY REPRESENTATIVE:

By:

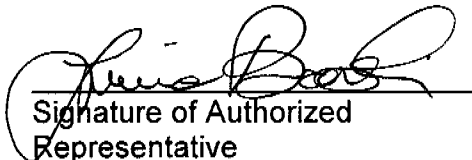

Signature of Authorized Representative

Safety Rep:

Fred Kala
Name and 24-Hr Phone No.

DATE:

7/16/19

REQUEST FOR BOARD ACTION

AGENDA SECTION	Omnibus Vote Requiring Super-Majority or Special Majority Vote	ORIGINATING DEPARTMENT	Operations
ITEM	<p>A Resolution Suspending Purchasing Procedures and authorizing the General Manager to purchase critical spare medium voltage breakers and power transformer at an estimated cost of \$68,000.00 from Industrial Electric Manufacturing.</p> <p>Resolution No. R-26-19</p>	<p>APPROVAL</p> <p>MW JY</p> <p style="text-align: right;">CAMP</p>	
<p>Account Number: 01-60-771200</p> <p>The DuPage Pumping Station utilizes General Electric medium voltage electrical breakers built by Industrial Electric Manufacturing (IEM) for its two main power breakers including tie breakers and generator breakers. IEM was responsible for the engineering, design, manufacturing, and testing of the Commission's existing switchgear related to PSD 7 Electrical Generation Project.</p> <p>IEM provides customer service, support and warranty service associated for all IEM switchgear located at the DuPage Pumping Station. IEM recommends that all parts and service requests are to be handled by IEM being that they are responsible for the system integrity.</p> <p>The two critical spare breakers will be delivered as plug and play ready, no additional engineering or modifications to the breakers will be required.</p> <p>Resolution No. R-26-19 would suspend purchasing procedures and authorize the General Manager to purchase two (2) critical spare medium voltage breakers and one (1) critical power transformer for the Commission's Electrical Switchgear system at an estimated cost of \$68,000.00 from Industrial Electric Manufacturing.</p> <p>This purchase is being undertaken as a direct Engineer's recommendation in the 2014/2015 Condition Assessment and was included in the FY-19/20 Management Budget as a Capital Improvement Project.</p>			
<p>MOTION: To approve Resolution No. R-26-19.</p>			

DUPAGE WATER COMMISSION

RESOLUTION NO. R-26-19

A RESOLUTION TO SUSPEND PURCHASING PROCEDURES AND AUTHORIZE
THE GENERAL MANAGER TO PURCHASE
SPARE MEDIUM VOLTAGE BREAKERS AND POWER TRANSFORMER

WHEREAS, the DuPage Water Commission's pumping system utilizes General Electric medium voltage electrical breaker built by Industrial Electric Manufacturing; and

WHEREAS, Industrial Electric Manufacturing was responsible for the engineering, design, manufacturing, and testing of the Commission's existing switchgear related to PSD 7 Electrical Generation Project.

WHEREAS, Industrial Electric Manufacturing provides customer service, support and warranty service associated for all IEM switchgear located at DWC; and

WHEREAS, the Board of Commissioners of the DuPage Water Commission believes it is in the best interest of the Commission to suspend purchasing procedures and authorize the General Manager to purchase critical spare medium voltage breakers and power transformer at an estimated cost of \$68,000.00 from Industrial Electric Manufacturing;

NOW, THEREFORE, BE IT RESOLVED by the Board of Commissioners of the DuPage Water Commission as follows:

SECTION ONE: The foregoing recitals are incorporated herein and made a part hereof as findings of the Board of Commissioners of the DuPage Water Commission as if fully set forth.

SECTION TWO: That the purchasing procedures contained in Article VIII of the Commission By-Laws are hereby suspended as provided by Article XII, Section 3 of the Commission By-Laws, and that the General Manager is here by granted the authority to purchase two spare medium voltage breakers and one power transformer at an estimated cost of \$68,000.00 from Industrial Electric Manufacturing without further act.

SECTION THREE: This Resolution shall be in full force and effect from and after its adoption.

AYES:

NAYS:

ABSENT:

ADOPTED THIS _____ DAY OF _____, 2019.

Chairman

ATTEST:

Clerk

DATE: August 6, 2019

REQUEST FOR BOARD ACTION

AGENDA SECTION	Engineering & Construction Committee	ORIGINATING DEPARTMENT	Instrumentation/ Remote Facilities
ITEM	A Resolution Approving and Ratifying Certain Work Authorization Orders Under Quick Response Electrical Contract QRE-8/17 at the August 15, 2019, DuPage Water Commission Meeting Resolution No. R-28-19	APPROVAL	
Account Numbers: 01-60-663300 (Estimated Cost \$15,780.00)			
<p>The Commission entered into certain agreements dated December 29, 2017, with McWilliams Electric Co. Inc. and with Volt Electric, Inc. for quick response electrical work as needed through the issuance of Work Authorization Orders. Resolution No. R-28-19 would approve the following Work Authorization Orders under the Quick Response Electrical Contracts:</p> <p>Over the past several months Field Maintenance Technicians have identified about 30 electrical problems at various remote facilities that require an electrician to rectify. The locations were sorted by North and South sides of the County and divided between the two Quick Response Electrical (QRE) contractors. Each contractor provided an estimate for the work that was assigned to them.</p> <p>Work Authorization Order No. 012: This work authorization is to Volt Electric, Inc., to correct various electrical problems at various remote facilities on the Southern half of the County. Many of the problems are replacing circuit breakers other problems are broken conduits, relocating a disconnect switch for better access, and troubleshooting/correcting a circuit for an electric heater.</p> <p>The work will be billed at time and material, estimated cost of \$6,240.00.</p> <p>Work Authorization Order No. 013: This work authorization is to McWilliams Electric Co., Inc., to correct various electrical problems at various remote facilities on the Northern half of the County. Many of the problems are replacing circuit breakers other problems are broken conduits and installing a new J-Box.</p> <p>The work will be billed at time and material, estimated cost of \$9,540.00.</p>			
MOTION: To adopt Resolution No. R-28-19.			

DUPAGE WATER COMMISSION

RESOLUTION NO. R-28-19

A RESOLUTION APPROVING AND RATIFYING
CERTAIN WORK AUTHORIZATION ORDERS
UNDER QUICK RESPONSE ELECTRICAL CONTRACT QRE-8/17
AT THE AUGUST 15, 2019, DUPAGE WATER COMMISSION MEETING

WHEREAS, the DuPage Water Commission (the "Commission") entered into certain agreements dated December 29, 2017, with McWilliams Electric Co. Inc. and with Volt Electric, Inc., for quick response electrical work related to the Commission's Waterworks System (said agreements being hereinafter collectively referred to as "Contract QRE-8/17"); and

WHEREAS, Contract QRE-8/17 is designed to allow the Commission to direct one or more or all of the quick response electrical contractors to perform emergency electrical work, including without limitation electrical work that the Commission is unable to perform through its own personnel and with its own equipment, as needed through the issuance of Work Authorization Orders;

NOW, THEREFORE, BE IT RESOLVED by the Board of Commissioners of the DuPage Water Commission as follows:

SECTION ONE: The foregoing recitals are by this reference incorporated herein and made a part hereof as findings of the Board of Commissioners of the DuPage Water Commission.

SECTION TWO: The Work Authorization Orders attached hereto and by this reference incorporated herein and made a part hereof as Exhibit 1 shall be and hereby are approved and, if already issued, ratified because the Board of Commissioners of the

Resolution No. R-28-19

DuPage Water Commission has determined, based upon the representations of staff, that the circumstances said to necessitate the Work Authorization Orders were not reasonably foreseeable at the time the contracts were signed, the Work Authorization Orders are germane to the original contracts as signed, and/or the Work Authorization Orders are in the best interest of the DuPage Water Commission and authorized by law.

SECTION THREE: This Resolution shall constitute the written determination required by Section 33E-9 of the Criminal Code of 1961 and shall be in full force and effect from and after its adoption.

AYES:

NAYS:

ABSENT:

ADOPTED this ____ day of _____, 2019

Chairman

ATTEST:

Clerk

Exhibit 1

WORK AUTHORIZATION ORDER

SHEET 1 OF 2

CONTRACT QRE-8/17: QUICK RESPONSE ELECTRICAL CONTRACT

PROJECT: QRE-8.012

LOCATIONS:

Various locations, see attached list

CONTRACTOR:

Volt Electric, Inc.

DESCRIPTION OF WORK:

MS6A, 7A, 7B/8F, 8A, 8B, 8C, 8E, 15A, 15C, 24B: Test all GFCI breakers and replace as needed. All 20A breakers, some are Dual Breakers

MS8C: Replace 20A breaker 12 with 20A GFCI breaker

MS8E: Troubleshoot and repair main heater not working, bad breaker or wiring?

MS17A: Correct misaligned row of breakers in LP and replace 20A breaker with GFCI

MS17B: Remove old SPD from Heating Panel and plug hole.

MS24A: Correct broken conduit in lower level from LP breaker 7.

TS1: Relocate Southwest heater disconnect and thermostat from behind pipe, so it is accessible.

While covers are off breaker panels: clean in side of panel, check all connections, and inspect for any code violations. When at meter stations with two panels (LP & HP) open both panels to inspect.

REASON FOR WORK:

Correct electrical problems found by DWC staff at various remote facilities.

MINIMUM RESPONSE TIME:

None

**COMMISSION-SUPPLIED MATERIALS, EQUIPMENT
AND SUPPLIES TO BE INCORPORATED INTO THE WORK:**

Qty 5 – 20A GE Bolt-on GFCI Single Breakers

Qty 7 – 20A GE Bolt-on GFVI Dual Breakers

Qty 2 – 20A Square "D" GFCI Single Breakers

THE WORK ORDERED PURSUANT TO THIS WORK AUTHORIZATION ORDER

IS IS NOT **PRIORITY EMERGENCY WORK**

SUBMITTALS REQUESTED:

None

SUPPLEMENTARY NOTIFICATION OF POTENTIALLY HAZARDOUS CONDITIONS:

None

SUPPLEMENTARY CONTRACT SPECIFICATIONS AND DRAWINGS:

None

DUPAGE WATER COMMISSION

By: _____
Signature of Authorized
Representative

DATE: _____

CONTRACTOR RECEIPT ACKNOWLEDGED AND DESIGNATION OF SAFETY REPRESENTATIVE:

By: _____
Signature of Authorized
Representative

Safety Rep: _____
Name and 24-Hr Phone No.

DATE: _____

DuPage Water Commission
QRE-8.012 WAO
List of Remote Facilities for Volt Electric

MS6A – 261 ANN ST, CLAREDON HILLS

MS7A – 1220 PLAINFEILD RD, DARIEN

MS7B/8F – 2101 75TH ST, DARIEN

MS8A – 5300 S PARK DR, DOWNERS GROVE

MS8B – MAIN ST & SUMMIT ST, DOWNERS GROVE

MS8C – 75TH ST & LEMONT RD, DOWNERS GROVE

MS8E – 2250 MAPLE AVE, DOWNERS GROVE

MS15A – 1699 RANCHVIEW DR, NAPERVILLE

MS15C – CHICAGO AVE & OLESEN DR, NAPERVILLE

MS17A – 746 E OLIVIABROOK DR, OAK BROOK TERRACE

MS17B – BUTTERFIELD RD AND TRANS AM PLAZA DR, OAK BROOK TERRACE

MS24A – 1577 75TH ST, WOODRIDGE

MS24B – 7642 WOODRIDGE DR, WOODRIDGE

TS1 – NEAR MONACO DR. AND CENTRAL AVE, ROSELLE

WORK AUTHORIZATION ORDER

SHEET 1 OF 2

CONTRACT QRE-8/17: QUICK RESPONSE ELECTRICAL CONTRACT

PROJECT: QRE-8.013

LOCATIONS:

Various locations, see attached list

CONTRACTOR:

McWilliams Electric. Co., Inc.

DESCRIPTION OF WORK:

MS1A & MS14D: Replace poured in place ¾" conduit with surface mounted conduit and re-pull cables for one meter at each location.

MS5B: Replace conduit Junction Tee with J-Box, pull ground wires to receptacles

MS1A, 1D, 2A, 5B, 19A, 19B, 21C, 23A: Test all GFCI breakers and replace as needed.

ROV11A: 30A Dual Breaker for SPD is not seated properly, correct.

While covers are off breaker panels: clean in side of panel, check all connections, and inspect for any code violations. When at meter stations with two panels (LP & HP) open both panels to inspect.

REASON FOR WORK:

Correct electrical problems found by DWC staff at various remote facilities.

MINIMUM RESPONSE TIME:

None

COMMISSION-SUPPLIED MATERIALS, EQUIPMENT AND SUPPLIES TO BE INCORPORATED INTO THE WORK:

Qty 5 – 20A GE Bolt-on GFCI Single Breakers

Qty 7 – 20A GE Bolt-on GFCI Dual Breakers

THE WORK ORDERED PURSUANT TO THIS WORK AUTHORIZATION ORDER

IS IS NOT PRIORITY EMERGENCY WORK

SUBMITTALS REQUESTED:

None

SUPPLEMENTARY NOTIFICATION OF POTENTIALLY HAZARDOUS CONDITIONS:

None

SUPPLEMENTARY CONTRACT SPECIFICATIONS AND DRAWINGS:

None

DUPAGE WATER COMMISSION

By: _____
Signature of Authorized
Representative

DATE: _____

CONTRACTOR RECEIPT ACKNOWLEDGED AND DESIGNATION OF SAFETY REPRESENTATIVE:

By: _____
Signature of Authorized
Representative

Safety Rep: _____
Name and 24-Hr Phone No.

DATE: _____

DuPage Water Commission

QRE-8.013 WAO

List of Remote Facilities for McWilliams Electric

MS1A – WINTHROP AVE & VISTA AVE, ADDISON

MS1D – CHESTNUT ST & WOODLAND AVE, ADDISON

MS2A – CHURCH ST & MAIN ST, BENSENVILLE

MS5B – GRAND AVE & CROWN RD, ELMHURST

MS14D – STEWARD AVE & NORTON ST, LOMBARD

MS19A – 461 CORNELL AVE, VILLA PARK

MS19B – 31 W HOME, VILLA PARK

MS21C – 615 COUNTRYSIDE DR, WHEATON

MS23A – 326 RICHERT RD, WOOD DALE

ROV11A – 1681 BLOOMINGDALE RD, GLENDALE HEIGHTS

DATE: August 8, 2019

REQUEST FOR BOARD ACTION

AGENDA SECTION	Omnibus Vote Requiring Majority Vote	ORIGINATING DEPARTMENT	Pipeline
ITEM	A Resolution Directing Advertisement for Bids on a Contract for the Fabrication of Valve Stem Risers (Contract VSR-2/19) Resolution No. R-29-19	APPROVAL 	
Account Number: 01-60-663100			
<p>At the April 18, 2019 Commission Meeting, the Board approved Ordinance O-2-19: A Management Budget for Fiscal Year 2019-2020 which included the replacement of existing blow off valve stems.</p> <p>Corrosion of the steel valve stems installed on blow off valves during the initial construction of the distribution system have been prone to fail while being operated. Staff wishes to replace these existing valve stems with others fabricated from corrosion resistant stainless steel at 445 separate and discreet locations within the Commission's distribution system.</p> <p>Resolution No. R-29-19 would authorize the advertisement for a contract to fabricate and deliver 445 Stainless Steel Valve Stems of varying lengths to the Commission's Elmhurst Material Storage Facility. Installation of the stems will be completed, by and large, by Commission staff. However, certain installations may require assistance from the Commission QR-11/17 contractor(s) because of the valve's depth and/or scope of work. Work requiring contractor assistance will be authorized and paid for separately under the terms and conditions set forth under Contract QR-11/17. There is no cost component associated with this action other than a nominal cost for print advertisement.</p>			
MOTION: To approve Resolution No. R-29-19.			

DuPAGE WATER COMMISSION

RESOLUTION NO. R-29-19

A RESOLUTION DIRECTING ADVERTISEMENT FOR BIDS ON A
CONTRACT FOR THE FABRICATION OF VALVE STEM RISERS.
(Contract VSR-2/19)

BE IT RESOLVED by the Board of Commissioners of the DuPage Water Commission as follows:

SECTION ONE: Advertisement for Bids. The General Manager is hereby authorized and directed to advertise for bids for the contract entitled "Contract for the Fabrication of Valve Stem Risers—Contract VSR-2/19 (the "Contract") in accordance with the requirements of 65 ILCS 5/11-135-5.

SECTION TWO: Notice Inviting Bids. The Notice inviting bids on the Contract shall be in substantially the form of the "Invitation for Bidder's Proposals" attached hereto and by this reference incorporated herein and made a part hereof as Exhibit A.

SECTION THREE: Requirements for Bidding. Sealed envelopes or packages containing proposals for the performance of the Contract shall be submitted to the Commission in accordance with the "Contract/Proposal for The Fabrication of Valve Stem Risers" substantially in the form attached hereto and by this reference incorporated herein and made a part hereof as Exhibit B.

SECTION FOUR: Awarding of Contract. The Commission will award the Contract to the bidder whose proposal is found to be in the best interests of the Commission. The bidder who is to receive an award shall be determined in accordance with Article VIII of the Commission By-Laws, and the Contract/Proposal for The Fabrication of Valve Stem Risers substantially in the form attached hereto as Exhibit B.

Resolution No. R-29-19

SECTION FIVE: Approval of Bonds. The approval of the contractor's faithful performance bonds shall be subject to the requirements set forth under the subheading "Performance and Payment Bonds" in the Invitation for Bidder's Proposals attached hereto as Exhibit A.

SECTION SIX: Effective Date. This resolution shall be in full force and effect from and after its adoption.

AYES:

NAYS:

ABSENT:

ADOPTED this _____ day of _____, 2019.

Vice Chairman

ATTEST:

Clerk

Board/Resolutions/R-29-19.doc

EXHIBIT A

DUPAGE WATER COMMISSION

REQUEST FOR PROPOSALS

OWNER:

DuPage Water Commission
600 East Butterfield Road
Elmhurst, Illinois 60126-4642

Owner will receive sealed proposals for the Work generally described as follows:

FABRICATION OF VALVE STEM RISERS

TO BE SUBMITTED TO DuPage Water Commission, 600 East Butterfield Road, Elmhurst, Illinois 60126-4642, Attention John F. Spatz, Jr., General Manager, BEFORE 1:00 P.M., **TBD**

INSTRUCTIONS TO BIDDERS

Preparation of Proposals

All proposals for the Work shall be made only on the blank Contract/Proposal form attached to this Request for Proposals, FOB Point of Destination Elmhurst, Illinois, and shall be complete with a price for each and every item named in the Schedule of Prices attached to the Contract/Proposal form. All proposals shall be dated on page 4 of the Contract/Proposal form and shall be signed by an authorized official, including page 5 of the Contract/Proposal form and the Schedule of Prices attached to the Contract/Proposal. Proposals that contain omissions, erasures, alterations, or additions not called for, conditional or alternate bids unless called for, or that contain irregularities of any kind may be rejected.

Clarifications

Owner reserves the right to make clarifications, corrections, or changes in this Request for Proposals at any time prior to the time proposals are opened. Any such clarifications, corrections, or changes will be in writing. All bidders or prospective bidders will be informed of said clarifications, corrections, or changes. No claim based on oral modifications will be permitted. If any prospective bidder has questions about this Request for Proposals, contact Ed Kazmierczak, Pipeline Supervisor, at 630-834-0100 between the hours of 7:00 AM and 3:30 PM.

Delivery of Proposals

Each proposal shall be submitted in a sealed envelope plainly marked with the title of the contract and bidder's full legal name and shall be addressed and delivered to the place and before the time set forth above. Proposals may be delivered by mail or in person. Proposals received after the time specified above will be returned unopened.

Opening of Proposals

Proposals will be publicly opened and read at the time and place specified above. Bidders, their authorized agents, and interested parties are invited to be present.

Withdrawal of Proposals

No proposal shall be withdrawn for a period of 60 days after the opening of any proposal. A Bidder may withdraw its

proposal any time before bid opening by delivering a written notice of withdrawal to the person to whom proposals are submitted before bid opening.

Rejection of Proposals

Proposals that are not submitted on the Contract/Proposal form or that are not prepared in accordance with these Instructions to Bidders may be rejected. If not rejected, Owner may demand correction of any deficiency and accept the deficiently prepared proposal upon compliance with these Instructions to Bidders.

Acceptance of Proposals

Proposals submitted are offers only and the decision to accept or reject is a function of quality, reliability, capability, reputation, and expertise of the bidders.

Owner reserves the right to accept the proposal that is, in its judgment, the best and most favorable to the interests of Owner and to the public; to reject the low price proposal and to award the contract to other than the low bidder; to accept any item of any proposal; to reject any and all proposals; and to waive irregularities and informalities in any proposal submitted or in the request for proposal process; provided, however, the waiver of any prior defect or informality shall not be considered a waiver of any future or similar defect or informality. Bidders should not rely upon, or anticipate, such waivers in submitting their proposal.

Upon acceptance of the successful Bidder's proposal by Owner, the successful Bidder's proposal, together with Owner's notification of acceptance in the form attached to this Request for Proposals, shall become the contract for the Work.

DATED this **TBD** day of **TBD**

DUPAGE WATER COMMISSION

By: /s/ John F. Spatz, Jr.
General Manager

EXHIBIT B

DUPAGE WATER COMMISSION
CONTRACT/PROPOSAL FOR THE
FABRICATION OF VALVE STEM RISERS

Full Name of Bidder _____ ("Bidder")
Principal Office Address _____
Local Office Address _____
Contact Person _____ Telephone Number _____

TO: DuPage Water Commission ("Owner")
600 East Butterfield Road
Elmhurst, Illinois 60126-4642
Attention: John F. Spatz, Jr.
General Manager

Bidder warrants and represents that Bidder has carefully reviewed and understood all documents included, referred to, or mentioned in this bound set of documents, including Addenda Nos. _____ [if none, write "NONE"], which are securely stapled to the end of this Contract/Proposal.

Contract/Proposal, and with the greatest economy, efficiency, and expedition consistent therewith, with only new, undamaged, and first quality equipment, materials, and supplies.

1. Work Proposal

A. Contract and Work. If this Contract/Proposal is accepted, Bidder proposes, and agrees, that Bidder shall, at its sole cost and expense, provide, perform, and complete, in the manner specified and described, and upon the terms and conditions set forth, in this Contract/Proposal and Owner's written notification of acceptance in the form included in this bound set of documents, all of the following, all of which is herein referred to as the "Work":

1. Labor, Equipment, Materials and Supplies. Provide, perform, and complete, in the manner specified and described in this Contract/Proposal, all necessary work, labor, services, transportation, equipment, materials, supplies, information, data, and other means and items necessary for Valve Stem Riser Fabrication and delivery;
2. Permits. Procure and furnish all permits, licenses, and other governmental approvals and authorizations necessary in connection therewith;
3. Insurance. Procure all insurance specified in this Contract/Proposal;
4. Taxes. Pay all applicable federal, state, and local taxes;
5. Miscellaneous. Do all other things required of Bidder by this Contract/Proposal; and
6. Quality. Provide, perform, and complete all of the foregoing in a proper and workmanlike manner, consistent with highest standards of professional and construction practices, in full compliance with, and as required by or pursuant, to this

B. Performance Standards. If this Contract/Proposal is accepted, Bidder proposes, and agrees, that all Work shall be fully provided, performed, and completed in accordance with the specifications attached hereto and by this reference made a part of this Contract/Proposal, and by the drawing attached hereto and by this reference made a part of this Contract/Proposal. No provision of any referenced standard, specification, manual, or code shall change the duties and responsibilities of Owner or Bidder from those set forth in this Contract/Proposal.

C. Responsibility for Damage or Loss. If this Contract/Proposal is accepted, Bidder proposes, and agrees, that Bidder shall be responsible and liable for, and shall promptly and without charge to Owner repair or replace, damage done to, and any loss or injury suffered by, Owner, the Work, or other property or persons as a result of the Work.

D. Inspection/Testing/Rejection. Owner shall have the right to inspect all or any part of the Work and to reject all or any part of the Work that is, in Owner's judgment, defective or damaged or that in any way fails to conform strictly to the requirements of this Contract/Proposal and Owner, without limiting its other rights or remedies, may require correction or replacement at Bidder's cost, perform or have performed all Work necessary to complete or correct all or any part of the Work that is defective, damaged, or nonconforming and charge Bidder with any excess cost incurred thereby, or cancel all or any part of any order or this Contract/Proposal. Work so rejected may be returned or held at Bidder's expense and risk.

2. Contract Price Proposal

If this Contract/Proposal is accepted, Bidder proposes, and agrees, that Bidder shall take in full payment for all Work and other matters set forth under Section 1 above, including overhead and profit; taxes, contributions, and premiums; and compensation to all subcontractors and suppliers, the compensation set forth below.

A. SCHEDULE OF PRICES

For providing, performing, and completing all Work, the sum of the products resulting from multiplying the actual number of acceptable units of Unit Price Items listed in the Schedule of Prices attached hereto by the Unit Price set forth the Schedule of Prices attached hereto.

B. BASIS FOR DETERMINING PRICES

It is expressly understood and agreed that:

1. All prices stated in the Schedule of Prices are firm and shall not be subject to escalation or change;
2. Owner is not subject to state or local sales, use, and excise taxes, that no such taxes are included in the Schedule of Prices, and that all claim or right to claim any additional compensation by reason of the payment of any such tax is hereby waived and released;
3. All other applicable federal, state, and local taxes of every kind and nature applicable to the Work are included in the Schedule of Prices;
4. The approximate quantities set forth in the Schedule of Prices for each Unit Price Item are Owner's estimate only, that Owner reserves the right to increase or decrease such quantities, that payment for each Unit Price Item shall be made only on the actual number of acceptable units of such Unit Price Item delivered to Owner in full compliance with this Contract/Proposal, and that all claim or right to dispute or complain of any such estimated quantity, or to assert that there was any misunderstanding in regard to the nature or amount of any Unit Price Item to be provided or performed, is hereby waived and released; and
5. Any items of Work not specifically listed or referred to in the Schedule of Prices, or not specifically included for payment under any Unit Price Item, shall be deemed incidental to the Contract Price, shall not be measured for payment, and shall not be paid for separately except as incidental to the Contract Price, including without limitation the cost of transportation, FOB Point of Destination Elmhurst, Illinois, packing, cartage, and containers.

C. VALUE OF WORK

It is expressly understood and agreed that the value of the Work shall be determined as follows:

1. The value of Work shall be determined by Owner based on the actual number of acceptable units of Unit Price Items delivered to Owner multiplied by the applicable Unit Price set forth in the Schedule of Prices.

2. The number of units of Unit Price Items stated in the Schedule of Prices are Owner's estimate only and shall not be used in establishing payments due Bidder.
3. The Contract Price shall be adjusted to reflect the actual number of acceptable units of Unit Price Items delivered to Owner upon final acceptance of the Work by Owner.

D. TIME OF PAYMENT

It is expressly understood and agreed that the Contract Price shall be paid in monthly installments in the manner set forth below ("Progress Payments"). Payments will be made according to the Illinois Local Government Prompt Payment Act (50 ILCS 505/1 it seq.)

Owner shall pay to Bidder the value of Work, determined in the manner set forth above, delivered to Owner up to the day before the Pay Request, less the aggregate of all previous Progress Payments.

All payments may be subject to deduction or setoff by reason of any failure of Bidder to perform under this Contract/Proposal. Each Pay Request shall include Bidder's certification of the value of, and partial or final waivers of lien covering, all Work for which payment is then requested and Bidder's certification that all prior payments have been properly applied to the payment or reimbursement of the costs with respect to which they were paid.

3. Contract Time Proposal

If this Contract/Proposal is accepted, Bidder proposes, and agrees, that Bidder shall commence the Work within 10 days following Owner's acceptance of this Contract/Proposal (the "Commencement Date"). If this Contract/Proposal is accepted, Bidder proposes, and agrees, that Bidder shall perform the Work diligently and continuously and shall complete the Work, including delivery FOB Point of Destination to the DuPage Water Commission, 600 East Butterfield Road, Elmhurst, IL, between the hours of 7:00 a.m. and 3:30 p.m. Monday through Friday not later than 120 days following the Commencement Date.

4. Financial Assurance

A. Insurance. If this Contract/Proposal is accepted, Bidder proposes, and agrees, that Bidder will procure and maintain such insurance as will cover and include the entire obligation assumed by Bidder in this Contract/Proposal, as well as public liability insurance, including contractual liability, contractors liability and protective liability, automobile liability insurance, including non-owned automobile liability, and Workmen's Compensation and employer's liability insurance as will adequately protect Owner, the Work, and other property and persons against all damages, liability claims, losses and expenses (including attorney's fees) which may arise, or be alleged to have arisen, out of or in connection with Bidder's performance of, or failure to perform, the Work or any part thereof.

B. Indemnification. If this Contract/Proposal is accepted, Bidder proposes, and agrees, that, to the fullest extent

permitted by law, Bidder shall indemnify, save harmless, and defend Owner against all damages, liability, claims, losses, and expenses (including attorneys' fees) that may arise, or be alleged to have arisen, out of or in connection with Bidder's performance of, or failure to perform, the Work or any part thereof, or any failure to meet the representations and warranties set forth in Section 6 of this Contract/Proposal.

C. Penalties. If this Contract/Proposal is accepted, Bidder proposes, and agrees, that Bidder shall be solely liable for any fines or civil penalties that are imposed by any governmental or quasi-governmental agency or body that may arise, or be alleged to have arisen, out of or in connection with Bidder's performance of, or failure to perform, the Work or any part thereof.

5. Firm Proposal

All prices and other terms stated in this Contract/Proposal are firm and shall not be subject to withdrawal, escalation, or change provided Owner accepts this Contract/Proposal within 60 days after the date this sealed Contract/Proposal is opened.

6. Bidder's Representations and Warranties

In order to induce Owner to accept this Contract/Proposal, Bidder hereby represents and warrants as follows:

A. The Work. The Work, and all of its components, shall be of merchantable quality; shall be free from any latent or patent defects and flaws in workmanship, materials, and design; shall strictly conform to the requirements of this Contract/Proposal, including, without limitation, the performance standards set forth in this Contract/Proposal; and shall be fit, sufficient, and suitable for the purposes expressed in, or reasonably inferred from, this Contract/Proposal and the warranties expressed herein shall be in addition to any other warranties expressed or implied by law, which are hereby reserved unto Owner. Bidder shall, promptly and without charge, correct any failure to fulfill the above warranty at any time within two years after final payment or such longer period as may be prescribed in the performance standards set forth in this Contract/Proposal or by law. The above warranty shall be extended automatically to cover all repaired and replacement parts and labor provided or performed under such warranty and Bidder's obligation to correct Work shall be extended for a period of two years from the date of such repair or replacement. The time period established in this Section 6A relates only to the specific obligation of Bidder to correct Work and shall not be construed to establish a period of limitation with respect to other obligations that Bidder has under this Contract/Proposal.

B. Compliance with Laws. The Work, and all of its components, shall be provided, performed, and completed in compliance with, and Bidder agrees to be bound by, all applicable federal, state, and local laws, orders, rules, and regulations, as they may be modified or amended from time to time, including without limitation any prevailing wage laws; any statutes requiring preference to laborers of specified classes; the Illinois Steel Products Procurement Act, 30 ILCS 565/1 et seq.; any statutes prohibiting discrimination because of, or requiring affirmative action based on, race, creed, color, national origin, age, sex, or other prohibited classification; and any statutes regarding safety or the performance of the Work.

C. Not Barred. Bidder is not barred by law from contracting with Owner or with any other unit of state or local government for any reason, including without limitation as a result of (i) a violation of either Section 33E-3 or Section 33E-4 of Article 33 of the Criminal Code of 1961, 720 ILCS 5/33E-1 et seq.; or (ii) a violation of the USA Patriot Act of 2001, 107 Public Law 56 (October 26, 2001) (the "Patriot Act") or other statutes, orders, rules, and regulations of the United States government and its various executive departments, agencies and offices related to the subject matter of the Patriot Act, including, but not limited to, Executive Order 13224 effective September 24, 2001. Bidder is not acting, directly or indirectly, for or on behalf of any person, group, entity or nation named by the United States Treasury Department as a Specially Designated National and Blocked Person, or for or on behalf of any person, group, entity or nation designated in Presidential Executive Order 13224 as a person who commits, threatens to commit, or supports terrorism; and Bidder is not engaged in this transaction directly or indirectly on behalf of, or facilitating this transaction directly or indirectly on behalf of, any such person, group, entity or nation.

D. Qualified. Bidder has the requisite experience, ability, capital, facilities, plant, organization, and staff to enable Bidder to perform the Work successfully and promptly and to commence and complete the Work within the Contract Price and Contract Time Proposals set forth above.

7. Acknowledgements

In submitting this Contract/Proposal, Bidder acknowledges and agrees that:

A. Reliance. Owner is relying on all warranties, representations, and statements made by Bidder in this Contract/Proposal.

B. Reservation of Rights. Owner reserves the right to reject all proposals, reserves the right to reject the low price proposal, and reserves such other rights as are set forth in the Instructions to Bidders.

C. Acceptance. If this Contract/Proposal is accepted, Bidder shall be bound by each and every term, condition, or provision contained in this Contract/Proposal and in Owner's written notification of acceptance in the form included in this bound set of documents.

D. Remedies. Each of the rights and remedies reserved to Owner in this Contract/Proposal shall be cumulative and additional to any other or further remedies provided in law or equity or in this Contract/Proposal. The election of one remedy shall not waive any other remedies available to Owner.

E. Time. Time is of the essence of this Contract/Proposal and, except where stated otherwise, references in this Contract/Proposal to days shall be construed to refer to calendar days.

F. No Waiver. No examination, inspection, investigation, test, measurement, review, determination, decision, certificate, or approval by Owner, whether before or after Owner's acceptance of this Contract/Proposal; nor any information or data supplied by Owner, whether before or after Owner's acceptance of this Contract/Proposal; nor any order by Owner for the payment of money; nor any payment for, or use, possession, or acceptance of, the whole or any part of the

Work by Owner; nor any extension of time granted by Owner; nor any delay by Owner in exercising any right under this Contract/Proposal; nor any other act or omission of Owner shall constitute or be deemed to be an acceptance of any defective, damaged, or nonconforming Work, nor operate to waive or otherwise diminish the effect of any representation or warranty made by Bidder; or of any requirement or provision of this Contract/Proposal; or of any remedy, power, or right of Owner.

G. Severability. The provisions of this Contract/Proposal shall be interpreted when possible to sustain their legality and enforceability as a whole. In the event any provision of this Contract/Proposal shall be held invalid, illegal, or unenforceable by a court of competent jurisdiction, in whole or in part, neither the validity of the remaining part of such provision, nor the validity of any other provisions of this Contract/Proposal shall be in any way affected thereby.

H. Amendments. No modification, addition, deletion, revision, alteration, or other change to this Contract/Proposal shall be effective unless and until such change is reduced to writing and executed and delivered by Owner and Bidder.

I. Assignment. Neither this Contract/Proposal, nor any interest herein, shall be assigned or subcontracted, in whole or in part, by Bidder except upon the prior written consent of Owner.

J. Governing Law. This Contract/Proposal, and the rights of the parties under this Contract/Proposal shall be interpreted according to the internal laws, but not the conflict of

law rules, of the State of Illinois. Every provision of law required by law to be inserted into this Contract/Proposal shall be deemed to be inserted herein. . In the event any party files suit under or regarding this Contract, the only proper jurisdiction and venue shall be the Circuit Court of the Eighteenth Judicial Circuit, DuPage County, Illinois; the parties hereby consent to said venue and the jurisdiction of that court and waive any objection to said venue.

K. Attorney's Fees. If the Owner engages an attorney to enforce this Contract or to initiate litigation to enforce, interpret or declare rights under this Contract, Owner shall be entitled to its reasonable attorney's fees from Contractor.

L. Limitation on Claims. The Contractor shall commence all claims and causes of action, whether in contract, tort, breach of warranty or otherwise, against the Owner arising out of or related to the Contract within the time period specified by applicable law, but in any case not more than two (2) years after the date of completion of the Work. The Contractor waives all claims and causes of action not commenced in accordance with this Section.

8. Contract Documents

The Contract shall include the Instructions to Bidders, Contract/Proposal, Specifications, and all attachments and exhibits thereto.

DATED this _____ day of _____, 20__.

Bidder's Status: () _____ Corporation () _____ Partnership () Individual Proprietor
(State) (State)

Bidder's Name: _____

Doing Business As (if different): _____

Signature of Bidder or Authorized Agent: _____

(corporate seal)
(if corporation)

Printed Name: _____

Title/Position: _____

Bidder's Business Address: _____

Bidder's Business Telephone: _____ Facsimile: _____

If a Corporation or Partnership, list all Officers or Partners:

NAME	TITLE	ADDRESS

SPECIFICATIONS

If the Contract/Proposal is accepted, Bidder proposes, and agrees, that all Work shall be fully provided, performed, and completed in accordance with the following specifications:

1. Material

- A. Unless otherwise noted, all material incorporated into the valve stem riser fabrications shall be Type 304 Stainless Steel having a minimum thickness of .250.

2. Welding and Assembly

- A. All components of the work shall be welded in accordance with American Welding Society D1.1 Structural Welding Codes to the dimensions as shown in the drawing included with this Contract/Proposal.
- B. Weld deflection shall be no more than 3 degrees from design.
- C. De-Burr all edges.
- D. Remove all weld splatter.

3. Delivery

Bidder shall provide a 48-hour notice to Owner to schedule the delivery of Valve Stem Riser assemblies FOB Point of Destination to the DuPage Water Commission, 600 East Butterfield Road, Elmhurst, IL between the hours of 7:00 a.m. and 3:30 p.m. Monday through Friday excluding holidays.

4. Publicity

Owner's name or insignia, photographs of the Work, or any other publicity pertaining to the Work shall not be used in any magazine, trade paper, newspaper, or other medium without the express written consent of Owner

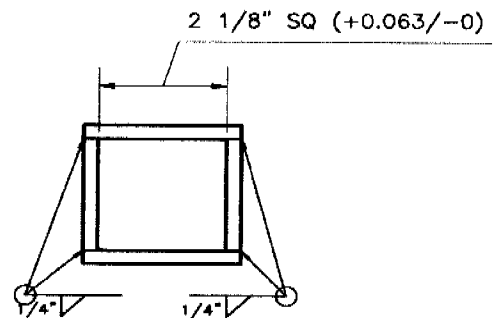
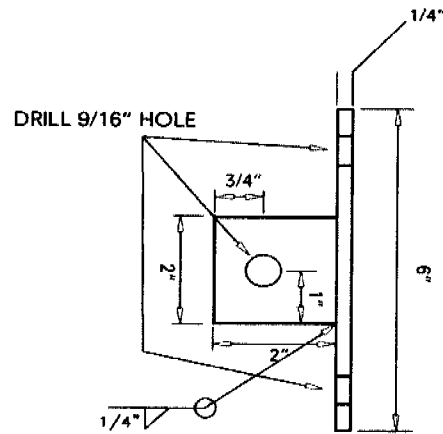
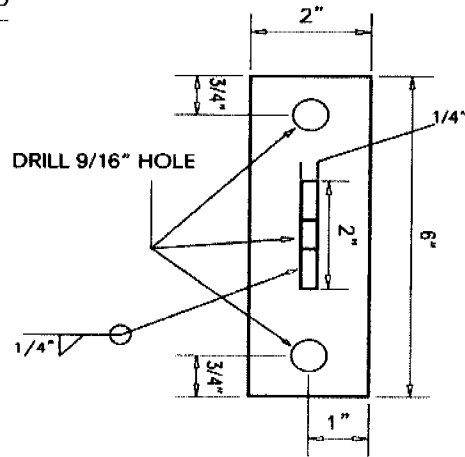
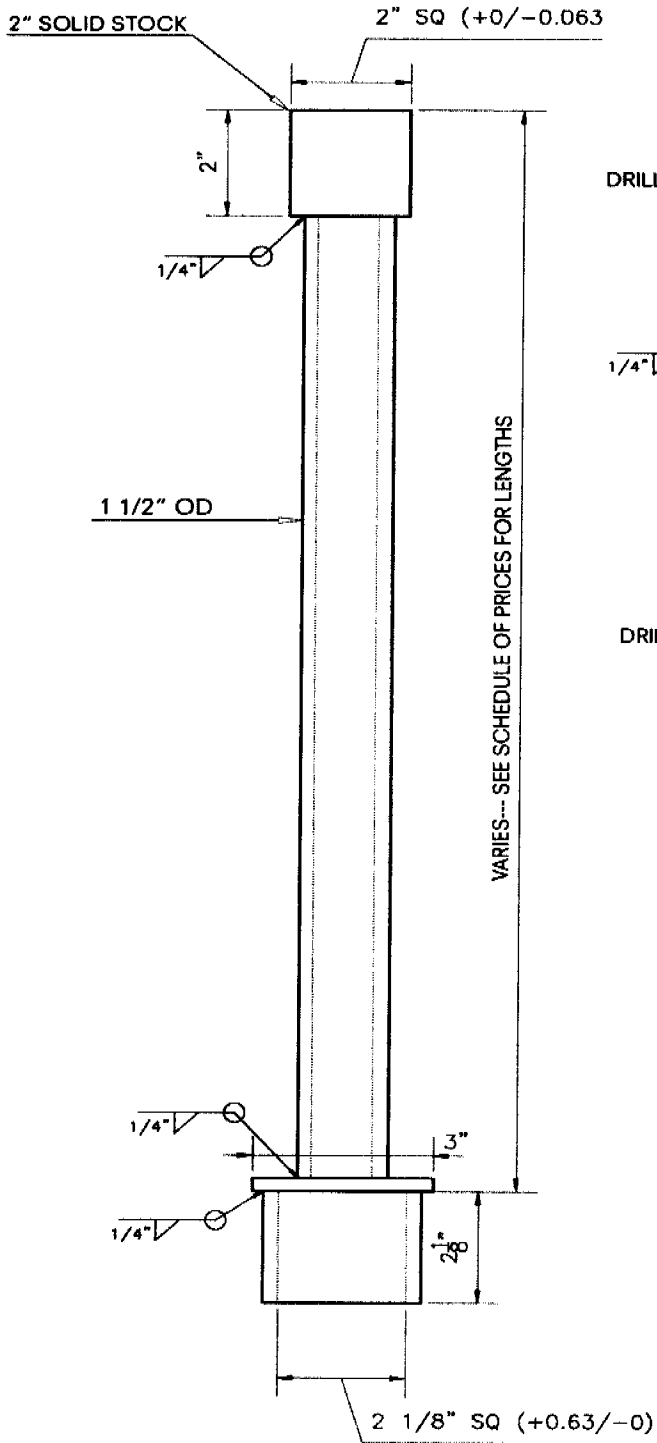

A SECTION VIEW
NO SCALE

SHAFT EXTENSION PROFILE
NO SCALE

DRAWING NOT TO SCALE

2. Owner is not subject to state or local sales, use, and excise taxes, that no such taxes are included in this Schedule of Prices, and that all claim or right to claim any additional compensation by reason of the payment of any such tax is hereby waived and released;
3. All other applicable federal, state, and local taxes of every kind and nature applicable to the Work are included in this Schedule of Prices;
4. The approximate quantities set forth in this Schedule of Prices for each Unit Price Item are Owner's estimate only, that Owner reserves the right to increase or decrease such quantities, that payment for each Unit Price Item shall be made only on the actual number of acceptable units of such Unit Price Item delivered to Owner in full compliance with the Contract/Proposal, and that all claim or right to dispute or complain of any such estimated quantity, or to assert that there was any misunderstanding in regard to the nature or amount of any Unit Price Item to be provided or performed, is hereby waived and released; and
5. Any items of Work not specifically listed or referred to in this Schedule of Prices, or not specifically included for payment under any Unit Price Item, shall be deemed incidental to the Contract Price, shall not be measured for payment, and shall not be paid for separately except as incidental to the Contract Price, including without limitation the cost of transportation, FOB Point of Destination Elmhurst, Illinois, packing, cartage, and containers.

Signature of Bidder or Authorized Agent: _____

Printed Name: _____

Title/Position: _____

ACCEPTANCE

The Contract/Proposal attached hereto and by this reference incorporated herein and made a part hereof is hereby accepted by the order of the DuPage Water Commission ("Owner") this _____ day of _____, 20__.

This Acceptance, together with the Contract/Proposal attached hereto, constitutes the entire and only agreement between the parties relating to the accomplishment of the Work and the compensation therefor and supersedes and merges any other prior or contemporaneous discussions, agreements, or understandings, whether written or oral, and shall prevail over any contradictory or inconsistent terms or conditions contained in any purchase order, acceptance, acknowledgement, invoice, or other standard form used by the parties in the performance of the Contract/Proposal. Any such contradictory or inconsistent terms or conditions shall be deemed objected to by Owner without further notice of objection and shall be of no effect nor in any circumstances binding upon Owner unless accepted by Owner in a written document plainly labeled "Amendment to Contract/Proposal." Acceptance or rejection by Owner of any such contradictory or inconsistent terms or conditions shall not constitute acceptance of any other contradictory or inconsistent terms or conditions.

DUPAGE WATER COMMISSION

By: _____
John F. Spatz, Jr.
General Manager



DuPage Water Commission

MEMORANDUM

TO: John Spatz, General Manager

FROM: Cheryl Peterson, Financial Administrator *CP*

DATE: July 9, 2019

SUBJECT: Accounts Payable Listings

Following is a summary of the Accounts Payable to be considered at the July 18, 2019 Commission meeting:

June 12, 2019 to July 9, 2019 A/P Report	\$9,001,104.08
Accrued and estimated payments required before August 2019 Commission meeting	<u>1,147,825.00</u>
Total	<u>\$10,148,929.08</u>

cc: Chairman and Commissioners



Payable Number	Description	Post Date	Payable Amount	Net Amount
Payable Account: <u>01-211000 - ACCOUNTS PAYABLE</u>				
Vendor: <u>1663</u>	AECOM			Payable Count: (2) 19,232.07
<u>2000225950</u>	Transition Main to Bartlett	06/30/2019	11,455.92	11,455.92
<u>2000228641</u>	Vulnerability Assessment	06/30/2019	7,776.15	7,776.15
Vendor: <u>2228</u>	Altorfer Industries, Inc.			Payable Count: (1) 274.50
<u>PM600282225</u>	ASCO transfer switch troubleshooting	06/25/2019	274.50	274.50
Vendor: <u>1292</u>	APWA - ILLINOIS PUBLIC SERVICE INSTITUTE			Payable Count: (1) 695.00
<u>INV0003674</u>	Training Class: Wegner	06/18/2019	695.00	695.00
Vendor: <u>1516</u>	ARAMARK REFRESHMENTS			Payable Count: (1) 53.45
<u>6703586</u>	Supplies	06/30/2019	53.45	53.45
Vendor: <u>1553</u>	AUTOMATIC CONTROL SERVICES			Payable Count: (1) 133.00
<u>4388</u>	Repair to Back up Telemetry PLC System	06/18/2019	133.00	133.00
Vendor: <u>1519</u>	BLACKBURN MFG. CO.			Payable Count: (1) 458.30
<u>0596397-IN</u>	Flags	06/30/2019	458.30	458.30
Vendor: <u>1023</u>	CDW Government			Payable Count: (1) 382.76
<u>STJ1971</u>	Electronic Licenses	06/30/2019	382.76	382.76
Vendor: <u>1135</u>	CITY OF CHICAGO SUPERINTENDENT OF WATER COLLECTION			Payable Count: (1) 8,931,100.11
<u>INV0003719</u>	WATER BILLING: June 2019	06/30/2019	8,931,100.11	8,931,100.11
Vendor: <u>2202</u>	Construction & Geotechnical Material Testing, Inc.			Payable Count: (2) 5,620.00
<u>5966</u>	Material Testing Services	06/30/2019	968.00	968.00
<u>5967</u>	Material Testing Services	06/30/2019	4,652.00	4,652.00
Vendor: <u>1798</u>	DAVID C. RUSSO			Payable Count: (1) 300.00
<u>INV0003741</u>	SERVICE AS COMMISSIONER January-June 2019	07/09/2019	300.00	300.00
Vendor: <u>2076</u>	DAVID NOVOTNY			Payable Count: (1) 300.00
<u>INV0003742</u>	SERVICE AS COMMISSIONER January-June 2019	07/09/2019	300.00	300.00
Vendor: <u>2244</u>	Diane Bouckaert			Payable Count: (1) 300.00
<u>INV0003747</u>	SERVICE AS COMMISSIONER January-June 2019	07/09/2019	300.00	300.00
Vendor: <u>1240</u>	DOOR SYSTEMS, INC.			Payable Count: (1) 504.00
<u>871013</u>	Gate Repairs	07/09/2019	504.00	504.00
Vendor: <u>1513</u>	DUKES OIL SERVICE, INC.			Payable Count: (1) 75.00
<u>88731</u>	Waste Oil Pickup	06/25/2019	75.00	75.00
Vendor: <u>1444</u>	EASTLAND INDUSTRIES, INC.			Payable Count: (1) 931.00
<u>57351</u>	ROV43A Actuator Motor Repair	06/30/2019	931.00	931.00
Vendor: <u>2003</u>	ECO CLEAN MAINTENANCE, INC.			Payable Count: (1) 1,552.98
<u>7964</u>	JANITORIAL SERVICE: June 2019	06/30/2019	1,552.98	1,552.98
Vendor: <u>2250</u>	Elmhurst Memorial Occupational Health			Payable Count: (2) 874.83
<u>INV0003749</u>	Healthcare Services: Cuvalo	06/30/2019	360.19	360.19
<u>INV0003750</u>	Healthcare Services: Dlugopolski	06/30/2019	514.64	514.64
Vendor: <u>2041</u>	F.E. MORAN, INC.			Payable Count: (1) 1,496.00
<u>001-301902161</u>	Annual Backflow Inspection	06/30/2019	1,496.00	1,496.00
Vendor: <u>1639</u>	HEAT EXCHANGER			Payable Count: (1) 200.03
<u>2225</u>	Anodes for heat exchangers	06/30/2019	200.03	200.03

Board Open Payable Report

As Of 07/09/2019

Payable Number	Description	Post Date	Payable Amount		Net Amount
Vendor: 1904 <u>01116662</u>	IT SAVVY LLC FireEye Subscription License Renewal	06/30/2019	10,492.80	Payable Count: (1)	10,492.80 10,492.80
Vendor: 1923 <u>INV0003718</u>	JOHN NERI CONSTRUCTION COMPANY, INC. Contract QR-10/17 Insurance and Bonds	07/02/2019	5,000.00	Payable Count: (1)	5,000.00 5,000.00
Vendor: 2172 <u>INV0003744</u>	Joseph Broda SERVICE AS COMMISSIONER January-June 2019	07/09/2019	300.00	Payable Count: (1)	300.00 300.00
Vendor: 2077 <u>INV0003745</u>	JOSEPH FENNELL SERVICE AS COMMISSIONER January-June 2019	07/09/2019	300.00	Payable Count: (1)	300.00 300.00
Vendor: 2130 <u>37359</u>	Lauterbach & Amen, LLP Professional Services	06/30/2019	2,600.00	Payable Count: (1)	2,600.00 2,600.00
Vendor: 2198 <u>49925</u>	Mecon Industries, Inc. Large vertical pump and motor service #2	06/30/2019	2,100.00	Payable Count: (1)	2,100.00 2,100.00
Vendor: 1110 <u>31704830</u>	NEWARK ELEMENT14 Axial Fan and components	06/30/2019	42.47	Payable Count: (1)	42.47 42.47
Vendor: 1395 <u>328274412001</u> <u>327928629001</u> <u>333671159001</u> <u>333677226001</u>	OFFICE DEPOT OFFICE SUPPLIES Office supplies OFFICE SUPPLIES OFFICE SUPPLIES	06/18/2019 06/25/2019 06/30/2019 06/30/2019	43.68 15.99 384.80 154.97	Payable Count: (4)	599.44 43.68 15.99 384.80 154.97
Vendor: 1321 <u>92760</u>	PERSPECTIVES, LTD. EMPLOYEE ASSISTANCE SVC: QUARTER 3	07/09/2019	273.00	Payable Count: (1)	273.00 273.00
Vendor: 2249 <u>INV0003746</u>	REBECCA BOYD-OBARSKI SERVICE AS COMMISSIONER January-June 2019	07/09/2019	300.00	Payable Count: (1)	300.00 300.00
Vendor: 2075 <u>INV0003743</u>	ROBERT GANS SERVICE AS COMMISSIONER January-June 2019	07/09/2019	300.00	Payable Count: (1)	300.00 300.00
Vendor: 1950 <u>2942-11</u>	RORY GROUP, LLC. Consulting Fee: July 2019	07/02/2019	1,500.00	Payable Count: (1)	1,500.00 1,500.00
Vendor: 1777 <u>764995</u>	SCHNEIDER ELECTRIC BUILDINGS AMERICA, INC HVAC BAS Server Upgrade	06/30/2019	680.00	Payable Count: (1)	680.00 680.00
Vendor: 1040 <u>971051</u> <u>972890</u> <u>974517</u>	SPECIALTY MAT SERVICE MAT SERVICE: 05/05/19 MAT SERVICE: 05/16/19 MAT SERVICE: 05/31/19	06/18/2019 06/18/2019 06/18/2019	151.17 156.87 156.87	Payable Count: (3)	464.91 151.17 156.87 156.87
Vendor: 1773 <u>3417512144</u> <u>3417915586</u>	STAPLES ADVANTAGE Office Supplies Office Supplies	06/30/2019 06/30/2019	152.65 74.85	Payable Count: (2)	227.50 152.65 74.85
Vendor: 2163 <u>7804740</u>	Sterling Talent Solutions Background Checks	06/30/2019	94.60	Payable Count: (1)	94.60 94.60
Vendor: 2035 <u>0150084</u>	STRAND ASSOCIATES, INC. SCADA RFP Evaluation Prof Services 4/1/19-5/31/19	06/30/2019	3,177.03	Payable Count: (1)	3,177.03 3,177.03
Vendor: 1367 <u>0073065</u>	THERMOSYSTEMS PARTS DIVISION Replacement Wall Air Conditioner #1 Motor & Wheel	07/09/2019	404.34	Payable Count: (1)	404.34 404.34
Vendor: 2029 <u>0000276256</u> <u>0000276417</u> <u>0000276599</u> <u>0000276770</u>	TREE TOWNS IMAGING & COLOR GRAPHICS Digital Scanning Design Printing Document Scanning Document Scanning	06/18/2019 06/30/2019 06/30/2019 06/30/2019	13.32 90.48 192.00 111.36	Payable Count: (5)	574.04 13.32 90.48 192.00 111.36

Board Open Payable Report

As Of 07/09/2019

Payable Number	Description	Post Date	Payable Amount	Net Amount
<u>0000276813</u>	Document Scanning	07/09/2019	166.88	166.88
Vendor: 1427	VILLA PARK ELECTRICAL SUPPLY CO., INC.			Payable Count: (9) 4,415.56
<u>157733-00</u>	Uniforms	06/25/2019	155.81	155.81
<u>151933-04</u>	Uniforms	06/30/2019	52.95	52.95
<u>154396-10</u>	Uniforms	06/30/2019	847.30	847.30
<u>154562-05</u>	Uniforms	06/30/2019	1,180.90	1,180.90
<u>155204-02</u>	Uniforms	06/30/2019	478.00	478.00
<u>156533-07</u>	Uniforms	06/30/2019	1,540.00	1,540.00
<u>156913-00</u>	Uniforms	06/30/2019	118.00	118.00
<u>157586-00</u>	Breaker filler plates	06/30/2019	24.60	24.60
<u>157586-02</u>	Filler Plates	06/30/2019	18.00	18.00
Vendor: 1442	WELDSTAR COMPANY			Payable Count: (1) 236.69
<u>01768641</u>	Calibration Gas for CO Monitors at DPS	07/09/2019	236.69	236.69
Vendor: 2096	William A. Fates			Payable Count: (1) 1,666.67
<u>INV0003717</u>	Service as Treasurer: July 2019	07/02/2019	1,666.67	1,666.67
Vendor: 1048	ZIEBELL WATER SERVICE PRODUCTS, INC.			Payable Count: (1) 872.00
<u>246119-000</u>	Hydrant Adapter	06/30/2019	872.00	872.00
			Payable Account 01-211000	Payable Count: (63) Total: 9,001,104.08

Payable Account Summary

Account	Count	Amount
01-211000 - ACCOUNTS PAYABLE	63	9,001,104.08
Report Total:	63	9,001,104.08

Payable Fund Summary

Fund	Count	Amount
01 - WATER FUND	63	9,001,104.08
Report Total:	63	9,001,104.08

DUPAGE WATER COMMISSION
ITEMS TO BE PAID BY 7-18-19
Board Meeting Date: July 18, 2019

Estimate Amount	Description	Check Number	Payment Date	Payment Amount
55,000.00	Blue Cross Blue Shield - Health Insurance			
6,000.00	Euclid Managers - Dental Insurance			
10,000.00	Illinois Public Risk Fund - Workers Comp.			
200.00	Envision Health Care - Administration Fees			
300.00	Healthiest You			
150.00	NCPERS - IMRF			
20,000.00	ComEd - Utility Charges			
300,000.00	Constellation (Exelon Energy) - Utility Charges			
180,000.00	City of Chicago - Lexington. Electric			
35,000.00	City of Chicago - Lexington Labor Costs			
35,000.00	City of Chicago - Repairs & Maintenance			
2,000.00	City of Naperville -Meter Station Electric Bills			
15,000.00	Nicor - Gas			
350.00	Comcast - Internet Service			
3,000.00	AT & T - Telephone Charges			
3,000.00	AT & T - Scada Backhaul Network/IP Flex			
1,000.00	Fed - Ex - Postage/Delivery			
5,000.00	Procurement Card Charges			
200.00	Anderson - Pest Control			
400.00	Republic Services - Disposal Services			
200.00	Elecsys - Cell Data Services			
1,500.00	Konica Minolta - Copy and Lease Charges			
625.00	Pitney Bowes - Postage			
8,000.00	Grainger - Supplies for Operations			
2,500.00	Verizon - Wireless Service			
300.00	Verizon Connect - Diagnostics			
50.00	City of Aurora - Microbial Analysis			
50.00	Bridgepoint - Hosting Services			
1,700.00	William Fates - Treasurer			
5,000.00	Baker Tilly			
15,000.00	Schirott, Luetkehans & Garner, LLC			
1,500.00	Rory Group			
7,000.00	IT Savvy - Network Support			
200.00	Edward Coughlin/Ken Labin - Security			
600.00	Red Wing - Uniforms			
500.00	Elmhurst Standard Plaza - Vehicle Maintenance			
200.00	Soooper Lube - Vehicle Maintenance			
500.00	Storino Ramello & Durkin			
500.00	Local 399 Training courses			
400.00	AWWA Membership Renewal			
2,300.00	Badger Meter - Meter Cellular Data			
4,000.00	Beary - June Landscaping			
2,000.00	Bedrock - June Landscaping			

DUPAGE WATER COMMISSION
ITEMS TO BE PAID BY 7-18-19
Board Meeting Date: July 18, 2019

800.00 DuPont - Training Videos
2,200.00 Enespro - Arc Flash Shield Assembly
13,000.00 EZ GO - Cushman Hauler
700.00 Farwest - Pipeline Supplies
2,000.00 Gas Depot - Gasoline
17,000.00 Ground Pro - Landscape Restoration
2,900.00 Hach - Monthly Chemicals
1,300.00 Hach Company - Laboratory Test Kits
7,000.00 HSQ Technology - MS Surface Upgrades
1,000.00 Irthnet - Conference
500.00 Industrial Tool Products - Pavement breaking tools
300.00 JJ Keller - Subscription Renewal
42,000.00 Mecon - Large pump transport
180,000.00 Mecon - Butterfly Valve Transport
2,500.00 MK Battery - Batteries
100.00 McMaster Carr - Batteries
3,000.00 NIU - Supervisor Safety Training
500.00 NFPA - Membership renewal
800.00 Pace - Audio Services
900.00 Program One - Window Cleaning
3,000.00 Russo Power Equipment - Trailer Repair
400.00 Specialty Mat - Carpet Cleaning
2,000.00 Tanknology - Fuel Tank Inspections
100.00 Thompson Elevator - Semi Annual Inspection
800.00 TPC Training - Training Videos
100.00 Tree Town - Copies
2,500.00 Triton Electronics - Annual Calibration
300.00 Transcat - Amprobe Testing
5,000.00 Thomas Pump Company - Sump Pumps
500.00 Villa Park Electric - Filler Plates
400.00 AECOM - Arc Flash Studies
7,500.00 AECOM - Electrical Safety Studies
10,000.00 CDMSmith - DPPS Improvements
7,500.00 Greeley and Hansen - Bartlett MS Eng.
35,000.00 Greeley and Hansen - DPPS Disinfection Facilities
15,000.00 Knight E/A - DPPS HVAC Improvements
35,000.00 Strand Assoc. - Tanksite Improvements
18,000.00 Oak Security - DPS Electronic Lock Install

1,147,825.00



DuPage Water Commission

MEMORANDUM

TO: John Spatz, General Manager

FROM: Cheryl Peterson, Financial Administrator *CP*

DATE: August 6, 2019

SUBJECT: Accounts Payable Listings

Following is a summary of the Accounts Payable to be considered at the August 15, 2019 Commission meeting:

July 10, 2019 to August 6, 2019 A/P Report	\$11,158,828.80
Accrued and estimated payments required before September 2019 Commission meeting	<u>940,525.00</u>
Total	<u>\$12,099,353.80</u>

cc: Chairman and Commissioners



DuPage Water Commission

Board Open Payable Report

As Of 08/06/2019

Summarized by Payable Account

Payable Number	Description	Post Date	Payable Amount	Net Amount
Payable Account: 01-211000 - ACCOUNTS PAYABLE				
Vendor: <u>1663</u> <u>2000238555</u>	AECOM Hydraulic Modeling	07/30/2019	5,216.64	Payable Count: (1) 5,216.64
Vendor: <u>1778</u> <u>31660</u>	ASSOCIATED TECHNICAL SERVICES, LTD Leak Detection Service	07/30/2019	721.00	Payable Count: (1) 721.00
Vendor: <u>2173</u> <u>MA44159</u>	Atomatic Mechanical Services, Inc. HVAC Quarterly Services June-Aug 2019	07/16/2019	1,996.00	Payable Count: (1) 1,996.00
Vendor: <u>1017</u> <u>P17175583</u>	BATTERIES PLUS Batteries	07/31/2019	101.91	Payable Count: (1) 101.91
Vendor: <u>1980</u> <u>139748</u>	BEARY LANDSCAPE MANAGEMENT Irrigation Repairs	07/31/2019	836.60	Payable Count: (1) 836.60
Vendor: <u>1731</u> <u>INV0003791</u>	Benchmark Construction Co, Inc. Estimate No: Eight RS	07/30/2019	324,374.88	Payable Count: (1) 324,374.88
Vendor: <u>1135</u> <u>INV0003812</u>	CITY OF CHICAGO SUPERINTENDENT OF WATER COLLECTION WATER BILLING: July 2019	07/31/2019	10,790,295.39	Payable Count: (1) 10,790,295.39
Vendor: <u>1140</u> <u>INV0003814</u>	CITY OF ELMHURST WIRELESS RADIO: MAINT&MONITOR	08/06/2019	255.00	Payable Count: (1) 255.00
Vendor: <u>1821</u> <u>186810</u>	COLLEY ELEVATOR COMPANY Elevator Testing	07/25/2019	225.00	Payable Count: (1) 225.00
Vendor: <u>1262</u> <u>115552705</u>	COMSEARCH Frequency Protection Service	07/23/2019	456.00	Payable Count: (1) 456.00
Vendor: <u>1432</u> <u>10812A</u>	DUPAGE MAYORS AND MANAGERS CONFERENCE Recognition Ceremony	07/31/2019	630.00	Payable Count: (1) 630.00
Vendor: <u>2003</u> <u>8025</u>	ECO CLEAN MAINTENANCE, INC. Frequency Protection Service	07/23/2019	1,552.98	Payable Count: (1) 1,552.98
Vendor: <u>1654</u> <u>SIP-E102721</u>	ELECSYS CORPORATION Repaire Smart Node	07/31/2019	380.22	Payable Count: (1) 380.22
Vendor: <u>1570</u> <u>2487725</u>	FIVE STAR SAFETY EQUIPMENT, INC. Traffic Cones	07/31/2019	406.80	Payable Count: (1) 406.80
Vendor: <u>1057</u> <u>167568</u>	HSQ TECHNOLOGY Service Engineer Support for TS1 VFD Upgrade	07/25/2019	6,400.00	Payable Count: (1) 6,400.00
Vendor: <u>1949</u> <u>129</u>	JOHN J. MILLNER AND ASSOCIATES, INC. Consulting Services Quarter 3 2019	07/30/2019	6,000.00	Payable Count: (1) 6,000.00
Vendor: <u>1110</u> <u>31797221</u>	NEWARK ELEMENT14 Replacement Fans	07/23/2019	81.43	Payable Count: (1) 81.43
Vendor: <u>2026</u> <u>201947702</u>	ONYX Supplies	07/31/2019	271.59	Payable Count: (1) 271.59
Vendor: <u>1664</u> <u>126041</u>	PROGRAM ONE PROFESSIONAL BUILDING SERVICES Window Cleaning: June 2019	07/31/2019	1,616.89	Payable Count: (1) 1,616.89
Vendor: <u>2212</u> <u>INV0003787</u>	Robert McAvoy Moraine Valley Class Reimb	07/25/2019	619.70	Payable Count: (1) 619.70

Board Open Payable Report

As Of 08/06/2019

Payable Number	Description	Post Date	Payable Amount		Net Amount
Vendor: 1813 <u>FOCS147520</u>	ROESCH FORD Vehicle Repairs: M78556	07/31/2019	2,150.01	Payable Count: (1)	2,150.01 2,150.01
Vendor: 1950 <u>2942-12</u>	RORY GROUP, LLC. CONSULTING FEE: August 2019	08/06/2019	1,500.00	Payable Count: (1)	1,500.00 1,500.00
Vendor: 1777 <u>767484</u>	SCHNEIDER ELECTRIC BUILDINGS AMERICA, INC Security Camera Service	07/31/2019	2,373.12	Payable Count: (1)	2,373.12 2,373.12
Vendor: 1805 <u>1365118</u>	TANKNOLOGY INC. Retest of underground diesel tank	07/30/2019	413.50	Payable Count: (1)	413.50 413.50
Vendor: 2029 <u>0000277317</u>	TREE TOWNS IMAGING & COLOR GRAPHICS Document Scanning	07/30/2019	93.60	Payable Count: (1)	93.60 93.60
Vendor: 1080 <u>025-266639</u>	TYLER TECHNOLOGIES, INC Maintenance: 9/1/19-8/31/20	07/30/2019	3,308.52	Payable Count: (1)	3,308.52 3,308.52
Vendor: 1427 <u>154396-11</u> <u>154562-07</u> <u>158466-00</u> <u>158468-00</u> <u>158469-00</u> <u>158856-00</u> <u>159269-00</u> <u>160497-00</u> <u>160452-00</u>	VILLA PARK ELECTRICAL SUPPLY CO., INC. Uniforms Uniforms Uniforms Uniforms Uniforms Uniforms Uniforms Weatherproof Switch Covers for ROV's LED Bulbs	07/31/2019 07/31/2019 07/31/2019 07/31/2019 07/31/2019 07/31/2019 07/31/2019 07/31/2019 08/06/2019	52.95 52.95 38.00 84.00 190.00 79.95 45.00 910.00 283.50	Payable Count: (9)	1,736.35 52.95 52.95 38.00 84.00 190.00 79.95 45.00 910.00 283.50
Vendor: 1323 <u>85630-20</u>	WATERISAC Annual Membership Dues	07/25/2019	3,149.00	Payable Count: (1)	3,149.00 3,149.00
Vendor: 2096 <u>INV0003815</u>	William A. Fates Service as Treasurer: August 2019	08/06/2019	1,666.67	Payable Count: (1)	1,666.67 1,666.67
Payable Account 01-211000				Payable Count: (37)	Total: 11,158,828.80

Payable Account Summary

Account	Count	Amount
01-211000 - ACCOUNTS PAYABLE	37	11,158,828.80
Report Total:	<u>37</u>	<u>11,158,828.80</u>

Payable Fund Summary

Fund	Count	Amount
01 - WATER FUND	37	11,158,828.80
Report Total:	<u>37</u>	<u>11,158,828.80</u>

DUPAGE WATER COMMISSION
 ITEMS TO BE PAID BY 9-19-19
 Board Meeting Date: August 15, 2019

Estimate Amount	Description	Check Number	Payment Date	Payment Amount
55,000.00	Blue Cross Blue Shield - Health Insurance			
6,000.00	Euclid Managers - Dental Insurance			
10,000.00	Illinois Public Risk Fund - Workers Comp.			
200.00	Envision Health Care - Administration Fees			
300.00	Healthiest You			
150.00	NCPERS - IMRF			
20,000.00	ComEd - Utility Charges			
300,000.00	Constellation (Exelon Energy) - Utility Charges			
180,000.00	City of Chicago - Lexington. Electric			
35,000.00	City of Chicago - Lexington Labor Costs			
35,000.00	City of Chicago - Repairs & Maintenance			
2,000.00	City of Naperville -Meter Station Electric Bills			
15,000.00	Nicor - Gas			
350.00	Comcast - Internet Service			
3,000.00	AT & T - Telephone Charges			
3,000.00	AT & T - Scada Backhaul Network/IP Flex			
1,000.00	Fed - Ex - Postage/Delivery			
5,000.00	Procurement Card Charges			
200.00	Anderson - Pest Control			
400.00	Republic Services - Disposal Services			
200.00	Elecsys - Cell Data Services			
1,500.00	Konica Minolta - Copy and Lease Charges			
625.00	Pitney Bowes - Postage			
8,000.00	Grainger - Supplies for Operations			
2,500.00	Verizon - Wireless Service			
300.00	Verizon Connect - Diagnostics			
50.00	City of Aurora - Microbial Analysis			
50.00	Bridgepoint - Hosting Services			
1,700.00	William Fates - Treasurer			
5,000.00	Baker Tilly			
15,000.00	Schirott, Luetkehans & Garner, LLC			
1,500.00	Rory Group			
7,000.00	IT Savvy - Network Support			
200.00	Edward Coughlin/Ken Lafin - Security			
600.00	Red Wing - Uniforms			
500.00	Elmhurst Standard Plaza - Vehicle Maintenance			
200.00	Sooper Lube - Vehicle Maintenance			
500.00	Storino Ramello & Durkin			
500.00	Local 399 Training courses			
7,000.00	Altorfer Power Systems - Repair Transfer Switch			
100.00	Aramark - Supplies			
7,000.00	Beary - Replacement/Maintenance of Vegetation			

DUPAGE WATER COMMISSION
ITEMS TO BE PAID BY 9-19-19
Board Meeting Date: August 15, 2019

1,000.00 Beary - Tanksite Landscaping
1,100.00 DLT Solutions - 1 year AutoCAD Renewal
500.00 Five Star Safety - Replacement Bags and Winches
300.00 Fluke Electronics - Fluke Calibration
68,000.00 Industrial Electric - Power Breakers and Transformer
13,000.00 Insight Public Sector - Replacement Desktop Computers
3,000.00 ITsavvy - Migrate File Server Data
600.00 Kara Company - Julie Marking Paint
900.00 LogMein - Annual Remote Access Renewal
1,200.00 Meccon - Reinstall of HLP Labor Rate Increase
100.00 Newark - Replacement Cooling Fans
800.00 NIU - OSHA 2264 PRCSE Training for Sanchez
500.00 Office Depot- Office Supplies
900.00 Program One - Window Cleaning
19,000.00 Pinnacle Stone Restoration - Refinishing of Terazzo
250.00 Redwing - Safety Shoes - Leanos
250.00 Redwing - Safety Shoes - Weed
400.00 Staples - Office Supplies
100.00 Sir Speedy - Business Cards
900.00 Schneider Electric - Gate 2 Transponders
2,100.00 Schneider Electric - HVAC BAS Server Upgrade
400.00 Specialty Mat Service
500.00 Transcat - Annual Cal and Data
5,000.00 Oak Security Group
4,600.00 AECOM - Electrical Safety Studies
8,500.00 Greeley and Hansen - Bartlett Meter Station
18,000.00 CDMSmith - DPPS Improvements
7,500.00 Knight E/A - DPPS HVAC Improvements
4,500.00 Strand Assoc. - Tanksite Improvements
45,000.00 Greeley and Hansen - DPPS Disinfection Facilities

940,525.00



DuPage Water Commission

MEMORANDUM

TO: Chairman Zay and Commissioners

FROM: John F. Spatz
General Manager

DATE: August 8, 2019

SUBJECT: May and June 2019 Invoices

I reviewed the Schirott, Luetkehans & Garner LLC May and June 2019 invoices for services rendered during the period May 1, 2019 – June 30, 2019 and recommend it for approval. This invoice should be placed on the August 15, 2019 Commission meeting accounts payable.

May and June 2019

Schirott, Luetkehans & Garner

May 2019

<u>CATEGORY</u>	<u>FEES</u>	<u>HOURS BILLED</u>	<u>AVERAGE HOURLY RATE</u>	<u>ATTORNEYS & PARALEGALS EMPLOYED</u>	<u>MAJOR ACTIVITIES</u>
General	\$5,300.00	26.5	\$200.00	Luetkehans (12.30 @ \$200/hr.) Garner (0.00 @ \$200/hr.) Armstrong (14.20 @ \$200/hr.)	various (meetings, review agreements, correspondence and contracts)
Misc:	\$42.49				
Total:	\$5,342.49	26.5	\$200.00		

June 2019

<u>CATEGORY</u>	<u>FEES</u>	<u>HOURS BILLED</u>	<u>AVERAGE HOURLY RATE</u>	<u>ATTORNEYS & PARALEGALS EMPLOYED</u>	<u>MAJOR ACTIVITIES</u>
General	\$2,780.00	13.9	\$200.00	Luetkehans (6.70 @ \$200/hr.) Garner (0.00 @ \$200/hr.) Armstrong (7.20 @ \$200/hr.)	various (meetings, review agreements, correspondence, contracts attend the June Board Meeting)
Misc:	\$54.05				
Total:	\$2,834.05	13.9	\$200.00		



DuPage Water Commission

MEMORANDUM

TO: Chairman Zay and Commissioners

FROM: John F. Spatz
General Manager *JF*

DATE: July 11, 2019

SUBJECT: May and June 2019 Invoices

I reviewed the Storino Ramello & Durkin May and June 2019 invoices for services rendered during the period May 1, 2019 – June 30, 2019 and recommend it for approval. This invoice should be placed on the August 15, 2019, Commission meeting accounts payable.

May and June 2019
 Storino Ramello & Durkin

May 2019

<u>CATEGORY</u>	<u>FEES</u>	<u>TOTAL HOURS BILLED</u>	<u>AVERAGE HOURLY RATE</u>	<u>ATTORNEYS & PARALEGALS EMPLOYED</u>	<u>MAJOR ACTIVITIES</u>
M. Durkin	\$55.00	0.25	\$220.00	M. Durkin (.55 @ \$220/hr.)	various items relating to Collective Bargaining Unit Local Union 399
A. Durkin	\$0.00	0.00	\$200.00	A. Durkin (0.00 @ \$200/hr.)	
M. Wolf	\$0.00	0.00	\$200.00	M. Wolf (0.00 @ \$200/hr.)	
	<u>\$55.00</u>	<u>0.25</u>			

June 2019

<u>CATEGORY</u>	<u>FEES</u>	<u>TOTAL HOURS BILLED</u>	<u>AVERAGE HOURLY RATE</u>	<u>ATTORNEYS & PARALEGALS EMPLOYED</u>	<u>MAJOR ACTIVITIES</u>
M. Durkin	\$72.60	0.33	\$220.00	M. Durkin (.33 @ \$220/hr.)	various items relating to Collective Bargaining Unit Local Union 399
A. Durkin	\$0.00	0.00	\$200.00	A. Durkin (0.00 @ \$200/hr.)	
M. Wolf	\$0.00	0.00	\$200.00	M. Wolf (0.00 @ \$200/hr.)	
	<u>\$72.60</u>	<u>0.33</u>			